

# SITE PLAN SET AT 25 HAVEN STREET (PROPOSED MOSQUE) Reading, MA

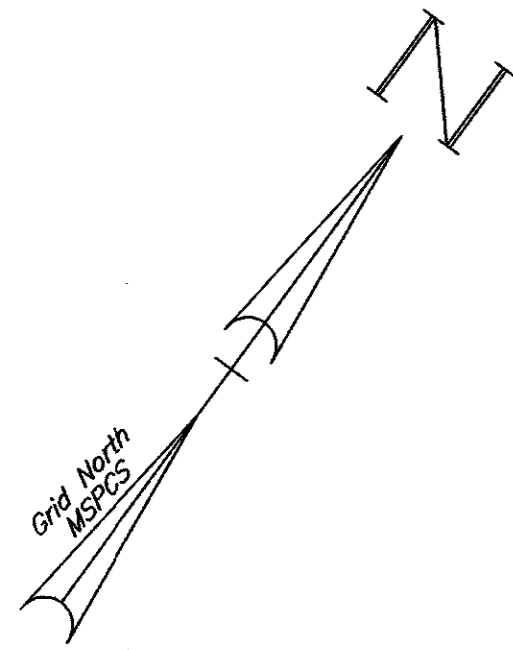

**Vicinity Map**  
Scale: 1"=200'±

**RECORD OWNER:**  
25 HAVEN STREET, LLC  
25 HAVEN STREET, READING, MASSACHUSETTS  
-ASSESSORS MAP 16 LOT 309  
-BOOK 1557 PAGE 74  
-LOT B ON LCC 6084B

**PLAN REFERENCES:**  
- LCC 6084B  
- LCC 19824A  
- PLAN 221 OF 1956

**NOTES:**

1. THIS PLAN IS BASED ON AN ACTUAL ON-THE-GROUND FIELD SURVEY CONDUCTED BY HAYES ENGINEERING, INC. ON MARCH 4, 2022.
2. THE ELEVATIONS DEPICTED HEREON ARE BASED ON THE NORTH AMERICAN VERTICAL DATUM OF 1988 (NAVD 88) BASED UPON MACORS REAL-TIME NETWORK NAD 83 (2011) (EPOCH 2010.00) DATUM USING GEOID 12B FOR ORTHOMETRIC HEIGHTS.
3. THIS PROPERTY DOES NOT LIES WITHIN A FLOOD HAZARD AREA (ZONE A OR V) AS SHOWN ON FLOOD INSURANCE RATE MAP NUMBER 25017C0313E; EFFECTIVE DATE: 06/04/2010

SHEET INDEX	
PLAN TITLE	
INDEX	C1
SITE PLAN	C2
DETAIL SHEET	C3

Prepared For:  
NAFIS Boston Learning Center  
Attn: Br. Lajal C  
8 Henshaw Street  
Woburn, MA 01801

Prepared By:

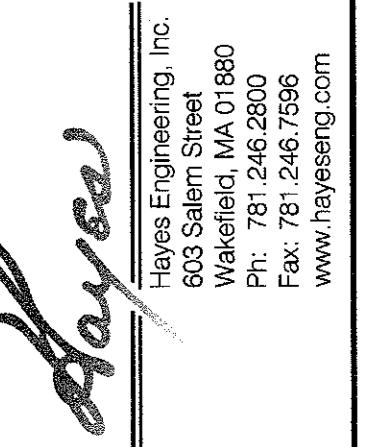

Design By: JG  
Drawn By: JG  
Checked By: PJO  
Project File: REA-0419  
Comp. No: REA175  
 Issued For Permit  
 Issued For Review  
 Issued For Bid  
 Issued For Construction  
 Not For Construction

No.	Revision	Date
10		
9		
8		
7		
6		
5		
4		
3		
2		
1		

Scale: 1"=10'  
0' 5' 10' 20'  
Date: May 25, 2023

Drawing Title:

INDEX PLAN  
25 HAVEN STREET  
PROPOSED MOSQUE  
READING, MASS.

READING COMMUNITY PLANNING AND  
DEVELOPMENT COMMISSION

\_\_\_\_\_  
\_\_\_\_\_  
\_\_\_\_\_  
\_\_\_\_\_  
DATE: \_\_\_\_\_

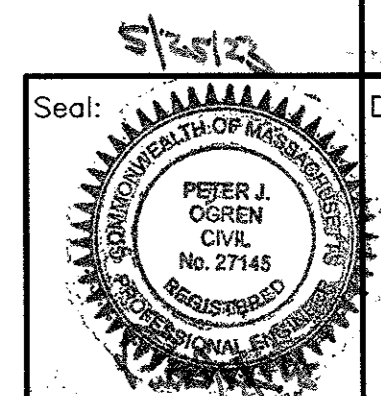

Drawing No.:

C1

SOIL LOGS									
DEPTH (ft)	SOIL HORIZON/LAYER	SOIL MATRIX: COLOR-MOIST (MUNSELL)	REDOXIMORPHIC FEATURES (MOTTLES)	SOIL TEXTURE (USDA)	COARSE FRAGMENTS % BY VOLUME	SOIL STRUCTURE	SOIL CONSISTENCE (MOIST)		
DEPTH	COLOR	PERCENT		GRAVEL	COBBLES & STONES				
DEEP HOLE NUMBER: TP-1 ELEVATION=105.1'									
00'-36"	HTM			sl	0	0/0	gr	mfr	
36'-41"	Ab	10YR 8		ls	0	0/0	m	mfr	
41'-47"	Bhb	10YR 5/6	84"	vp	30	20/0	sq	mfr	
47'-180"	C	10YR 4/6		vp	30	20/0	sq	mfr	
NO REFUSAL; STATIC WATER 92" DOWN; WEeping 92" DOWN									
ESTIMATED SEASONAL HIGH GROUNDWATER TABLE DOWN 84" AT ELEVATION = 98.1'									
DEEP HOLE NUMBER: TP-2 ELEVATION=106.5'									
00'-72"	HTM			sl	0	0/0	gr	mfr	
72'-188"	C	10YR 1	72"	vp	30	20/10	sq	mfr	
NO REFUSAL; STATIC WATER 95" DOWN; WEeping 95" DOWN									
ESTIMATED SEASONAL HIGH GROUNDWATER TABLE DOWN 95" AT ELEVATION = 98.5'									

ZONING TABLE		
ZONE BUS-B/DSGD OVERLAY		
DIMENSIONAL CONTROLS	EXISTING	PROPOSED
FRONT YARD SETBACK	0	0
SIDE YARD SETBACK	1.0	1.0
REAR YARD SETBACK	0	0
FRONTAGE	186.79	186.79
LOT AREA	18,935±SF	18,935±SF
LOT COVERAGE (bldgs.)	42%	42%
# PARKING SPACES	18	26

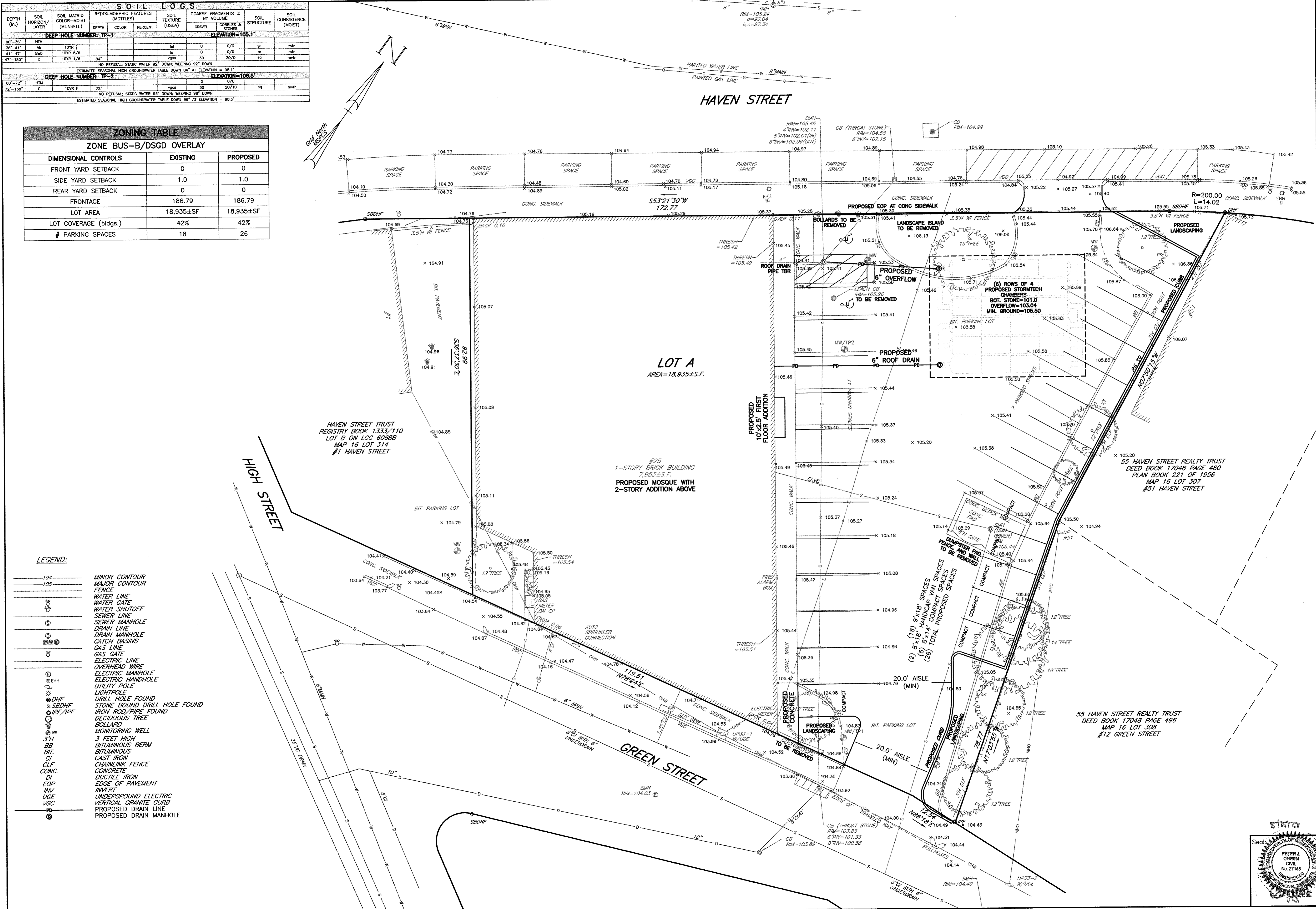

Prepared For:  
 NAFIS Boston Learning Center  
 Attn: Br. Lalal C  
 8 Henshaw Street  
 Suite F  
 Woburn, MA 01801

Prepared By:  
 Hayes Engineering, Inc.  
 Hayes Engineering, Inc.  
 Woburn, MA 01880  
 P: 781.246.2800  
 F: 781.246.7596  
 www.hayeseng.com

Design By: JG  
 Drawn By: JG  
 Checked By: PJO  
 Project File: REA-0419  
 Comp. No: REA175  
 Issued For Permit  
 Issued For Review  
 Issued For Bid  
 Issued For Construction  
 Not For Construction

No.	Revision	Date
10		
9		
8		
7		
6		
5		
4		
3		
2		
1		

Scale: 1"=10'  
 0' 5' 10' 20'  
 Date: May 25, 2023

Drawing Title:  
 SITE PLAN  
 25 HAVEN STREET  
 PROPOSED MOSQUE  
 READING, MASS.

Drawing No.:  
 C2  
 SHEET 2 OF 3

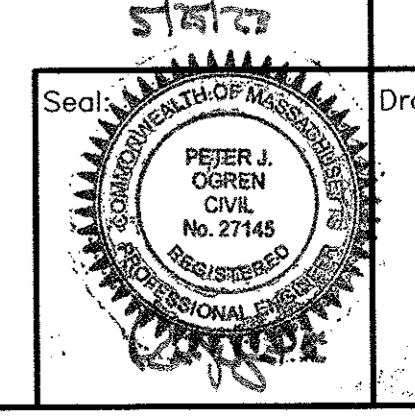

N:\REA175\SP\_25HAVEN\_L3.dwg, 5/25/2023 8:44:50 AM, 36



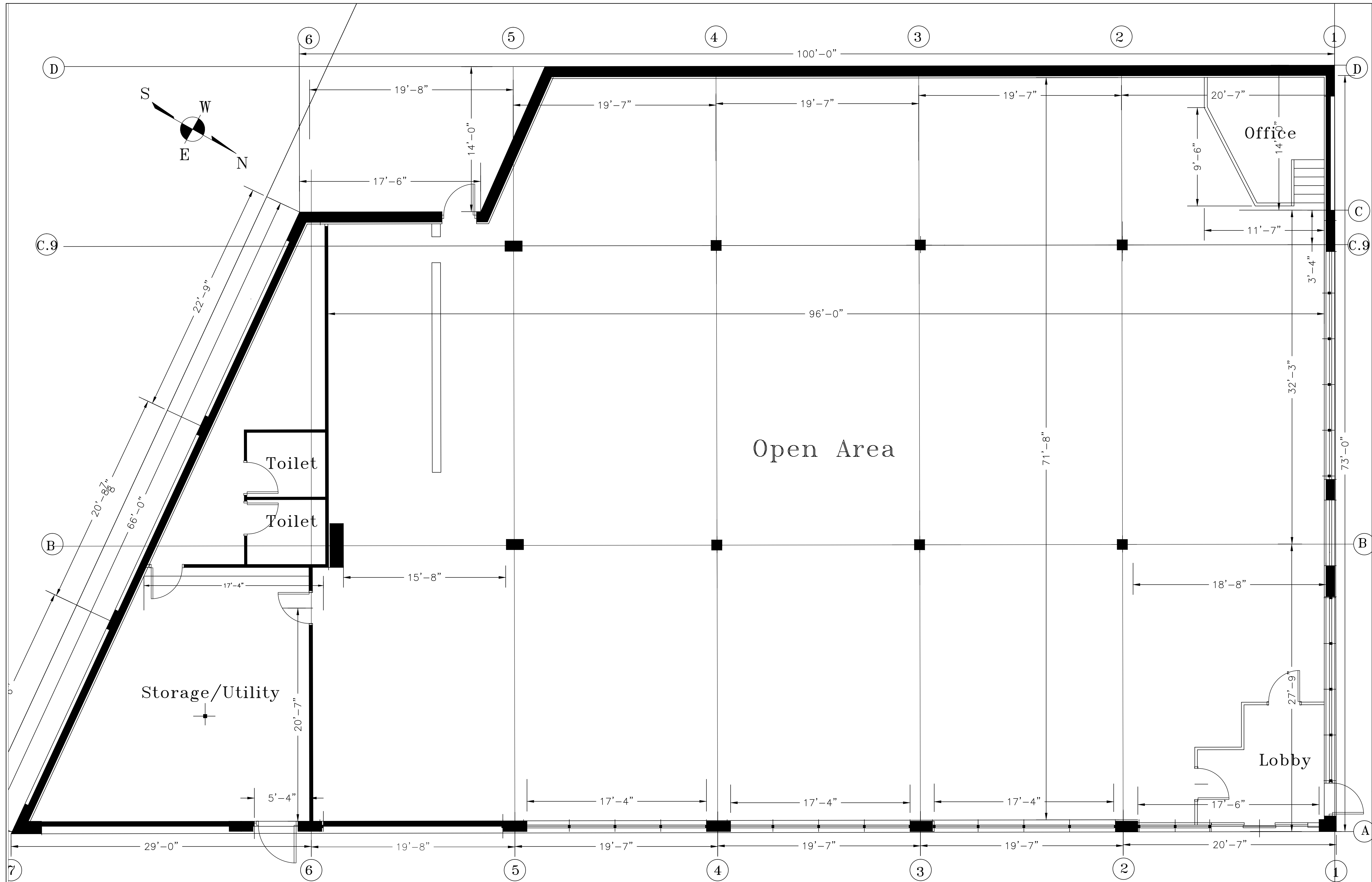

Existing 1st Floor Plan

ARCHITECT:  
 FAROUK F. YOUSSEF, AIA  
 53 EDGEWATER RD  
 HULL, MA 02045  
 TEL (617) 794-7611  
 EMAIL: farouk.youssef@gmail.com

DWG. TITLE:  
 EXISTING 1st. FLOOR PLAN

SCALE:  
 1/4" = 1'-0"  
 DATE:  
 May 31, 2023

CLIENT/PROJECT:  
 READING MOSQUE  
 North American Foundation of  
 Islamic Services (N.A.F.I.S)  
 25 Haven St. READING, MA 01867

DRAWING:  
 A-3

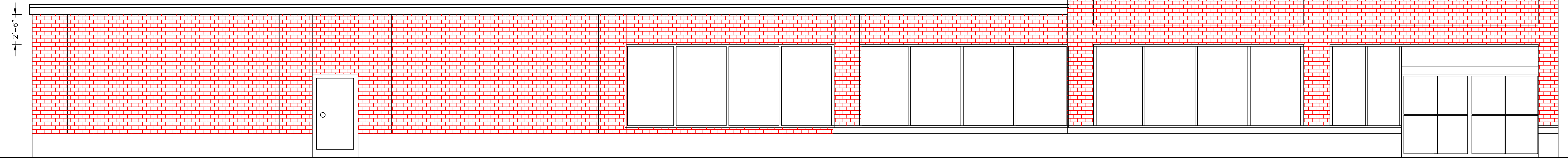

East Elevation

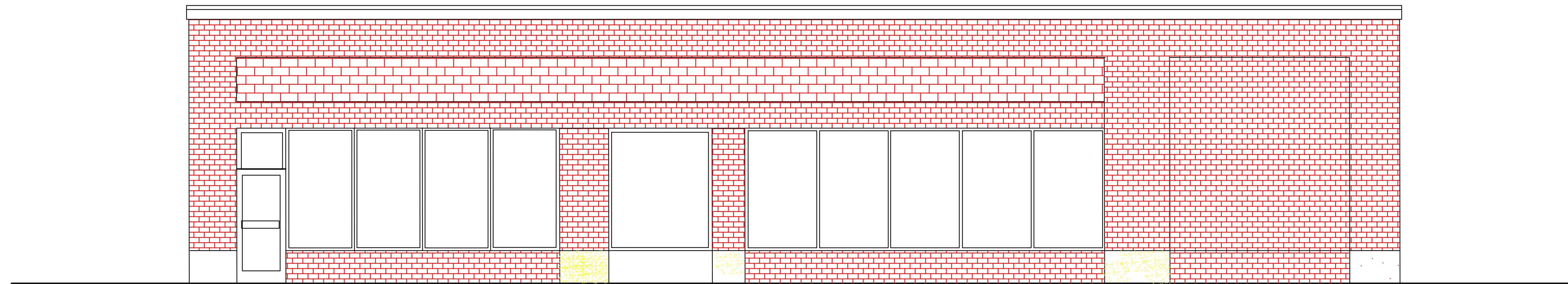

North Elevation

DRAWING:

A-4

CLIENT/PROJECT:

**READING MOSQUE**  
 North American Foundation of  
 Islamic Services (N.A.F.I.S)  
 25 Haven St. READING, MA 01867

DWG. TITLE:

**Existing East\_North Elevations**

ARCHITECT:

**FAROUK F. YOUSSEF, AIA**  
 53 EDGEWATER RD  
 HULL, MA 02045  
 TEL (617) 794-7611  
 EMAIL: farouk.youssef@gmail.com

SCALE: 1/4" = 1'-0"

DATE: May 31, 2023

REVISIONS:

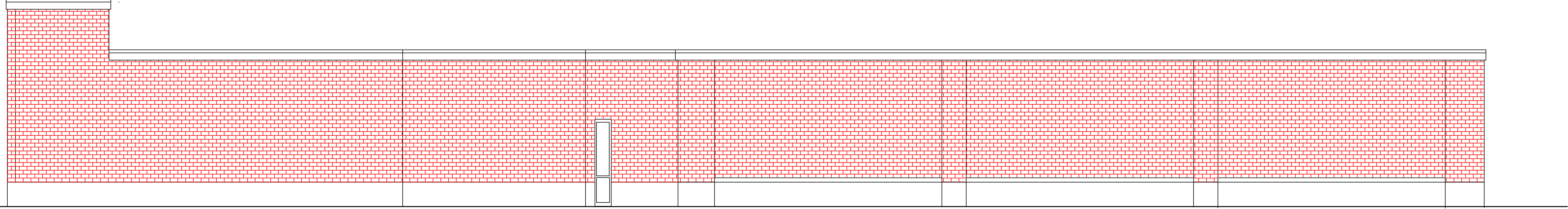

South Elevation

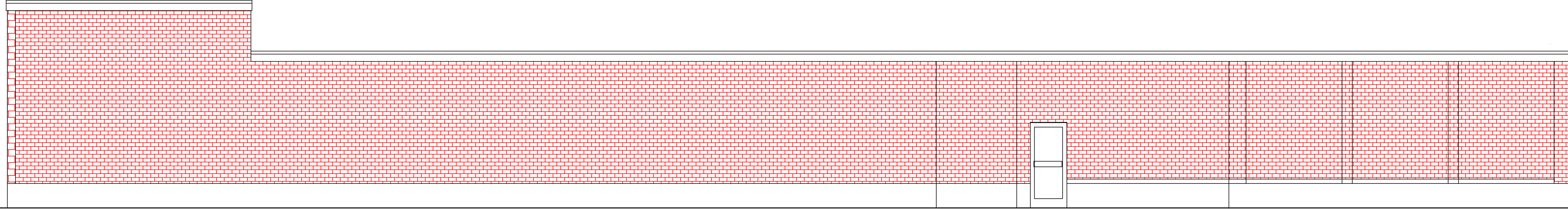

West Elevation

DRAWING:

A-5

CLIENT/PROJECT:

**READING MOSQUE**  
 North American Foundation of  
 Islamic Services (N.A.F.I.S)  
 25 Haven St. READING, MA 01867

DWG. TITLE:

**Existing West\_South Elevations**

ARCHITECT:

**FAROUK F. YOUSSEF, AIA**  
 53 EDGEWATER RD  
 HULL, MA 02045  
 TEL (617) 794-7611  
 EMAIL: farouk.youssef@gmail.com

SCALE: 1/4" = 1'-0"

DATE: May 31, 2023

REVISIONS:

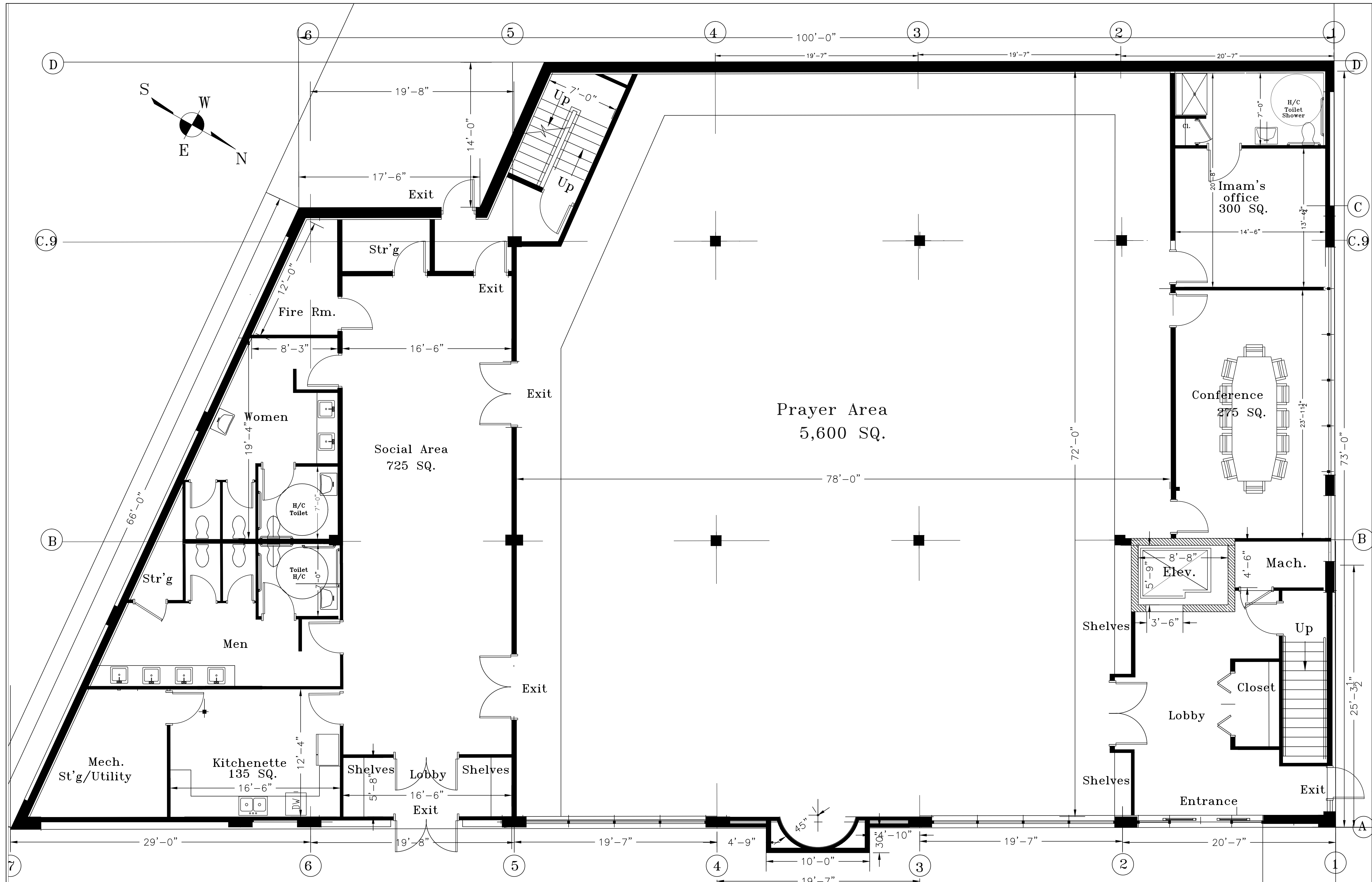

1st Floor Mosque Plan

ARCHITECT: <b>FAROUK F. YOUSSEF, AIA</b> 53 EDGEWATER RD HULL, MA 02045 TEL: (617) 794-7611 EMAIL: farouk.youssef@gmail.com	
DWG. TITLE: <b>PROPOSED 1st FLOOR PLAN_MOSQUE</b>	
CLIENT/PROJECT: <b>READING MOSQUE</b> North American Foundation of Islamic Services (N.A.F.I.S) 25 Haven St. READING, MA 01867	REVISIONS: SCALE: 1/4" = 1'-0" DATE: May 31, 2023
DRAWING: <b>A-6</b>	

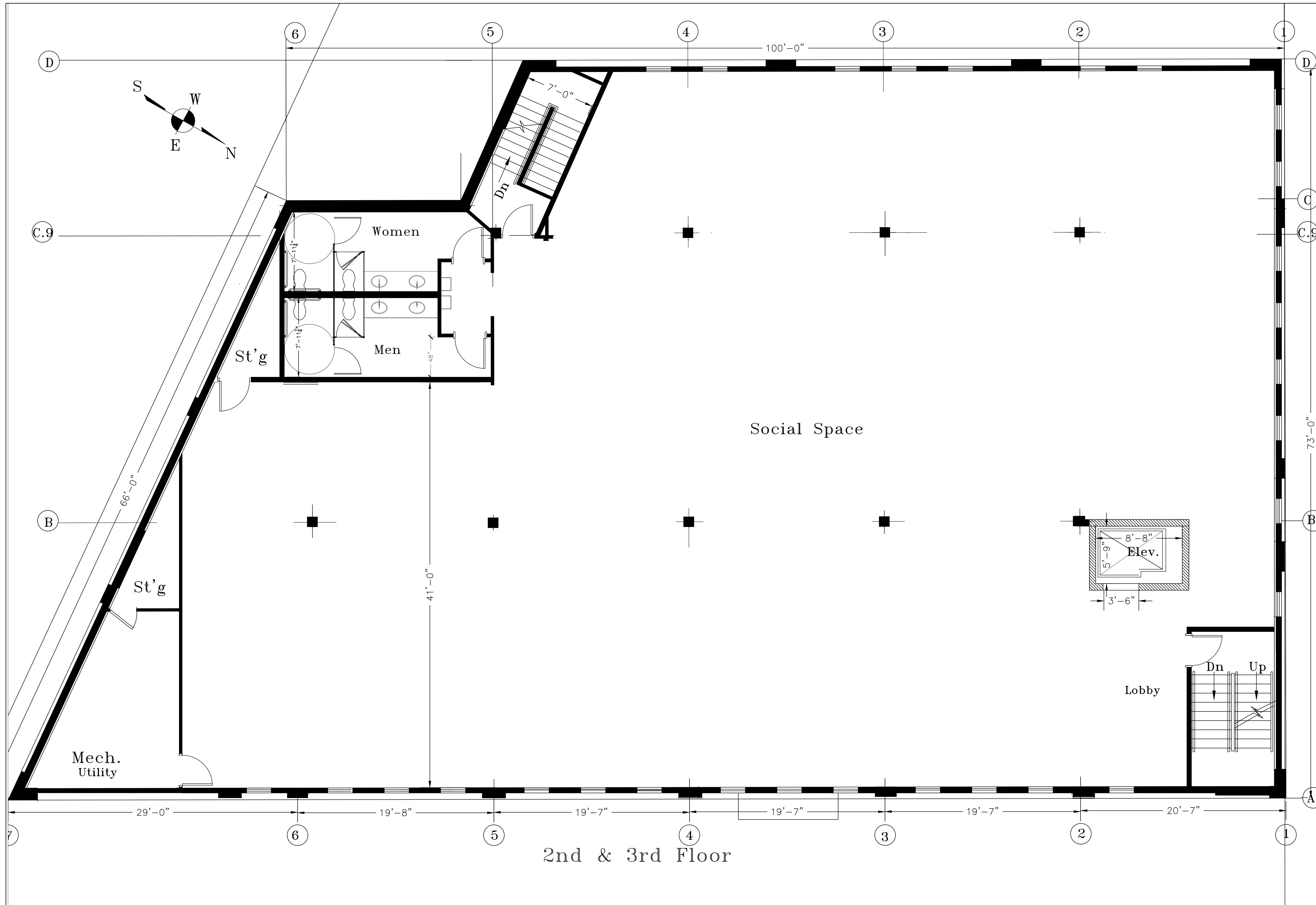

2nd & 3rd Floor

ARCHITECT:  
 FAROUK F. YOUSSEF, AIA  
 53 EDGEWATER RD  
 HULL, MA 02045  
 TEL: (617) 794-7611  
 EMAIL: farouk.youssef@gmail.com

DWG. TITLE:  
**PROPOSED TYP. 2nd & 3rd FLOOR PLAN**

SCALE:  
 1/4" = 1'-0"

DATE:  
 May 31, 2023

REVISIONS:

CLIENT/PROJECT:  
**READING MOSQUE**  
 North American Foundation of  
 Islamic Services (N.A.F.I.S)  
 25 Haven St. READING, MA 01867

DRAWING:  
**A-7**





Proposed East Elevation



Proposed North Elevation

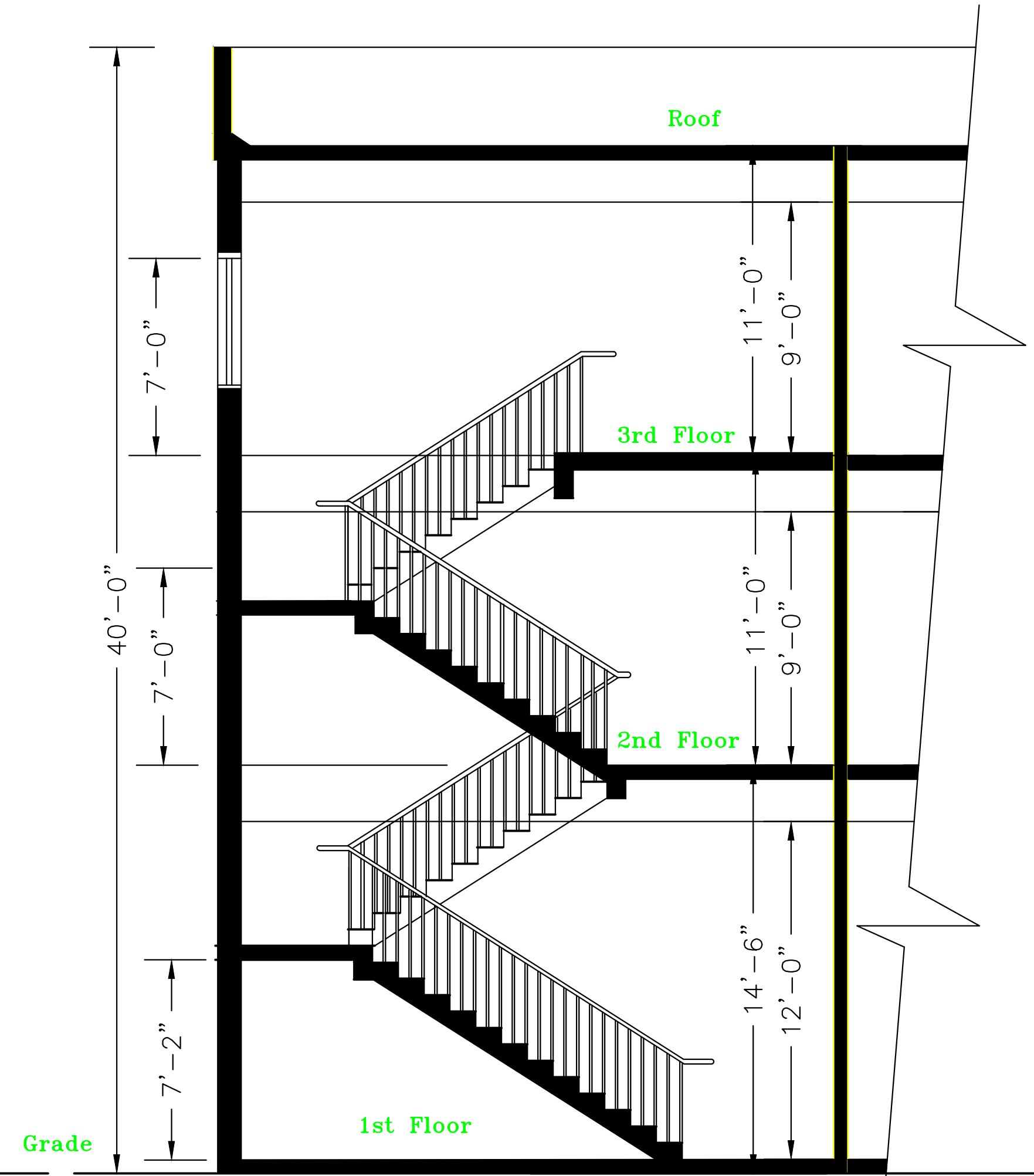

Section

ARCHITECT:  
 FAROUK F. YOUSSEF, AIA  
 53 EDGEWATER RD  
 HULL, MA 02045  
 TEL (617) 794-7611  
 EMAIL: farouk.youssef@gmail.com

DWG. TITLE: Proposed East\_North Elevations  
 SCALE: 1/4" = 1'-0"  
 DATE: May 31, 2023  
 REVISIONS:

CLIENT/PROJECT:  
 READING MOSQUE  
 North American Foundation of  
 Islamic Services (N.A.F.I.S)  
 25 Haven St. READING, MA 01867

DRAWING:  
 A-8

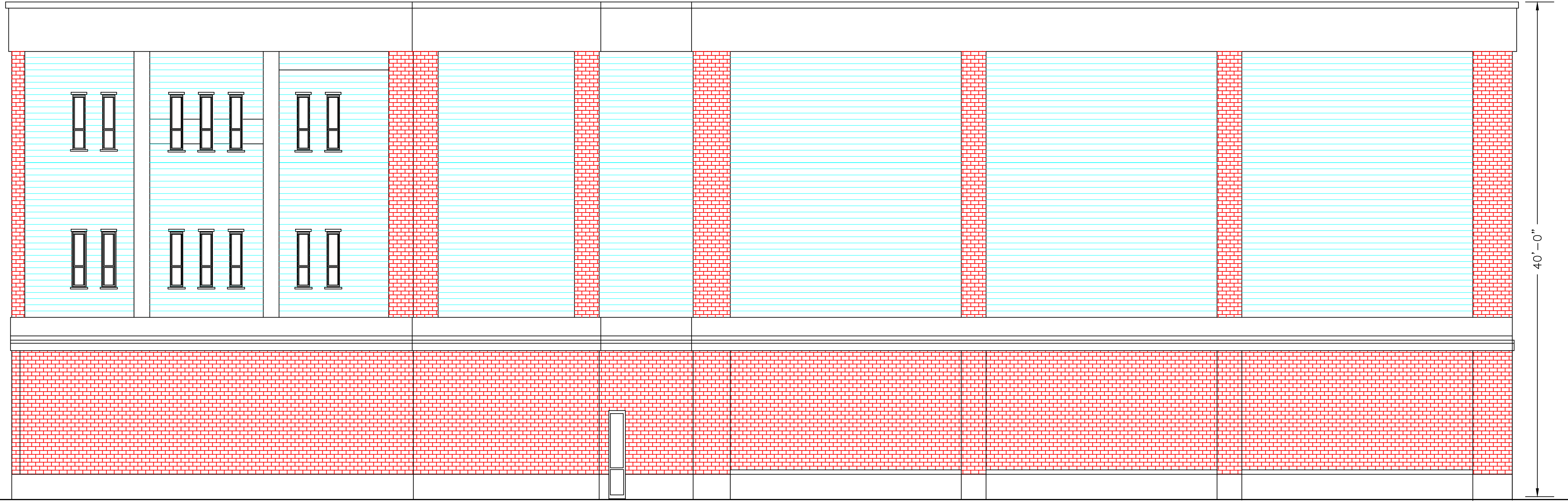

Proposed South Elevation

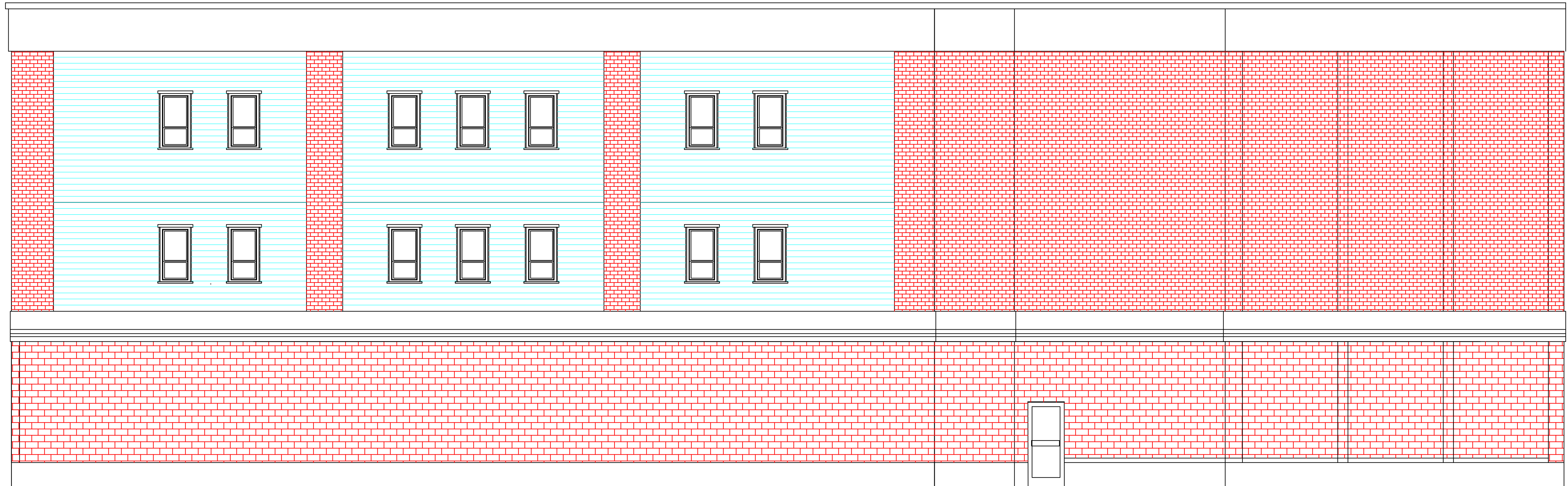

Proposed West Elevation

ARCHITECT:

FAROUK F. YOUSSEF, AIA  
53 EDGEWATER RD  
HULL, MA 02045  
TEL (617) 794-7611  
EMAIL: farouk.youssef@gmail.com

DWG. TITLE: Proposed West\_South Elevations

REVISIONS:

SCALE: 1/4" = 1'-0"

DATE: May 31, 2023

CLIENT/PROJECT:

READING MOSQUE  
North American Foundation of  
Islamic Services (N.A.F.I.S)  
25 Haven St. READING, MA 01867

DRAWING:

A-9

PRELIMINARY SUBDIVISION PLAN SET

246 WALNUT STREET

READING, MASSACHUSETTS

TAX MAP 3 LOT 9

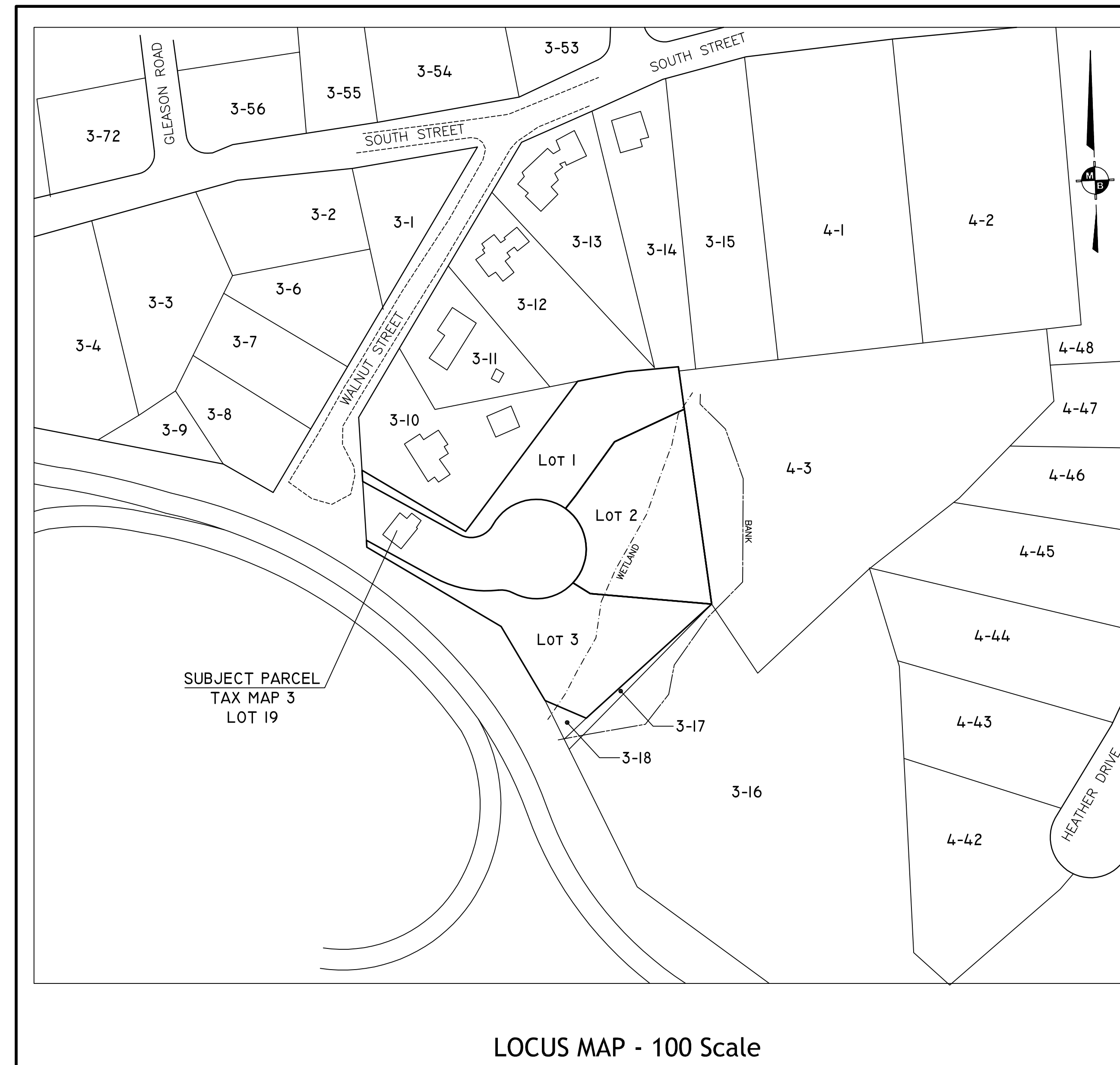

LOCUS MAP - 100 Scale

NOTES:

- PURPOSE OF PLAN** THIS PLAN IS INTENDED TO BE A PRELIMINARY PLAN PURSUANT TO M.G.L. Ch.41, Section 81T AND Section 5.0 OF THE READING SUBDIVISION REGULATIONS SHOWING 3 LOTS BEING SUBDIVIDED WITH A SMALL EXTENSION OF WALNUT STREET (TOTAL 0 2 NEW LOTS).
- TAX MAP 3 PARCEL 19**  
LOT AREA: 2.02 ACRES
- OWNER:**  
BALSAVICH STEVEN T KORTZ ERIK ETAL JTROS
- ZONING: SINGLE FAMILY 20**  
REQUIRED AREA: 20,000 S.F.  
(12,000 S.F. UPLAND)  
REQUIRED FRONTAGE: 120'  
(\*80' ON A CURVE LESS THEN 200')  
\*REDUCED FRONTAGE MUST BE 120'  
AT THE REAR OF THE FRONT SETBACK  
REQUIRED LOT WIDTH: 80'  
(MEASURED AT ALL POINTS FROM THE  
REQUIRED FRONTAGE:  
TO THE FRONT OF THE DWELLING  
SETBACKS: FRONT: 20'  
SIDE: 15'  
REAR: 20'
- PROJECT TO BE SERVICED BY MUNICIPAL WATER AND SEWER
- WAIVER WILL BE REQUESTED TO SET RIGHT-OF-WAY WIDTH TO 50'  
(SECTION 7.1.5.g.)
- WAIVER MAY BE REQUIRED FOR MAXIMUM LENGTH OF A CUL-DE-SAC  
GREATER THAN 500' (SECTION 7.1.1.g. WIDTH AND GRADE OF WAYS)
- WETLAND SURVEY PERFORMED BY BASBANES AND ASSOC.  
IN JANUARY OF 2023 AND SURVEYED BY MEISNER BREM CORPORATION
- THE PROJECT WILL REQUIRE AN ORDER OF CONDITIONS FROM THE READING CONSERVATION COMMISSION FOR WORK WITHIN THE RIVERFRONT AREA. AS PART OF THE NOTICE OF INTENT APPLICATION THE APPLICANT WILL BE REQUIRED TO PERFORM AN ALTERNATIVE ANALYSIS PURSUANT TO 310 CMR 10.58(4)(c) FOR WORK IN THE OUTER RIPARIAN ZONE OF THE RIVER FRONT AREA.

PREPARED FOR:  
STELLA CONSTRUCTION  
25 Everett Street  
Woburn, MA 01810

PREPARED BY:

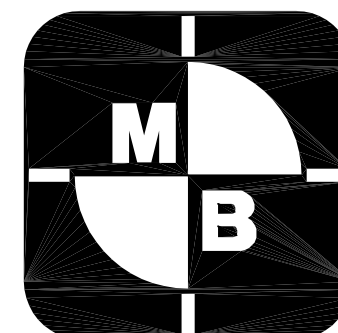

**MEISNER BREM CORPORATION**

142 LITTLETON ROAD, STE. 16, WESTFORD, MA 01886 • (978) 692-1313  
202 MAIN STREET, SALEM, NH 03079 • (603) 893-3301

- SHEET 1 PRELIMINARY SUBDIVISION PLAN - COVER  
SHEET 2 PRELIMINARY SUBDIVISION PLAN - WITH TOPOGRAPHY  
SHEET 3 PRELIMINARY SUBDIVISION PLAN - LAYOUT

© 2023 All Rights Reserved Meisner Brem Corp. REV. 1 6-14-2023 PM Per Town Comments

PRELIMINARY SUBDIVISION PLAN  
246 WALNUT STREET  
READING, MASSACHUSETTS

PREPARED FOR:  
STELLA CONSTRUCTION  
25 Everett Street  
Woburn, MA 01810  
MAY 3, 2023

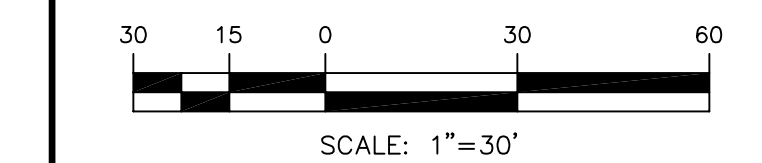

**MEISNER BREM CORPORATION**  
142 LITTLETON ROAD, STE. 16, WESTFORD, MA 01886 • (978) 692-1313  
202 MAIN STREET, SALEM, NH 03079 • (603) 893-3301

JOB NUMBER: 3110  
ACAD FILE: 3110-Stella Const. Prelim

1 OF 1

© 2023 MEISNER BREM CORPORATION  
THIS DOCUMENT AND THE WORK AND INFORMATION CONTAINED HEREIN, IS THE SOLE AND EXCLUSIVE PROPERTY OF MEISNER BREM CORPORATION, AND IS PROTECTED AS AN ORIGINAL WORK OF AUTHORSHIP UNDER THE COPYRIGHT ACT, AS SET FORTH IN TITLE 17 OF THE UNITED STATES CODE. ALL RIGHTS RESERVED. NEITHER THIS DOCUMENT NOR ANY OF THE WORK OR INFORMATION CONTAINED HEREIN, MAY BE PRINTED, REPRODUCED, PUBLISHED, COPIED, SOLD, TRANSLATED, CONVERTED, ARRANGED, ADAPTED, DELIVERED OR PERFORMED, WITHOUT THE EXPRESS WRITTEN PERMISSION OF MEISNER BREM CORPORATION.

REVISION 1 : JUNE 14, 2023

DATE OF PLAN : MAY 3, 2023

3/10

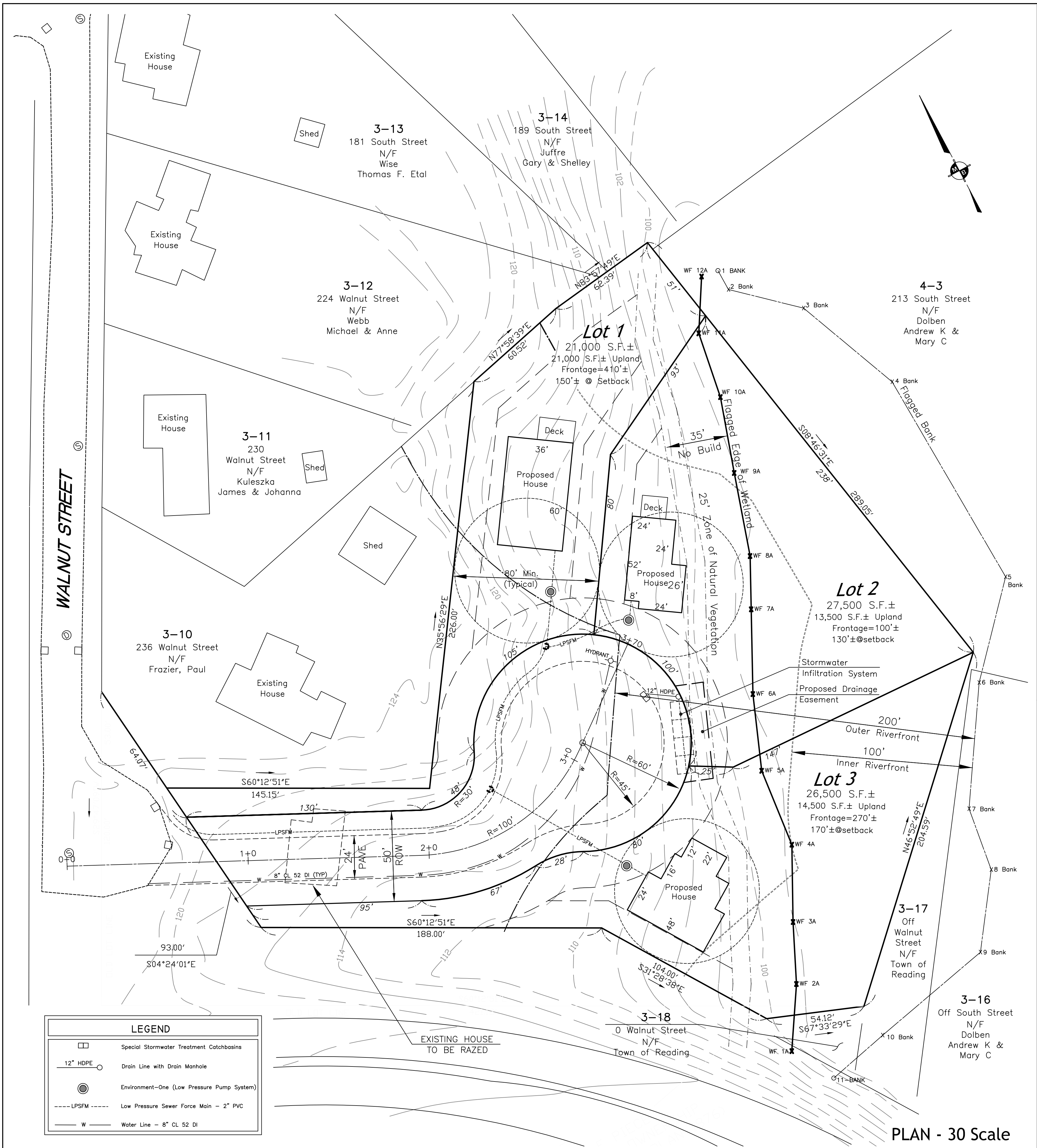

PLAN - 30 Scale



**NOTES:**

- PURPOSE OF PLAN:** THIS PLAN IS INTENDED TO BE A PRELIMINARY PLAN PURSUANT TO M.G.L. Ch.41, Section 81T AND Section 5.0 OF THE READING SUBDIVISION REGULATIONS SHOWING 3 LOTS BEING SUBDIVIDED WITH A SMALL EXTENSION OF WALNUT STREET (TOTAL 0 2 NEW LOTS).
- TAX MAP 3 PARCEL 19:** LOT AREA: 2.02 ACRES
- OWNER:** BALSAVICH STEVEN T KORTZ ERIK ETAL JTROS
- ZONING: SINGLE FAMILY 20**  
REQUIRED AREA: 20,000 S.F.  
(12,000 S.F. UPLAND)  
REQUIRED FRONTAGE: 120'  
(\*80' ON A CURVE LESS THEN 200')  
\*REDUCED FRONTAGE MUST BE 120'  
AT THE REAR OF THE FRONT SETBACK  
REQUIRED LOT WIDTH: 80'  
(MEASURED AT ALL POINTS FROM THE  
REQUIRED FRONTAGE:  
TO THE FRONT OF THE DWELLING  
SETBACKS: FRONT: 20'  
SIDE: 15'  
REAR: 20'
- PROJECT TO BE SERVICED BY MUNICIPAL WATER AND SEWER
- WAIVER WILL BE REQUESTED TO SET RIGHT-OF-WAY WIDTH TO 50' (SECTION 7.1.5.a.)
- WAIVER MAY BE REQUIRED FOR MAXIMUM LENGTH OF A CUL-DE-SAC GREATER THAN 500' (SECTION 7.1.1.a. WIDTH AND GRADE OF WAYS)
- WETLAND SURVEY PERFORMED BY BASBANES AND ASSOC. IN JANUARY OF 2023 AND SURVEYED BY MEISNER BREM CORPORATION
- THE PROJECT WILL REQUIRE AN ORDER OF CONDITIONS FROM THE READING CONSERVATION COMMISSION FOR WORK WITHIN THE RIVERFRONT AREA. AS PART OF THE NOTICE OF INTENT APPLICATION THE APPLICANT WILL BE REQUIRED TO PERFORM AN ALTERNATIVE ANALYSIS PURSUANT TO 310 CMR 10.58(4)(c) FOR WORK IN THE OUTER RIPARIAN ZONE OF THE RIVER FRONT AREA.

© 2023 All Rights Reserved  
Meisner Brem Corp. REV. 1 | 6-14-2023 | PM  
Per Town Comments

**PRELIMINARY SUBDIVISION PLAN**  
**246 WALNUT STREET**  
**READING, MASSACHUSETTS**

PREPARED FOR:  
**STELLA CONSTRUCTION**  
25 Everett Street  
Woburn, MA 01810  
MAY 3, 2023

30 15 0 30 60  
SCALE: 1"=30'

**MEISNER BREM CORPORATION**  
142 LITTLETON ROAD, STE. 16, WESTFORD, MA 01886 (978) 892-1313  
202 MAIN STREET, SALEM, NH 03079 (603) 893-3301

JOB NUMBER: 3110  
ACAD FILE: 3110-Stella Const. Prelim

2 OF 3

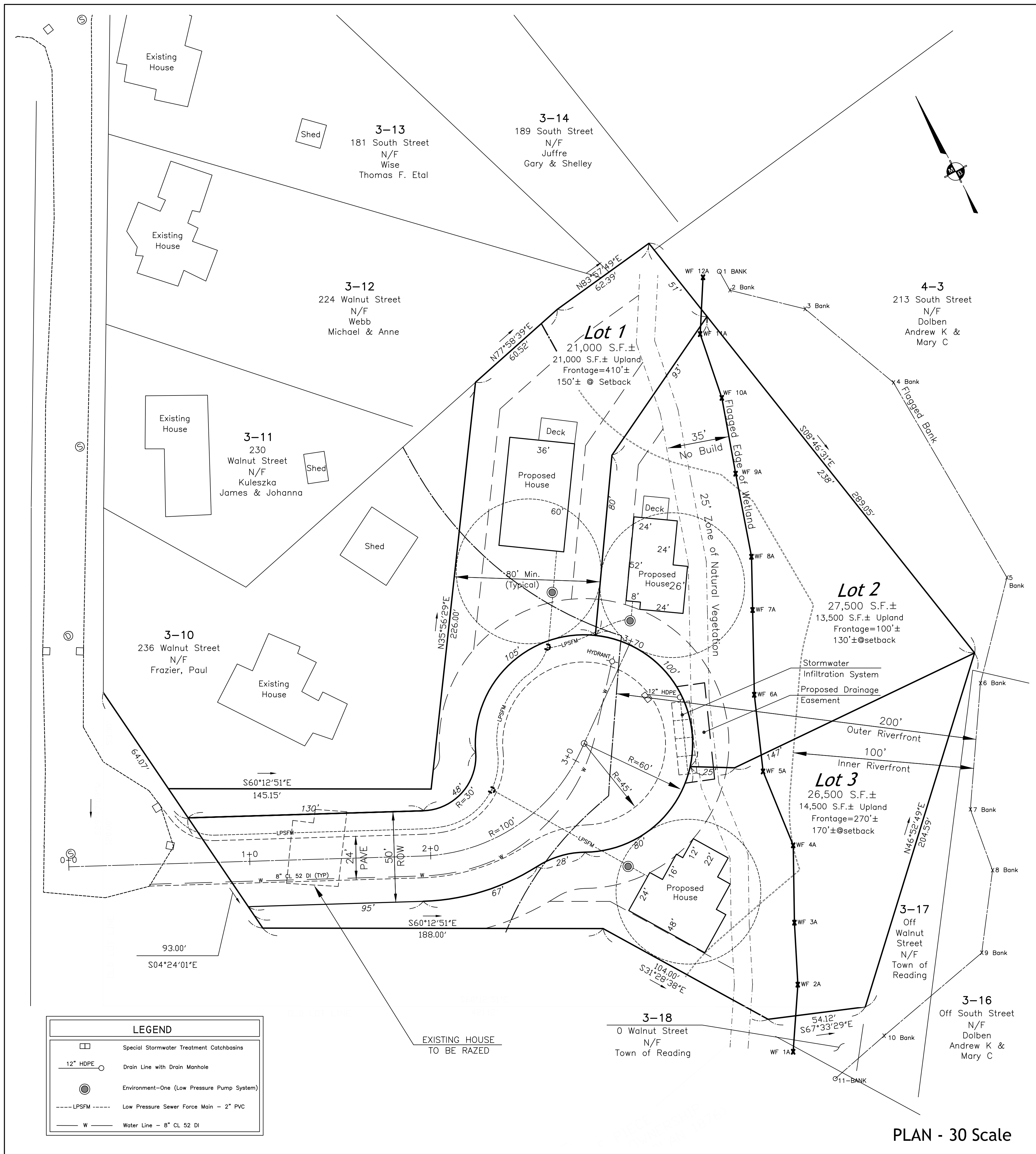

LEGEND	
	Special Stormwater Treatment Catchbasins
	12" HDPE Drain Line with Drain Manhole
	Environment-One (Low Pressure Pump System)
	LPSFM Low Pressure Sewer Force Main - 2" PVC
	W Water Line - 8" CL 52 DI

PLAN - 30 Scale

© 2023 All Rights Reserved Meisner Brem Corp.		REV. 1 6-14-2023 PM Per Town Comments
PRELIMINARY SUBDIVISION PLAN LAYOUT PLAN		
246 WALNUT STREET READING, MASSACHUSETTS		
PREPARED FOR: STELLA CONSTRUCTION 25 Everett Street Woburn, MA 01810		
MAY 3, 2023		
 SCALE: 1"=30'		
<b>MEISNER BREM CORPORATION</b>		142 LITTLETON ROAD, STE. 16, WESTFORD, MA 01886 (978) 692-1313 202 MAIN STREET, SALEM, NH 03079 (603) 893-3301
JOB NUMBER: 3110	3 OF 3	
ACAD FILE: 3110-Stella Const. Prelim		

© 2023 MEISNER BREM CORPORATION  
This document and the work and information contained herein, is the sole and exclusive property of Meisner Brem Corporation, and is protected as an original work of authorship under the Copyright Act, as set forth in Title 17 of the United States Code. All rights reserved. Neither this document, nor any of the work or information contained herein, may be printed, reproduced, published, copied, sold, transmitted, converted, arranged, adapted, delivered or performed, without the express written permission of Meisner Brem Corporation.



**MEISNER BREM CORPORATION**  
**ENGINEERS • PLANNERS • LAND SURVEYORS**

July 6, 2023

Heather Clish, Chair  
Reading Community Planning and Development Commission  
16 Lowell St,  
Reading, MA 01867

Re: 246 Walnut Street  
Preliminary Plan

Dear Ms. Clish and Members of the Reading Community Planning and Development Commission:

On behalf of our clients, Stella Construction, the applicant hereby requests CPDC to consider the following waivers from the Rules and Regulations Governing the Subdivision of Land in Reading:

Section:	Nature of Requested Waiver:
6.1.1.d.3	Traffic Study – entirety. The project is extremely small of only 2 additional lots and is just an extension of a cul-de-sac.
7.1.1	Right of way width to 50' from 60' – reasonable for utilities.
7.1.3	Traveled Way to 24' from 30' – reasonable for 3 homes in cul-de-sac
7.1.3.e	Side slope - to 2:1 from 3:1 to provide grading flexibility
7.1.5.a	Dead End Street > 500' as extension of an existing dead end improving the turn around to allow emergency vehicles to fully turn around.
7.1.7.a	Vertical Granite curb – minor extension of a street without curbing
7.2	Sidewalks (both sides) – minor extension of a street without sidewalks.

Thank you for your anticipated fair consideration.

Sincerely  
MEISNER BREM CORPORATION

Jeffrey A. Brem  
Principal Engineer

Cc: Erik Kortz, Client

# Memo

**To:** Andrew MacNichol , Community Development Director  
**From:** Ryan A. Percival, P.E., Town Engineer  
**CC:** Mary Benedetto, Senior Planner  
**Date:** July 6, 2023  
**Re:** Grandview Road Extension

---

## Materials reviewed:

- Proposed Site Plans entitled; “Major Site Plan Modification- Grandview Road Subdivision prepared by Fodera Engineering revision date June 20<sup>th</sup> 2023”
- Revision Comments, Definitive Subdivision – Grandview Road Extension; prepared by Fodera Engineering; dated June 20, 2023
- Post Drainage Report; prepared by Fodera Engineering; dated June 20, 2023

The Engineering Division has reviewed the proposed site application for the proposed project and offers the following comments:

- Engineering has completed their review and find that all comments have been satisfied.
- Additional catch basins in the road should be considered to reduce the potential of on street flooding in the cul-de-sac. If that single basin becomes clogged the street will flood.
- A Sewer Connection I/I fee is required.
- The driveway curb cuts shall meet Town of Reading standard cross sections. The proposed elevations are unclear in these areas, all driveways will be approved individually.
- All utilities shall be approved materials and installed in accordance with the Department of Public Works Standards.
- Engineering Division shall be notified 72 hours in advance to mark out Town utilities.
- All water, sewer, curb cut, street opening and Jackie’s Law excavation permits shall be obtained at the Engineering Division prior to any excavations.
- All site work shall be inspected by the Engineering Division. The Applicant/Owner’s contractor shall submit a construction schedule of proposed work. All inspections shall be scheduled 48 hours in advance.
- An approved site as-built shall be submitted to the Engineering Division within 60 days of certificate of occupancy. The as-built shall be submitted in mylar and electronic ACAD format.





**LEGEND**

- ⊕ BM # BENCHMARK
- ▣ BOUND (CONC. STONE, LAND COURT, ETC.)
- ▣ CB CATCH BASIN - SQUARE
- ⊕ CB CATCH BASIN - ROUND
- ⊙ DSK DISK (CAVT. USC&GS, LAND COURT, ETC.)
- ⊙ DH DRILL HOLE
- ⊙ DMH DRAIN MANHOLE
- ⊙ EHH ELECTRIC HANDHOLE
- ⊙ EM ELECTRIC MANHOLE
- ⊙ EM ELECTRIC METER
- ⊙ GG GAS GATE
- ⊙ GM GAS METER
- ♿ HANDICAP SYMBOL
- ⊙ GUY WIRE ANCHOR
- ⊙ FIRE HYDRANT
- ☀ LIGHT
- OHW OVERHEAD WIRE
- ⊙ MAG MAG NAIL
- ⊙ MB MAIL BOX
- ⊙ OTHER MANHOLE
- ⊙ PB PULL BOX
- ⊙ PED PEDESTRIAN SIGNAL
- ⊙ SEWER MANHOLE
- ⊙ TELEPHONE MANHOLE
- ⊙ TRANSFORMER
- ⊙ # OF PARKING SPACES
- ⊙ TS TRAFFIC SIGNAL
- ⊙ TS TRAFFIC SIGNAL MAST ARM/SPAN WIRE POLE SIGN
- ⊙ ULT# UTILITY POLE W/LIGHT
- ⊙ UPL# UTILITY POLE
- ⊙ WG WATER GATE
- ⊙ WSO WATER SHUTOFF
- CHAIN LINK FENCE
- WOOD FENCE

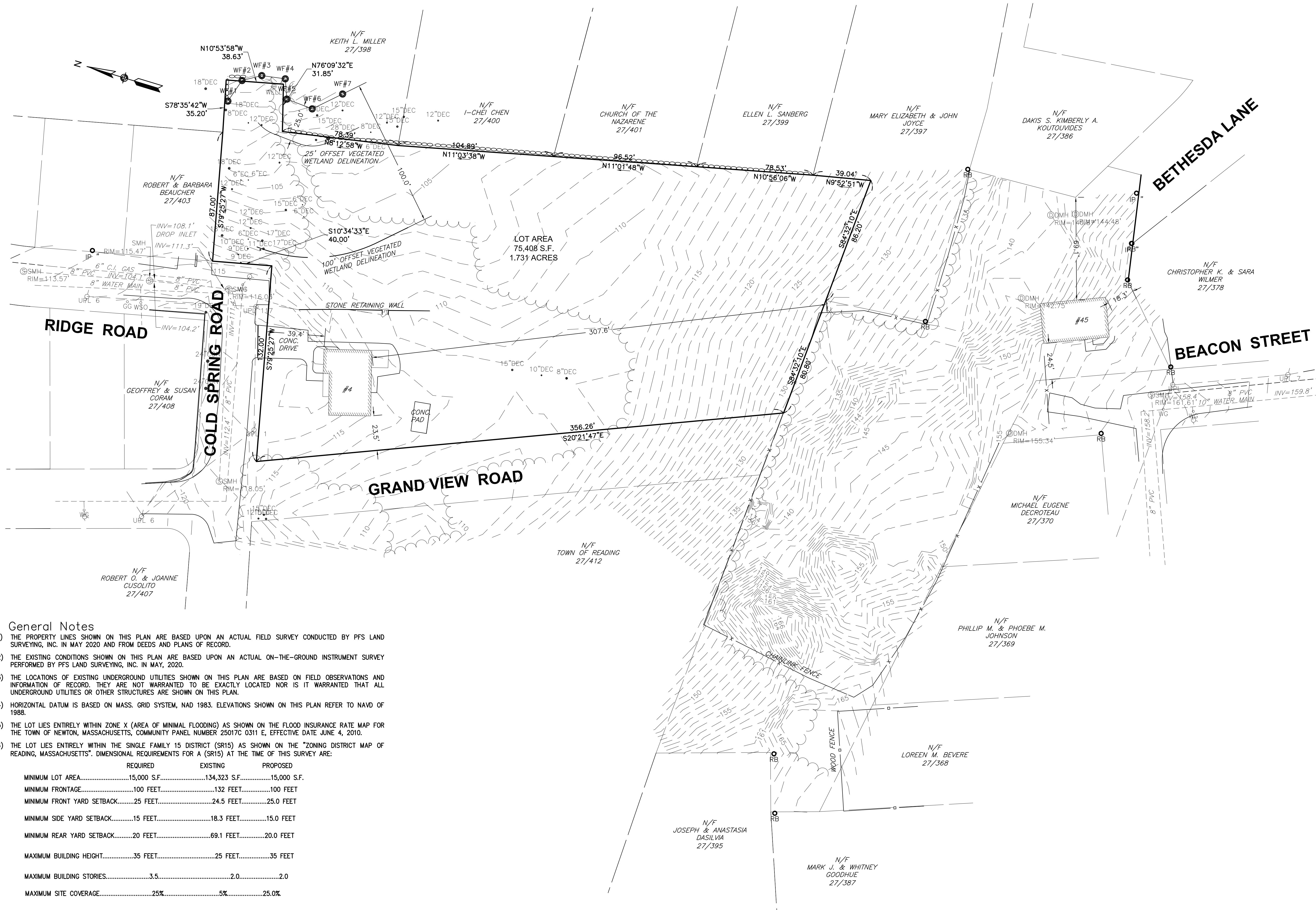

**General Notes**

- 1) THE PROPERTY LINES SHOWN ON THIS PLAN ARE BASED UPON AN ACTUAL FIELD SURVEY CONDUCTED BY PFS LAND SURVEYING, INC. IN MAY 2020 AND FROM DEEDS AND PLANS OF RECORD.
- 2) THE EXISTING CONDITIONS SHOWN ON THIS PLAN ARE BASED UPON AN ACTUAL ON-THE-GROUND INSTRUMENT SURVEY PERFORMED BY PFS LAND SURVEYING, INC. IN MAY, 2020.
- 3) THE LOCATIONS OF EXISTING UNDERGROUND UTILITIES SHOWN ON THIS PLAN ARE BASED ON FIELD OBSERVATIONS AND INFORMATION OF RECORD. THEY ARE NOT WARRANTED TO BE EXACTLY LOCATED NOR IS IT WARRANTED THAT ALL UNDERGROUND UTILITIES OR OTHER STRUCTURES ARE SHOWN ON THIS PLAN.
- 4) HORIZONTAL DATUM IS BASED ON MASS. GRID SYSTEM, NAD 1983. ELEVATIONS SHOWN ON THIS PLAN REFER TO NAVD OF 1988.
- 5) THE LOT LIES ENTIRELY WITHIN ZONE X (AREA OF MINIMAL FLOODING) AS SHOWN ON THE FLOOD INSURANCE RATE MAP FOR THE TOWN OF NEWTON, MASSACHUSETTS, COMMUNITY PANEL NUMBER 25017C 0311 E, EFFECTIVE DATE JUNE 4, 2010.
- 6) THE LOT LIES ENTIRELY WITHIN THE SINGLE FAMILY 15 DISTRICT (SR15) AS SHOWN ON THE "ZONING DISTRICT MAP OF READING, MASSACHUSETTS". DIMENSIONAL REQUIREMENTS FOR A (SR15) AT THE TIME OF THIS SURVEY ARE:
 

	REQUIRED	EXISTING	PROPOSED
MINIMUM LOT AREA.....	15,000 S.F.	134,323 S.F.	15,000 S.F.
MINIMUM FRONTAGE.....	100 FEET.....	132 FEET.....	100 FEET
MINIMUM FRONT YARD SETBACK.....	25 FEET.....	24.5 FEET.....	25.0 FEET
MINIMUM SIDE YARD SETBACK.....	15 FEET.....	18.3 FEET.....	15.0 FEET
MINIMUM REAR YARD SETBACK.....	20 FEET.....	69.1 FEET.....	20.0 FEET
MAXIMUM BUILDING HEIGHT.....	35 FEET.....	25 FEET.....	35 FEET
MAXIMUM BUILDING STORIES.....	3.5.....	2.0.....	2.0
MAXIMUM SITE COVERAGE.....	25%.....	5%.....	25.0%
- 7) THE WETLANDS SHOWN HEREON WERE FLAGGED BY LEC ENVIRONMENTAL IN JUNE 2020 AND LOCATED BY PFS LAND SURVEYING INC, IN JUNE 2020.

No.	Revision	Date	Apprv.
2	added tree locations in buffer zone	2-04-2021	BGP
1	updated well location	12-09-2020	BGP

Designed by BGP    Drawn by BGP    Checked by BGP  
 CAD checked by BGP    Approved by BGP  
 Scale 1"=30'    Date 7/8/2020

**Existing Conditions**  
 4 Cold Spring Rd  
 Reading, MA

Issued for  
 Review

Drawing Title  
**Existing Conditions**  
 Plan of Land

Drawing Number  
**SV-1**

Sheet  
 1 of 1

Project Number

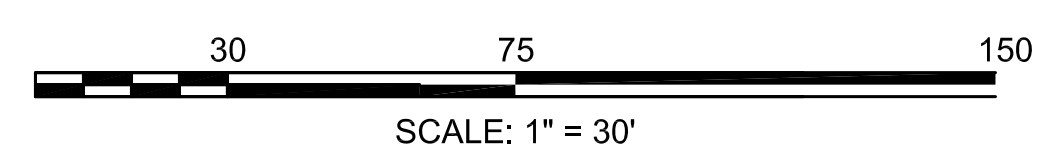



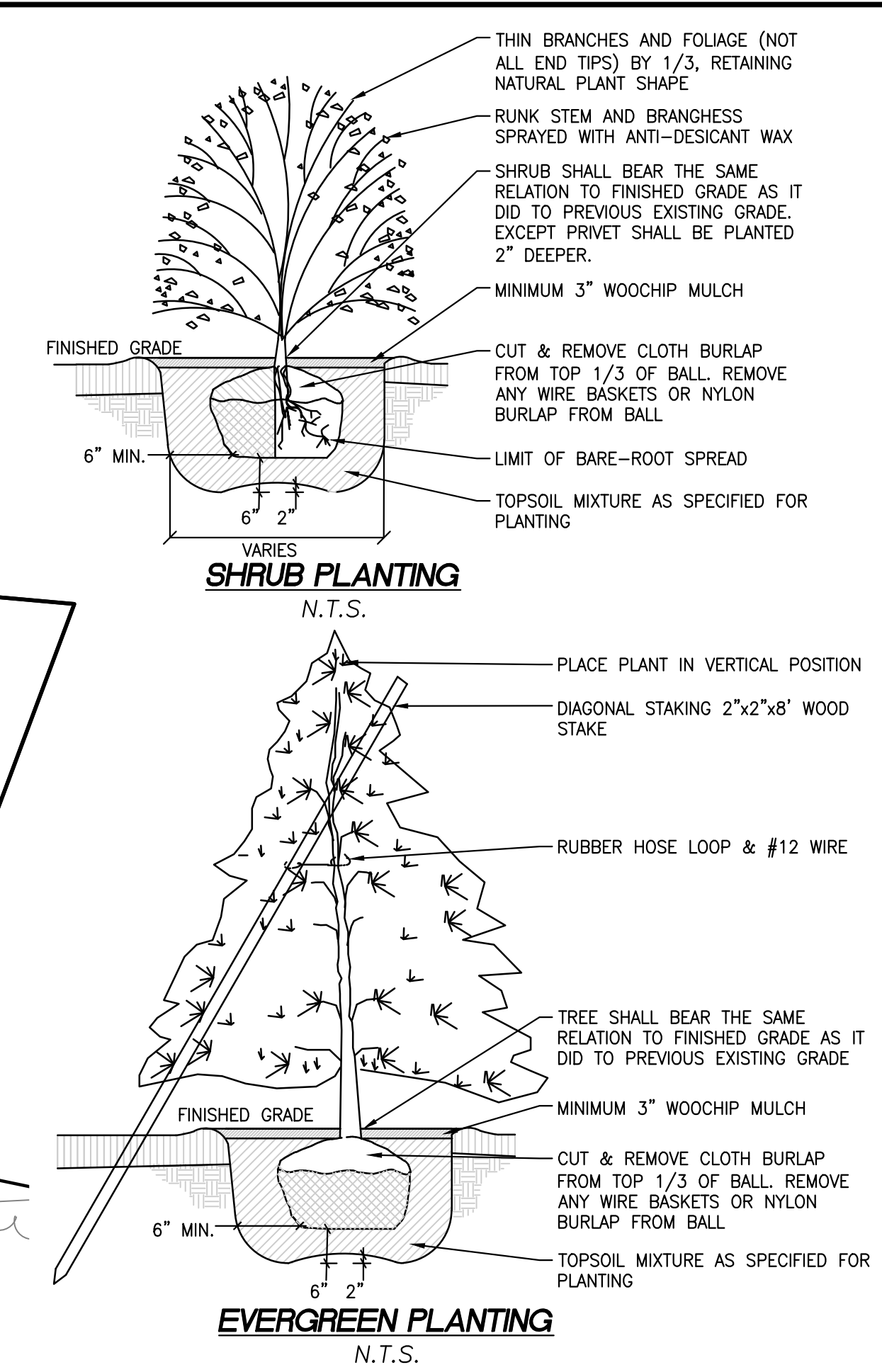
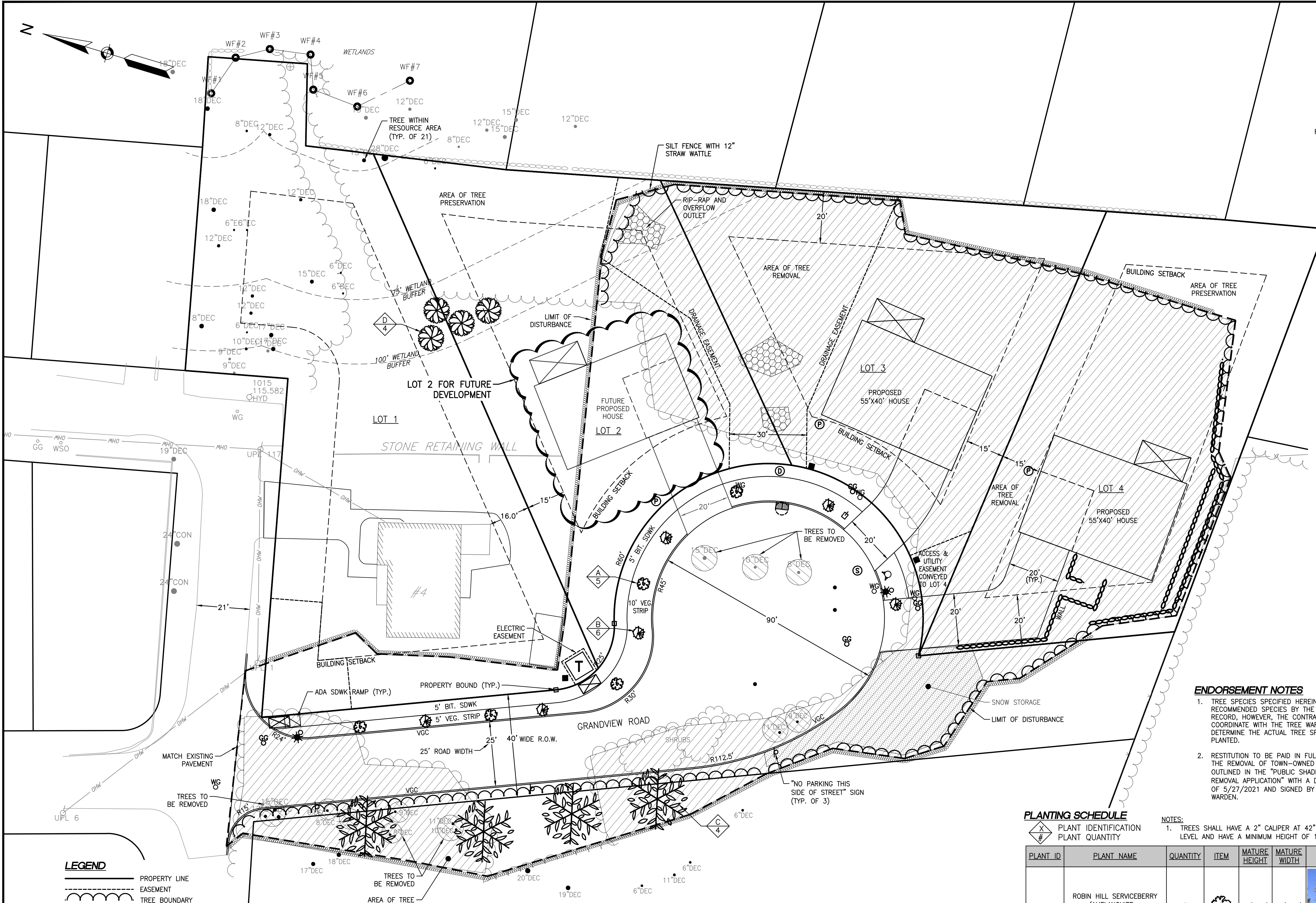

- GENERAL NOTES**
- ALL PLANT STOCK SHALL CONFORM TO ANSI Z260.1 - NURSERY STOCK, LATEST EDITION (AMERICAN ASSOCIATION OF NURSERYMEN, INC.).
  - NO TREES OR SHRUBS SHALL BE PLANTED AT THE STREET INTERSECTION WHERE THEY COULD BECOME A TRAFFIC HAZARD BY OBSTRUCTING VISION.
  - ALL TREES SHALL BE GUARANTEED BY THE DEVELOPER FOR THEIR ERRECTNESS AND GOOD HEALTH FOR TWO (2) YEARS AFTER PLANTING.
  - ALL AREAS DISTURBED DURING CONSTRUCTION SHALL BE LOAMED AND SEEDED. LOAM DEPTH SHALL BE A MINIMUM OF 4 INCHES. ALL LOAM PLACED SHALL BE pH CORRECTED AND FREE OF CLODS, LUMPS, STONES AND OTHER DELETERIOUS MATERIAL.
  - ANY DEAD VEGETATION SHALL BE REMOVED IMMEDIATELY AND REPLACED IN ACCORDANCE WITH THE SPECIFICATION ON PLAN.
  - OWNER SHALL MAINTAIN LANDSCAPE PLANTINGS TO ENSURE THE AESTHETIC APPEARANCE AND OVERALL PLANT HEALTHINESS IS RETAINED. THIS INCLUDES INSPECTING AND REPLACING PLANTINGS AS NECESSARY, WEEKLY MOWING AND MULCHING.
  - AN APPROVED SET OF PLANS AND ALL APPLICABLE PERMITS MUST BE AVAILABLE AT THE CONSTRUCTION SITE.
  - ANY DAMAGE TO PUBLIC OR PRIVATE PROPERTY RESULTING FROM CONSTRUCTION ACTIVITIES SHALL BE REPAIRED BY THE CONTRACTOR AT THEIR EXPENSE.
  - THE CONSTRUCTION SITE SHALL BE SECURED IN A MANNER SO AS TO PREVENT INJURY OR PROPERTY DAMAGE TO THE RESIDENTS OF THE TOWN.
  - AN APPROVED SITE AS-BUILT SHALL BE SUBMITTED TO THE ENGINEERING DIVISION WITHIN 60 DAYS OF CERTIFICATE OF OCCUPANCY. THE AS-BUILT SHALL BE SUBMITTED IN MYLAR AND ELECTRONIC ACAD FORMAT.
- ENDORSEMENT NOTES**
- TREE SPECIES SPECIFIED HEREIN ARE SIMPLY RECOMMENDED SPECIES BY THE ENGINEER OF RECORD, HOWEVER, THE CONTRACTOR SHALL COORDINATE WITH THE TREE WARDEN TO DETERMINE THE ACTUAL TREE SPECIES TO BE PLANTED.
  - RESTITUTION TO BE PAID IN FULL PRIOR TO THE REMOVAL OF TOWN-OWNED TREES AS OUTLINED IN THE "PUBLIC SHADE TREE REMOVAL APPLICATION" WITH A DATE OF ACTION OF 5/27/2021 AND SIGNED BY THE TREE WARDEN.

**PLANTING SCHEDULE**

PLANT ID	PLANT NAME	QUANTITY	ITEM	MATURE HEIGHT	MATURE WIDTH	IMAGE
A	ROBIN HILL SERVICEBERRY (AMELANCHIER x GRANDIFLORA 'ROBIN HILL')	5		15'-25'	12'-15'	
B	GOLDSPIRE GINKGO (GINKGO BILOBA 'GOLDSPIRE')	6		15'	5'-6'	
*C	SUGAR MAPLE TREE (ACER SACCHARUM)	4		60'-75'	40'-50'	
D	HIGHBUSH BLUEBERRY (VACCINIUM CORYMBOSUM)	4		6'-12'	8'-12'	

**TREE INVENTORY WITHIN WETLAND BUFFER ZONE**

TREE COUNT	
EXISTING TREE COUNT	21
TREES TO BE REMOVED	0
TOTAL TREES TO REMAIN	21

**TREE PRESERVATION CALCULATIONS**

	LOT 1	LOT 2	LOT 3	LOT 4	Grand View Rd.	TOTALS
LOT AREA, S.F.	22,112	15,002	15,026	15,104	22,164	89,408
NEW IMPERVIOUS, S.F.	0	2,388	2,526	2,998	12,572	23,549
SUM: OPEN SPACE, S.F.	*19,047	12,614	12,500	12,106	9,592	65,859
**REQUIRED # OF TREES	10	7	7	7	N/A	31
AREA OF TREE REMOVAL, S.F.	0	3,605	13,325	11,140	6,217	34,287
AREA OF TREE PRESERVED, S.F.	7,948	3,260	1,590	3,970	2,832	19,600
**ESTIMATED # OF TREES PRESERVED	20	14	7	17	12	70

**PERMANENT GRASS SEED MIX**

LITTLE BLUESTEM OR BROOMSEDGE	0.25
TUMBLE LOVEGRASS	0.10
SWITCHGRASS	0.10
BUSH CLOVER	0.10
RED TOP	0.10

- LEGEND**
- PROPERTY LINE
  - EASEMENT
  - TREE BOUNDARY
  - SNOW STORAGE AREA
  - RIP-RAP
  - TREE REMOVAL AREA
  - RETAINING WALL
  - BUILDING SETBACK
  - LIMIT OF DISTURBANCE
  - WETLAND BOUNDARY
  - WETLAND BUFFER
  - WF# WETLAND FLAG
  - VGC VERTICAL GRANITE CURB
  - DMH DRAIN MANHOLE
  - OOS OVERFLOW OUTLET STRUCTURE
  - WSG WATER VALVE
  - GS GAS VALVE
  - T ELECTRIC TRANSFORMER & EASEMENT
  - ELECTRIC SERVICE PULLBOX
  - ELECTRIC MANHOLE

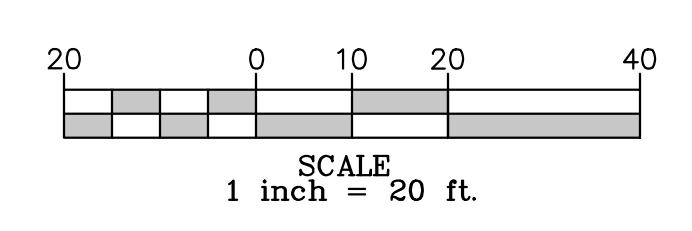

**SITE AND TREE PRESERVATION PLAN**  
SCALE: 1" = 20'



**REVISION**

REVISION	DATE	BY
REVISION 1	6/20/23	GGF

**PROJECT LOCATION:**  
LOTS 2, 3, & 4  
GRANDVIEW ROAD  
READING, MA 01867

**PARCEL ID:**  
MAP 27, LOT 404

**PLAN SET:**  
MAJOR SITE PLAN MODIFICATION  
GRANDVIEW ROAD SUBDIVISION - PRIVATE WAY  
(GRANDVIEW ROAD EXTENSION)

APRIL 20, 2023  
SCALE: 1" = 20'

**TOWN OF READING**  
COMMUNITY PLANNING & DEVELOPMENT COMMISSION

DATE: \_\_\_\_\_

FOR REGISTRY USE ONLY

**ENGINEER:** FODERA ENGINEERING  
617-877-3293  
28 Harbor St., Suite 204  
Danvers, MA 01923  
www.fodera.com

**SURVEYOR:** PFS Land Surveying, Inc.  
30 Balch Avenue  
Groveland, MA 01834  
P. 978.891.5203  
www.pfsland.com

**COPYRIGHT NOTICE:**  
This drawing is property of Fodera Engineering and is not to be used for any purpose other than the specific project and site named herein, and cannot be reproduced in any manner without the express written permission from the Firm's Principal.

**JOB NO.:** 20160-149  
**SHEET TITLE:** SITE AND TREE PRESERVATION  
**SHEET NUMBER:** C-2



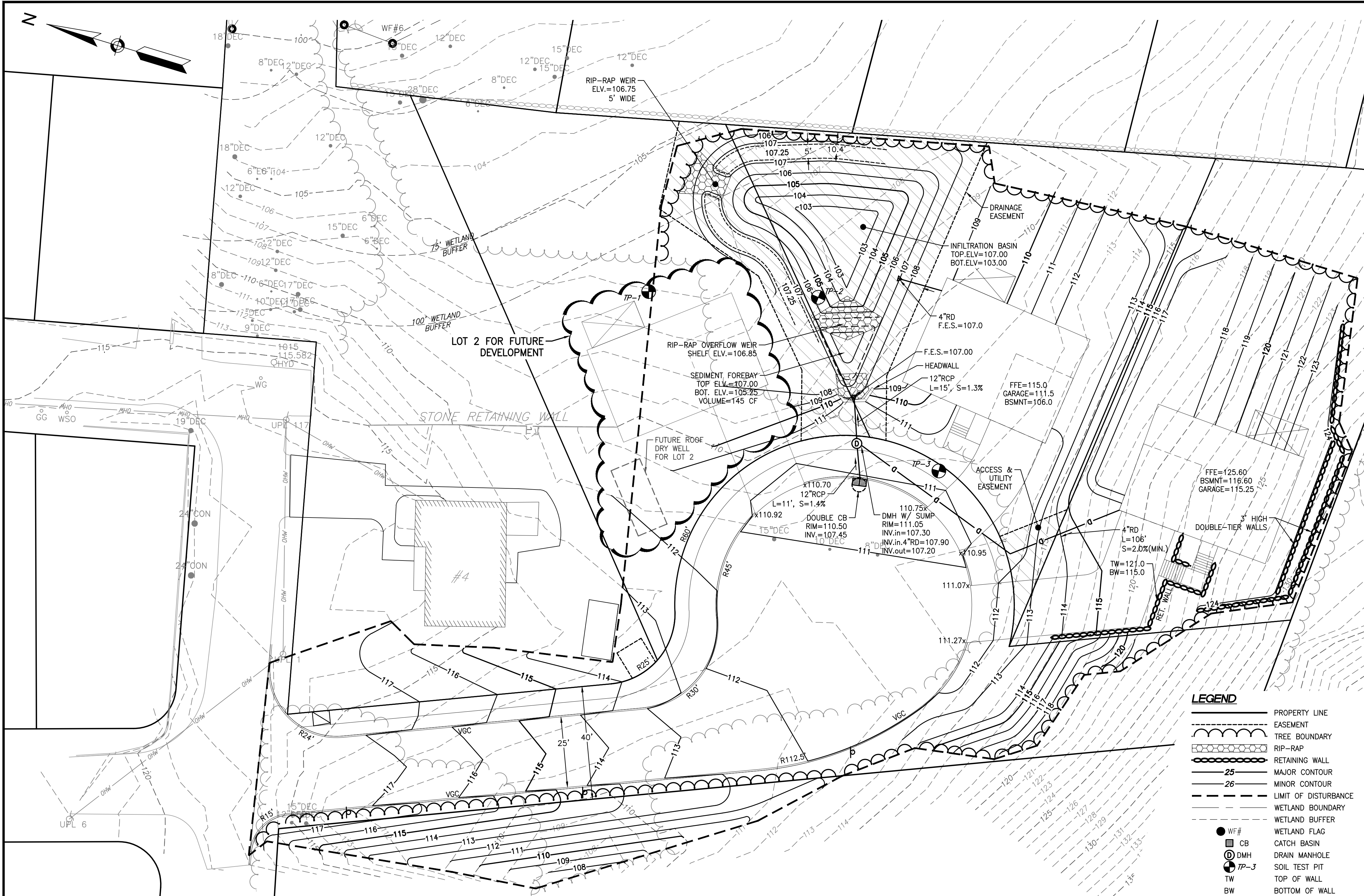

- ### GRADING AND DRAINAGE NOTES
- ALL CONSTRUCTION MATERIALS AND WORKMANSHIP SHALL BE IN ACCORDANCE TO THE TOWN'S LATEST CONSTRUCTION SPECIFICATIONS AND DETAILS.
  - GRADING IN THE RIGHT-OF-WAY SHALL IN ACCORDANCE WITH LOCAL REGULATIONS, UNLESS OTHERWISE APPROVED BY THE TOWN.
  - THE CONTRACTOR SHALL NOTIFY DIG SAFE AND THE TOWN A MINIMUM OF 72 HOURS PRIOR TO THE START OF ANY EXCAVATIONS.
  - INSTALL ALL APPROPRIATE TREE PROTECTION MEASURES PRIOR TO GRADING AND EXCAVATION.
  - EXACT LOCATIONS OF SAW-CUTTING MAY BE FIELD DETERMINED BASED ON EXISTING PAVEMENT CONDITIONS.
  - THE CONTRACTOR SHALL CAREFULLY PRESERVE BENCHMARKS, REFERENCE POINTS AND STAKES.
  - EROSION CONTROL MEASURES SHALL BE STABILIZED IN PLACE BEFORE BEGINNING SITE WORK. THESE MEASURES SHALL BE MAINTAINED THROUGHOUT CONSTRUCTION.
  - ALL INDICATED ELEVATIONS ARE FINISHED ELEVATIONS.
  - LOCATE AND PROTECT ALL UTILITIES ASSOCIATED WITH THE PROJECT PRIOR TO CONSTRUCTION.
  - ALL EXCAVATION SHALL INCLUDE CLEARING, STRIPPING AND STOCKPILING TOPSOIL, REMOVING UNSUITABLE MATERIALS, THE CONSTRUCTION OF EMBANKMENTS, CONSTRUCTION FILLS, AND THE FINAL SHAPING AND TRIMMING TO THE LINES AND GRADES SHOWN ON THE PLANS.
  - ALL TREES, BRUSH, AND ORGANIC TOPSOIL AND OTHER OBJECTIONABLE MATERIAL SHALL BE REMOVED, UNLESS OTHERWISE SPECIFIED, AND DISPOSED OF AT AN OFF-SITE LOCATION, WITH THE EXCEPTION THAT ENOUGH TOPSOIL SHALL BE RETAINED FOR RE-SPREAD AND GENERAL LANDSCAPING AREAS WHICH ARE TO BE FILLED SHALL BE COMPACTED TO A MINIMUM DENSITY OF 95% AS DETERMINED BY THE MODIFIED PROCTOR (ASTM D1557, METHOD C) COMPACTION TEST IN THE PAVED AREAS AND 90% IN THE OTHER AREAS.
  - CONTRACTOR SHALL PROVIDE POSITIVE DRAINAGE TO ALL INLETS AND CATCH BASINS. AREAS OF SURFACE PONDING SHALL BE CORRECTED BY CONTRACTOR AT NO ADDITIONAL EXPENSE TO THE OWNER.
  - IF AREAS ARE DISTURBED BEYOND PROPOSED GRADES BY NEGLIGENCE OF THE CONTRACTOR, THE CONTRACTOR SHALL BE HELD RESPONSIBLE FOR ANY REGRADING OR REPAIR TO MATCH ORIGINAL EXISTING CONDITIONS.
  - SHORING SHALL BE DONE AS NECESSARY FOR THE PROTECTION OF THE WORK AND FOR THE SAFETY OF PERSONNEL. SHORING SHALL BE IN ACCORDANCE WITH ALL O.S.H.A AND LOCAL REGULATIONS.
  - CONTRACTOR SHALL ADJUST GRADES BY VARYING THE PAVEMENT SECTIONS ACCORDINGLY. EXISTING COMPACTED SUBGRADE TO BE DISTURBED AS LITTLE AS POSSIBLE.
  - ALL PROPOSED SPOT ELEVATIONS SHOWN INDICATE FINISHED GRADED ELEVATIONS AT EDGE OF PAVEMENT AND/OR GRADE BREAKS, UNLESS OTHERWISE NOTED.
  - MAINTAIN PROPER SITE DRAINAGE AT ALL TIMES DURING THE COURSE OF CONSTRUCTION, AND PREVENT STORM WATER FROM RUNNING INTO OR STANDING IN EXCAVATED AREAS.
  - SPREAD AND COMPACT UNIFORMLY TO THE DEGREE SPECIFIED ALL EXCESS TRENCH SPOIL AFTER COMPLETION OF THE UNDERGROUND IMPROVEMENTS (EARTHWORK CONTRACTOR SHALL MAKE APPROPRIATE ADJUSTMENTS IN ROUGH GRADING TO ACCOMMODATE TRENCH SPOIL).
  - PROVIDE WATER TO ADD TO DRY MATERIAL IN ORDER TO ADJUST THE MOISTURE CONTENT FOR THE PURPOSE OF ACHIEVING THE SPECIFIED COMPACTION.
  - UNSUITABLE MATERIAL SHALL BE CONSIDERED AS MATERIAL WHICH IS NOT SUITABLE FOR THE SUPPORT OF PAVEMENT AND BUILDING CONSTRUCTION, AND IS ENCOUNTERED BELOW NORMAL TOPSOIL DEPTHS AND THE PROPOSED SUB-GRADE ELEVATION. THE DECISION TO REMOVE SAID MATERIAL, AND TO WHAT EXTENT, SHALL BE MADE BY A SOILS ENGINEER WITH THE CONCURRENCE OF THE OWNER.
  - REPAIR ANY BASE COURSE AND BINDER COURSE FAILURES PRIOR TO THE INSTALLATION OF THE FINAL BITUMINOUS CONCRETE SURFACE COURSE.
  - SWEEP CLEAN THE BINDER COURSE PRIOR TO THE INSTALLATION OF THE FINAL BITUMINOUS CONCRETE SURFACE COURSE. EXCESSIVE CLEANING OF THE BINDER COURSE THAT MAY BE REQUIRED, AND IS NOT THE FAULT OF THE PAVING CONTRACTOR, SHALL BE PAID FOR ON A TIME AND MATERIAL BASIS BY PRIOR AGREEMENT WITH THE GENERAL CONTRACTOR.
  - CONFIRM INVERTS OF ALL EXISTING STORM INLETS AND SANITARY SEWER MANHOLES BEFORE COMMENCING CONSTRUCTION.
  - A GEOTEXTILE MATTING (LANDLOCK TRM 450 OR EQUIVALENT) SHALL BE USED FOR EROSION CONTROL ON ALL SLOPES GREATER THAN 3H:1V IF NECESSARY.
  - DRAINAGE STRUCTURES AND UNDERGROUND INFILTRATION FACILITIES SHALL BE INSPECTED SEMIANNUALLY TO ENSURE PROPER WORKING ORDER.
  - UNSUITABLE EXISTING SOILS, SILT, AND DEBRIS SHALL BE ADEQUATELY REMOVED FROM THE AREA OF THE PROPOSED INFILTRATION BASIN. REMOVE ALL ORGANICS.
  - IF THE CONTRACTOR IN THE COURSE OF WORK FINDS ANY DISCREPANCIES BETWEEN THE PLANS AND THE PHYSICAL CONDITIONS OF THE LOCALITY, OR ANY ERRORS OR OMISSIONS IN THE PLANS OR IN THE LAYOUT AS GIVEN BY THE ENGINEER, IT SHALL BE HIS DUTY TO IMMEDIATELY INFORM THE ENGINEER, IN WRITING AND THE ENGINEER WILL PROMPTLY VERIFY THE SAME. ANY WORK DONE AFTER SUCH A DISCOVERY, UNTIL AUTHORIZED, WILL BE AT THE CONTRACTOR'S RISK.
  - ANNUAL O&M REPORTS SHALL BE DELIVERED TO THE OFFICE OF THE TOWN ENGINEER BY JANUARY 15 OF EACH YEAR.
  - ANY RETAINING WALL OVER FOUR (4) FEET IN RETAINED HEIGHT SHALL REQUIRE AN ENGINEERED DESIGN FROM A DESIGN PROFESSIONAL.

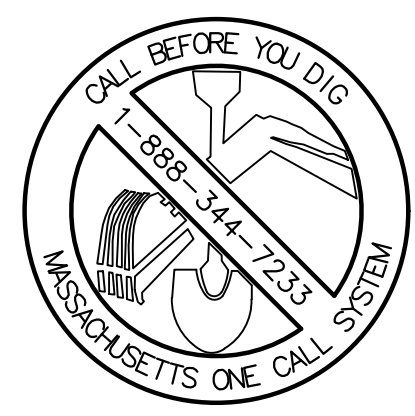

REVISION	DATE	BY
REVISION 1	6/20/23	GGF

PROJECT LOCATION:  
 LOTS 2, 3, & 4  
 GRANDVIEW ROAD  
 READING, MA 01867  
 PARCEL ID:  
 MAP 27, LOT 404

PLAN SET:  
**MAJOR SITE PLAN MODIFICATION**  
**GRANDVIEW ROAD SUBDIVISION - PRIVATE WAY**  
**(GRANDVIEW ROAD EXTENSION)**  
 APRIL 20, 2023  
 SCALE: 1" = 20'

**GRADING AND DRAINAGE PLAN**  
 SCALE: 1" = 20'

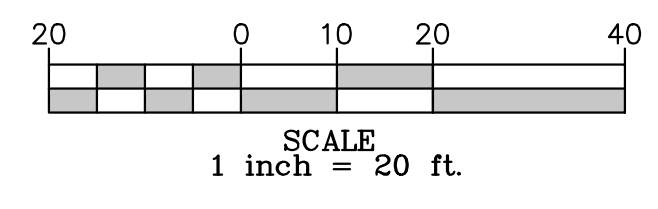

**LEGEND**

—	PROPERTY LINE
- - -	EASEMENT
—○—	TREE BOUNDARY
—●—	RIP-RAP
—■—	RETAINING WALL
—	MAJOR CONTOUR
—	MINOR CONTOUR
—	LIMIT OF DISTURBANCE
- - -	WETLAND BOUNDARY
- - -	WETLAND BUFFER
● WF #	WETLAND FLAG
■ CB	CATCH BASIN
○ DMH	DRAIN MANHOLE
○ TP-3	SOIL TEST PIT
○	TOP OF WALL
○	TW
○	BOTTOM OF WALL
○	T.O.F.
○	TOP OF FOUNDATION
○	FFE
○	RIM
○	INV
○	O.O.S.
○	F.E.S.
○	OVERFLOW OUTLET STRUCTURE
○	FLARED END SECTION

**SOIL TEST RESULTS**  
 TEST DATE: 7/6/2020  
 WEATHER: 65°F, SUNNY/ DRY  
 SOIL EVALUATOR: ARMAND PORRAZZO  
 LICENCE #: 1958

TP-1	TP-2	TP-3																																																																		
<table border="1"> <tr><th>ELV. DPT.</th><th>Soil Data</th></tr> <tr><td>106 0"</td><td>A (0"-9")</td></tr> <tr><td>105 9"</td><td>Sandy Loam</td></tr> <tr><td>104 24"</td><td>10YR 3/2</td></tr> <tr><td>103 36"</td><td>B (9"-24")</td></tr> <tr><td>102 7/6</td><td>Sandy Loam</td></tr> <tr><td>101 7/6</td><td>10YR 7/6</td></tr> <tr><td>100 7/6</td><td>C (24"-108")</td></tr> <tr><td>99 4/3</td><td>Loamy Sand</td></tr> <tr><td>98 4/3</td><td>2.5Y 4/3</td></tr> </table>	ELV. DPT.	Soil Data	106 0"	A (0"-9")	105 9"	Sandy Loam	104 24"	10YR 3/2	103 36"	B (9"-24")	102 7/6	Sandy Loam	101 7/6	10YR 7/6	100 7/6	C (24"-108")	99 4/3	Loamy Sand	98 4/3	2.5Y 4/3	<table border="1"> <tr><th>ELV. DPT.</th><th>Soil Data</th></tr> <tr><td>108 0"</td><td>A (0"-12")</td></tr> <tr><td>107 12"</td><td>Sandy Loam</td></tr> <tr><td>106 36"</td><td>10YR 3/2</td></tr> <tr><td>105 36"</td><td>B (12"-36")</td></tr> <tr><td>104 36"</td><td>Sandy Loam</td></tr> <tr><td>103 5/2</td><td>10YR 7/6</td></tr> <tr><td>102 5/2</td><td>C (36"-80")</td></tr> <tr><td>101 5/2</td><td>Loamy Sand</td></tr> <tr><td>100 5/2</td><td>2.5Y 5/2</td></tr> <tr><td>99 5/2</td><td>C (80"-120")</td></tr> <tr><td>98 5/2</td><td>Sand Gravel</td></tr> <tr><td>97 5/2</td><td>2.5Y 4/3</td></tr> </table>	ELV. DPT.	Soil Data	108 0"	A (0"-12")	107 12"	Sandy Loam	106 36"	10YR 3/2	105 36"	B (12"-36")	104 36"	Sandy Loam	103 5/2	10YR 7/6	102 5/2	C (36"-80")	101 5/2	Loamy Sand	100 5/2	2.5Y 5/2	99 5/2	C (80"-120")	98 5/2	Sand Gravel	97 5/2	2.5Y 4/3	<table border="1"> <tr><th>ELV. DPT.</th><th>Soil Data</th></tr> <tr><td>112 0"</td><td>A (0"-8")</td></tr> <tr><td>111 8"</td><td>Sandy Loam</td></tr> <tr><td>110 27"</td><td>10YR 3/2</td></tr> <tr><td>109 27"</td><td>B (8"-27")</td></tr> <tr><td>108 7/6</td><td>Sandy Loam</td></tr> <tr><td>107 7/6</td><td>10YR 7/6</td></tr> <tr><td>106 66"</td><td>C (27"-66")</td></tr> <tr><td>105 5/2</td><td>Loamy Sand</td></tr> <tr><td>104 5/2</td><td>2.5Y 5/2</td></tr> </table>	ELV. DPT.	Soil Data	112 0"	A (0"-8")	111 8"	Sandy Loam	110 27"	10YR 3/2	109 27"	B (8"-27")	108 7/6	Sandy Loam	107 7/6	10YR 7/6	106 66"	C (27"-66")	105 5/2	Loamy Sand	104 5/2	2.5Y 5/2
ELV. DPT.	Soil Data																																																																			
106 0"	A (0"-9")																																																																			
105 9"	Sandy Loam																																																																			
104 24"	10YR 3/2																																																																			
103 36"	B (9"-24")																																																																			
102 7/6	Sandy Loam																																																																			
101 7/6	10YR 7/6																																																																			
100 7/6	C (24"-108")																																																																			
99 4/3	Loamy Sand																																																																			
98 4/3	2.5Y 4/3																																																																			
ELV. DPT.	Soil Data																																																																			
108 0"	A (0"-12")																																																																			
107 12"	Sandy Loam																																																																			
106 36"	10YR 3/2																																																																			
105 36"	B (12"-36")																																																																			
104 36"	Sandy Loam																																																																			
103 5/2	10YR 7/6																																																																			
102 5/2	C (36"-80")																																																																			
101 5/2	Loamy Sand																																																																			
100 5/2	2.5Y 5/2																																																																			
99 5/2	C (80"-120")																																																																			
98 5/2	Sand Gravel																																																																			
97 5/2	2.5Y 4/3																																																																			
ELV. DPT.	Soil Data																																																																			
112 0"	A (0"-8")																																																																			
111 8"	Sandy Loam																																																																			
110 27"	10YR 3/2																																																																			
109 27"	B (8"-27")																																																																			
108 7/6	Sandy Loam																																																																			
107 7/6	10YR 7/6																																																																			
106 66"	C (27"-66")																																																																			
105 5/2	Loamy Sand																																																																			
104 5/2	2.5Y 5/2																																																																			
NO REFUSAL NO WEEPING REDOX @ 60" ESHWT = 101.0	NO REFUSAL NO WEEPING NO REDOX	NO REFUSAL NO WEEPING NO REDOX																																																																		

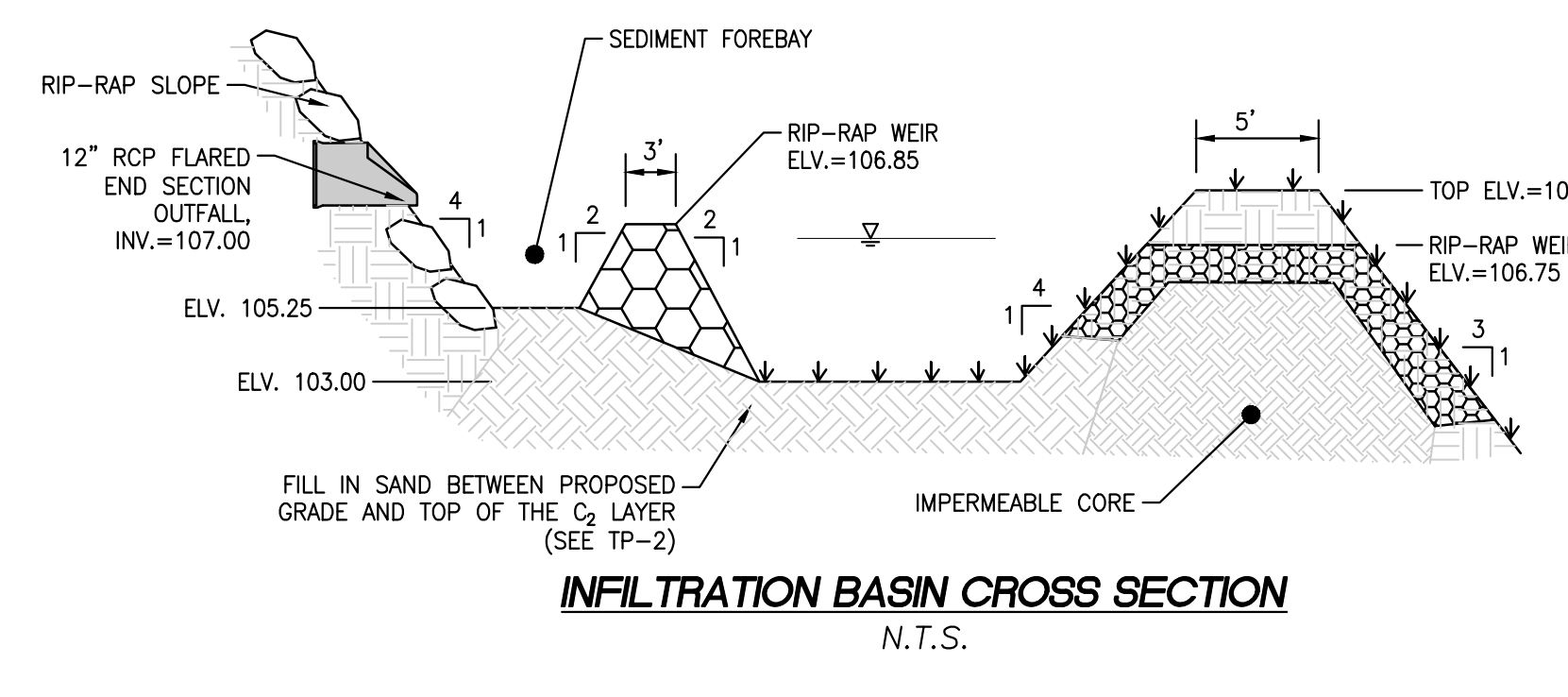
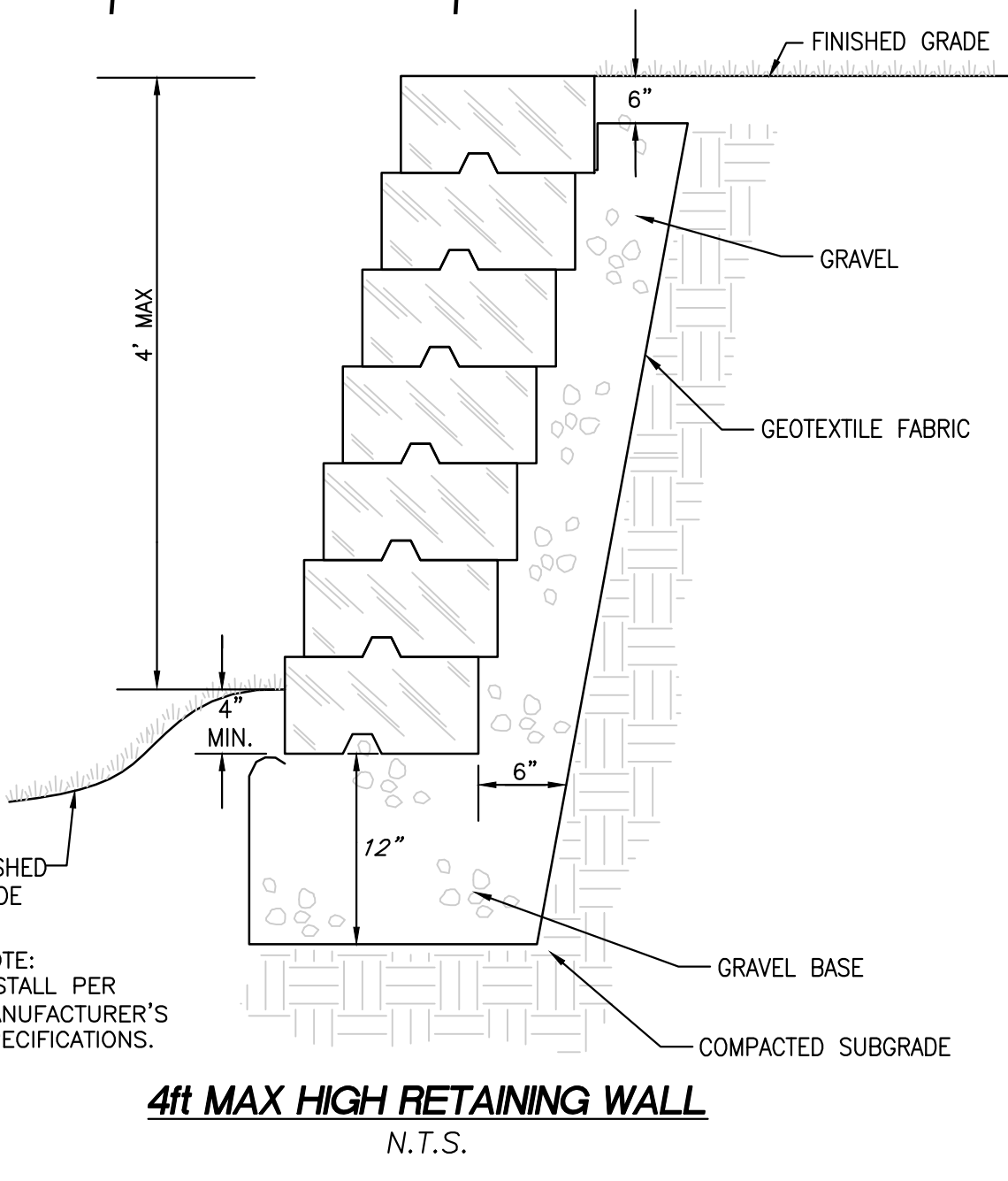

TOWN OF READING  
 COMMUNITY PLANNING & DEVELOPMENT COMMISSION  
 DATE: \_\_\_\_\_  
 \_\_\_\_\_  
 \_\_\_\_\_  
 \_\_\_\_\_

FOR REGISTRY USE ONLY  
 \_\_\_\_\_  
 \_\_\_\_\_  
 \_\_\_\_\_

**ENGINEER:**  
**FODERA ENGINEERING**  
 (617) 877-3293  
 gfodera@foderaengineering.com  
 28 Harbor St., Suite 204  
 Danvers, MA 01923  
 www.fodera.com

**SURVEYOR:**  
**PFS Land Surveying, Inc.**  
 20 Balch Avenue  
 Groveland, MA 01834  
 P. 978.891.5203  
 www.pfsland.com

PROFESSIONAL SEAL  
 GIOVANNI GAETANO FODERA  
 No. 56834  
 JOB # 20160  
 APRIL 20, 2023  
 G.F. 4/23

**COPYRIGHT NOTICE**  
 This drawing is property of Fodera Engineering and is not to be used for any purpose other than the specific project and site named herein, and cannot be reproduced in any manner without the express written permission from the Firm's Principal.

**JOB NO.:** 20160-149  
**SHEET TITLE:**  
**GRADING AND DRAINAGE PLAN**  
**SHEET NUMBER:**  
 C-4

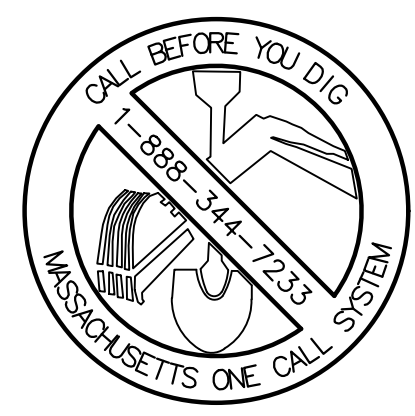

**SEWAGE CALCULATIONS**  
 ASSUMPTIONS MADE FOR EACH PROPOSED HOUSE TO CONTAIN FOUR (4) BEDROOMS. CALCULATIONS BELOW ARE IN ACCORDANCE TO 310 CMR 15.00.  
 3 NEW HOUSES \* 4 BEDROOMS PER HOUSE = 12 BEDROOMS ADDED  
 12 BEDROOMS \* 110 GAL/DAY = 1,320 GAL/DAY OF ADDED SEWAGE

REVISION	DATE	BY
REVISION 1	6/20/23	GGF

- UTILITY NOTES**
- CONTRACTOR IS TO VERIFY THE LOCATION OF ALL EXISTING UTILITIES PRIOR TO CONSTRUCTION AND ENSURE NO CONFLICTS EXIST WITH PROPOSED IMPROVEMENTS. NOTIFY ENGINEER IMMEDIATELY IF UTILITIES ARE LOCATED DIFFERENTLY THAN SHOWN. THE CONTRACTOR SHALL COORDINATE WITH EACH RESPECTIVE UTILITY COMPANY IN ORDER TO RELOCATE IF NEEDED IN CONFORMANCE WITH THEIR GUIDELINES.
  - CONTRACTOR SHALL NOTIFY AND COORDINATE WITH THE APPROPRIATE UTILITY COMPANY PRIOR TO THE REMOVAL OF INDICATED UTILITIES ON SITE. CONTRACTOR SHALL BE RESPONSIBLE FOR OBTAINING ANY PERMITS REQUIRED FOR DEMOLITION AND HULL OFF FROM THE APPROPRIATE AUTHORITIES.
  - THE DEPARTMENT OF PUBLIC WORKS OR APPLICABLE GOVERNING DEPARTMENT MUST AUTHORIZE AND PERMIT TO CONSTRUCT, ALTER OR MODIFY A WATER OR SEWER LINE.
  - AT THE COMPLETION OF THE WATER AND/OR SEWER CONSTRUCTION AND PRIOR TO RECORDING THE FINAL PLAN, THE CONTRACTOR WILL FURNISH THE WATER SYSTEM INSPECTOR RECORD DRAWINGS OF THE PROJECT.
  - BUILDING CONTRACTOR SHALL BE RESPONSIBLE FOR COORDINATION WITH THE GAS COMPANY FOR THE CONSTRUCTION OF THE GAS LINE BETWEEN METER AND MAIN.
  - BUILDING CONTRACTOR SHALL BE RESPONSIBLE FOR COORDINATION WITH THE POWER COMPANY FOR THE CONSTRUCTION OF ELECTRICAL CONDUIT TO PROVIDE SERVICE AND IF A TRANSFORMER IS REQUIRED TO BE INSTALLED.
  - THE CONTRACTOR SHALL BE RESPONSIBLE FOR VERIFYING, PRIOR TO CONSTRUCTION, ALL EXISTING LOCATIONS AND INVERT ELEVATIONS OF SANITARY SEWERS, STORM DRAINAGE, AND WATER MAINS. IF ANY INVERT ELEVATION VARIES MORE THAN 0.1 FT. FROM RECORD ELEVATIONS, THE CONTRACTOR SHALL NOTIFY THE ENGINEER IMMEDIATELY. WORK SHALL NOT PROCEED UNTIL THE CONTRACTOR IS NOTIFIED BY THE ENGINEER.
  - CONNECT TO EXISTING UTILITIES AND INSTALL UTILITIES IN COMPLIANCE WITH REQUIREMENTS OF APPROPRIATE JURISDICTIONAL AGENCIES.
  - COORDINATE WITH BUILDING PLANS TO ASSURE ACCURACY OF UTILITY CONNECTIONS AND COMPLIANCE WITH LOCAL CODES.
  - ALL SEWERS TO BE MAINTAINED THROUGHOUT CONSTRUCTION, INCLUDING CLEANING OF ANY SILT OR DEBRIS ACCUMULATED IN STRUCTURES.
  - ALL SURPLUS EXCAVATED MATERIAL FROM THE TRENCH SHALL BE DISPOSED OFF THE SITE BY CONTRACTOR.
  - TRENCHING SHOULD BE CONDUCTED IN ACCORDANCE WITH ALL OSHA REGULATIONS.
  - COORDINATE EXACT TRENCHING, ROUTING, AND POINT OF TERMINATION WITH ALL UTILITY COMPANIES.
  - BACKFILL MATERIAL SHALL BE SUITABLE MATERIAL IN COMPLIANCE WITH THE TOWN OF DANVERS AND/OR THE MASSACHUSETTS DEPARTMENT OF TRANSPORTATION (MASSDOT).
  - WATER MAIN SHALL HAVE A MINIMUM COVER OF FIVE (5) FEET.
  - THE SANITARY SEWER AND POTABLE WATER LINES ARE TO BE SEPARATED BY AT LEAST 10 FEET HORIZONTALLY, OR THE POTABLE WATER LINE SHALL BE AT LEAST 18 INCHES VERTICALLY ABOVE THE SANITARY SEWER.
  - CONTRACTOR TO RECONFIGURE PROPOSED ELECTRIC/TELEPHONE/CABLE CONDUITS AS NECESSARY TO AVOID CONFLICT WITH TREES/LANDSCAPING.
  - THRUST BLOCKS TO BE PLACED AT ALL BEND LOCATIONS WITHIN THE POTABLE WATER LINES. SEE DETAIL SHEETS.
  - ALL UTILITIES SHALL BE APPROVED MATERIALS AND INSTALLED IN ACCORDANCE WITH THE DEPARTMENT OF PUBLIC WORKS STANDARDS.
  - THE TOWN'S ENGINEERING DIVISION SHALL BE NOTIFIED SEVENTY-TWO (72) HOURS PRIOR TO ANY EXCAVATION TO MARK OUT TOWN UTILITIES.

**PROJECT LOCATION:**  
 LOTS 2, 3 + 4  
 GRANDVIEW ROAD  
 READING, MA 01867  
**PARCEL ID:**  
 MAP 27, LOT 404

**PLAN SET:**  
 MAJOR SITE PLAN MODIFICATION  
 GRANDVIEW ROAD SUBDIVISION - PRIVATE WAY  
 (GRANDVIEW ROAD EXTENSION)  
 SCALE: 1" = 20'

FOR REGISTRY USE ONLY

TOWN OF READING  
 COMMUNITY PLANNING & DEVELOPMENT COMMISSION

DATE: \_\_\_\_\_

**ENGINEER:**  
**FODERA ENGINEERING**  
 (617) 877-3293  
 gfodera@foderaengineering.com  
 28 Harbor St., Suite 204  
 Danvers, MA 01923  
 PROFESSIONAL SEAL

**SURVEYOR:**  
**PFS Land Surveying, Inc.**  
 30 Balch Avenue  
 Groveland, MA 01834  
 P.978.891.5203  
 www.pfsland.com  
 PROFESSIONAL SEAL

**COPYRIGHT NOTICE**  
 This drawing is property of Fodera Engineering and is not to be used for any purpose other than the specific project and site named herein, and cannot be reproduced in any manner without the express written permission from the Firm's Principal.

**JOB NO.:** 20160-149  
**SHEET TITLE:** UTILITY + ROADWAY PROFILE PLAN  
**SHEET NUMBER:** C-5

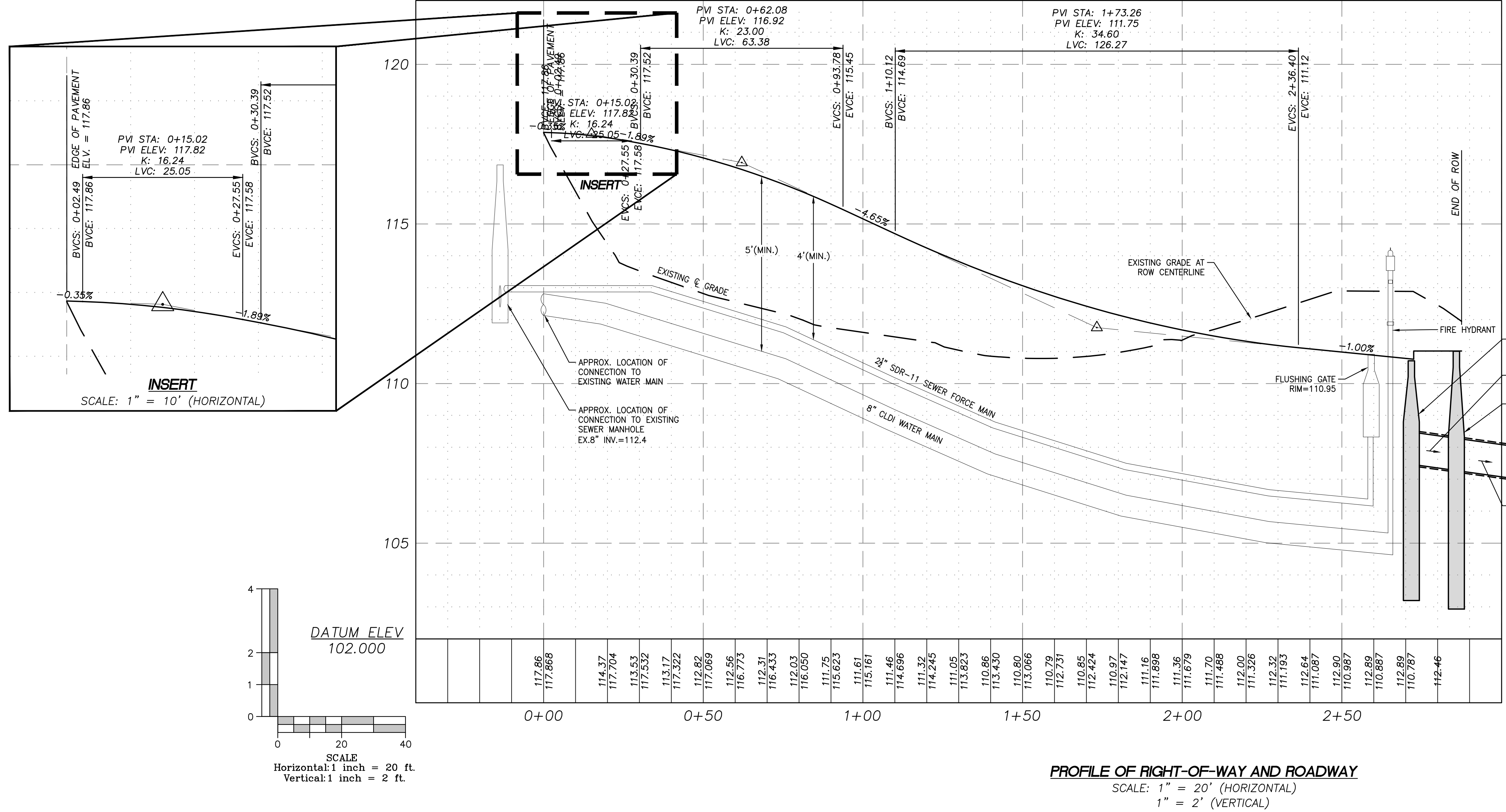
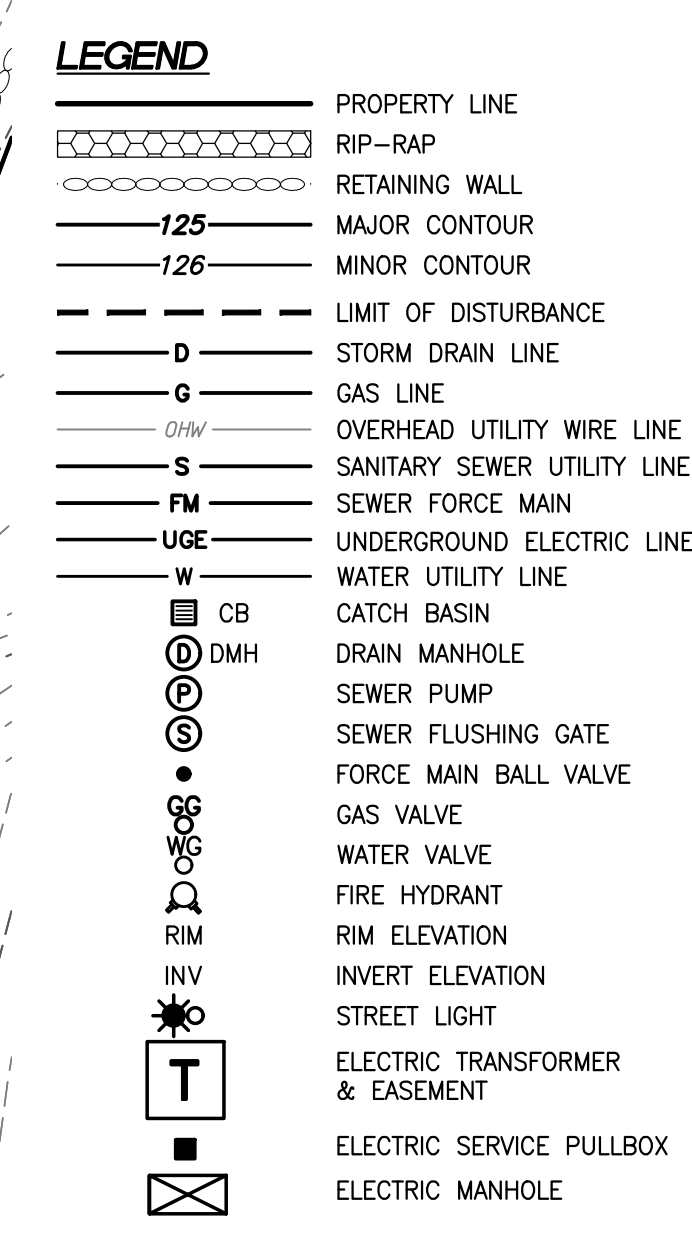
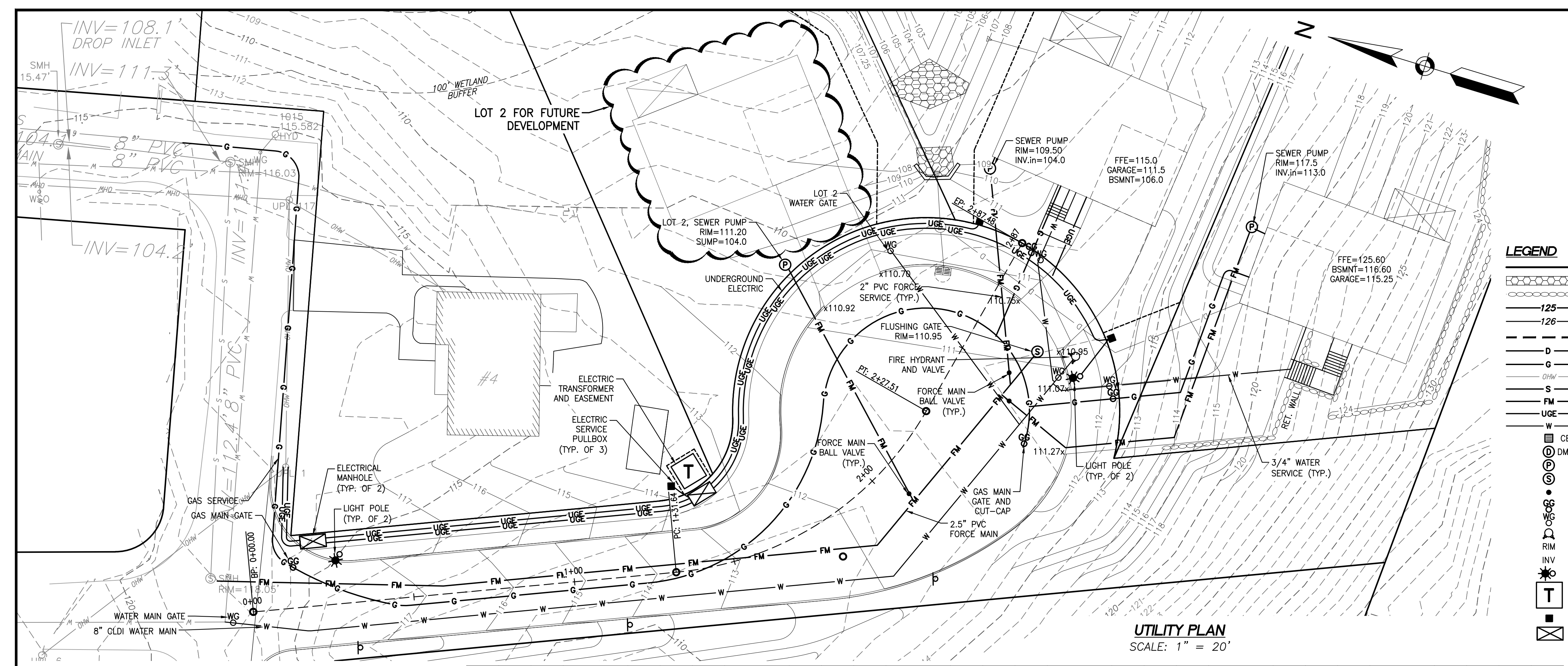

**UTILITY AND ROADWAY PROFILE PLAN**  
 SCALE: 1" = 20' (HORIZONTAL)

**PROFILE OF RIGHT-OF-WAY AND ROADWAY**  
 SCALE: 1" = 20' (HORIZONTAL)  
 1" = 2' (VERTICAL)

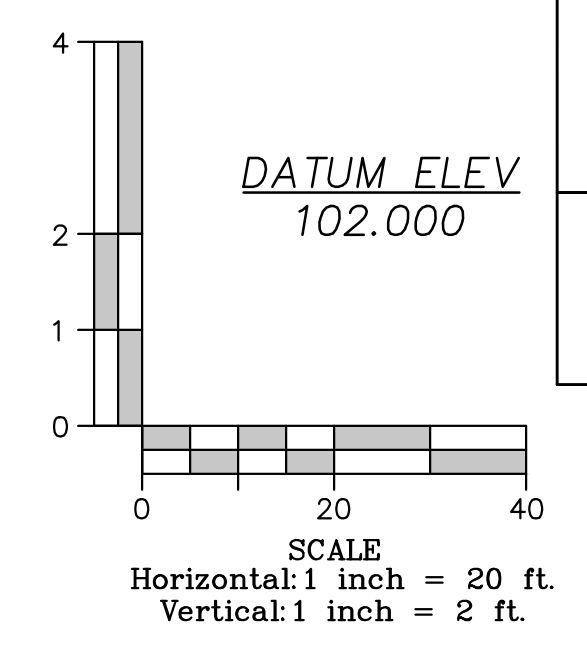

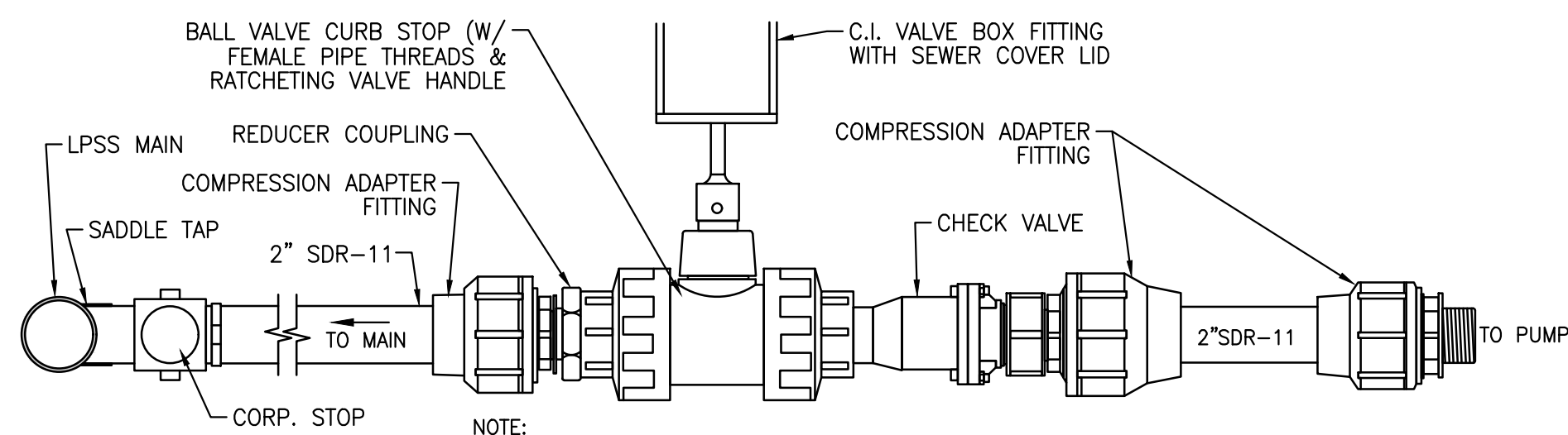

**LOW PRESSURE SEWER SERVICE LATERAL VALVE AND CONNECTION**  
N.T.S.

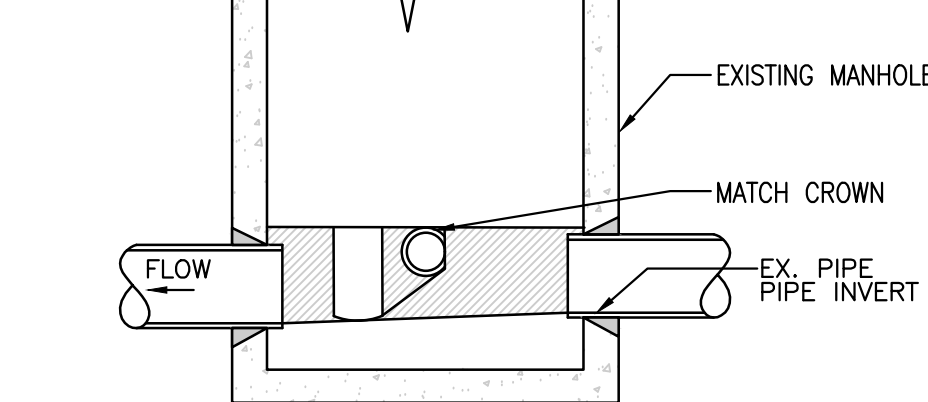

**CONNECTION TO EXISTING SEWER MANHOLE**  
N.T.S.

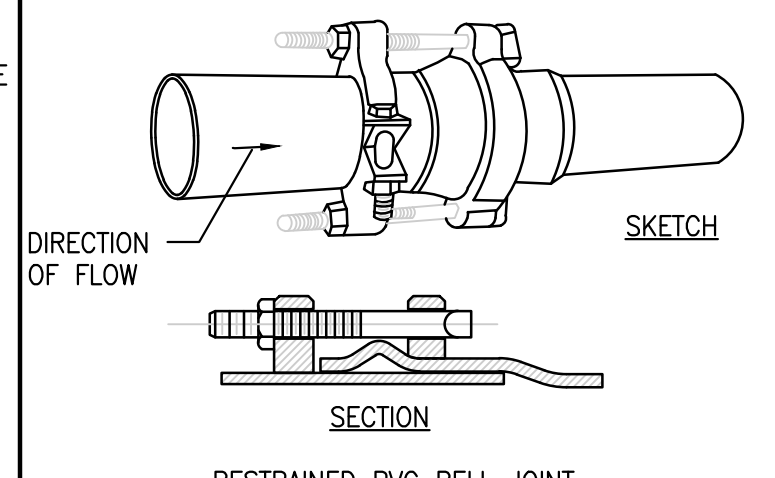

**RESTRAINED MECHANICAL JOINT FITTING**  
N.T.S.

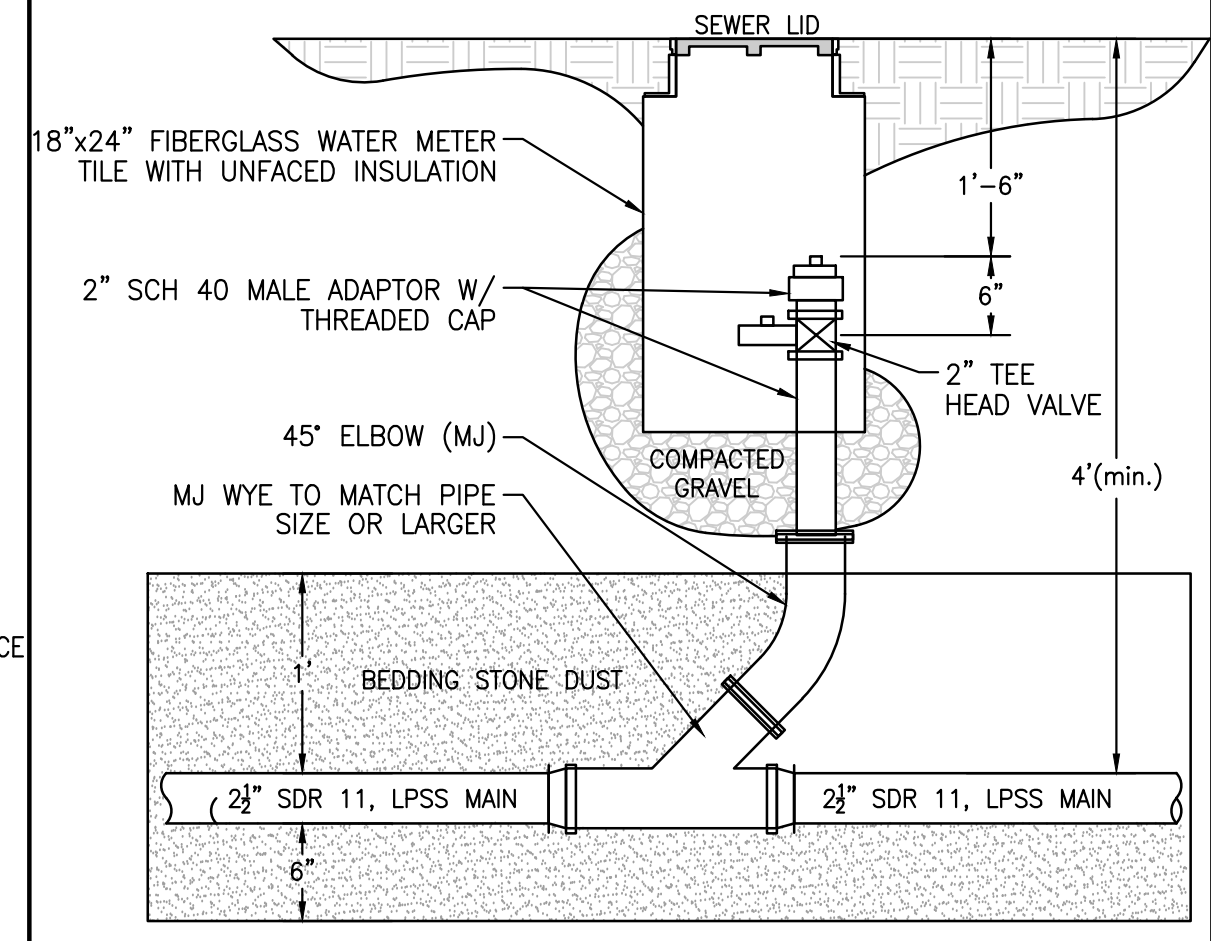

**SEWER FORCE MAIN FLUSHING CONNECTION**  
N.T.S.

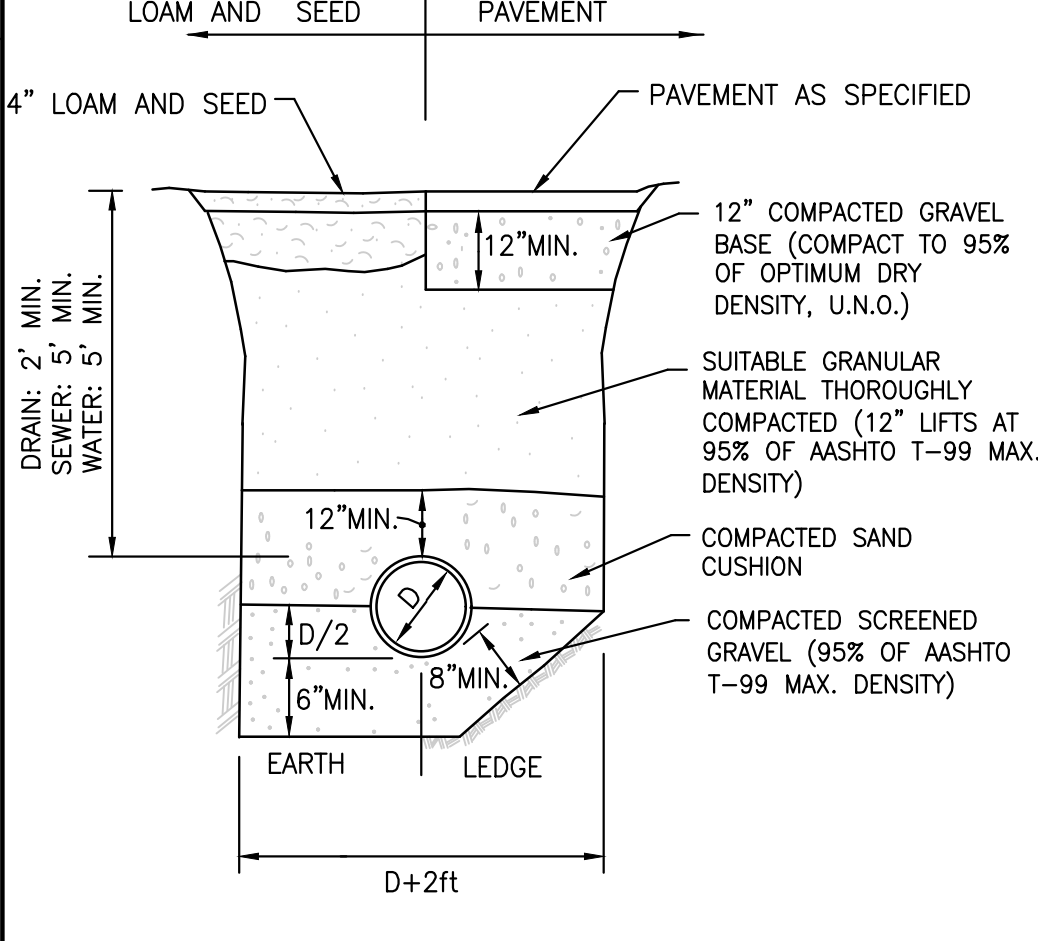

**DRAIN/ SEWER/ WATER TRENCH AND BACKFILL DETAIL**  
N.T.S.

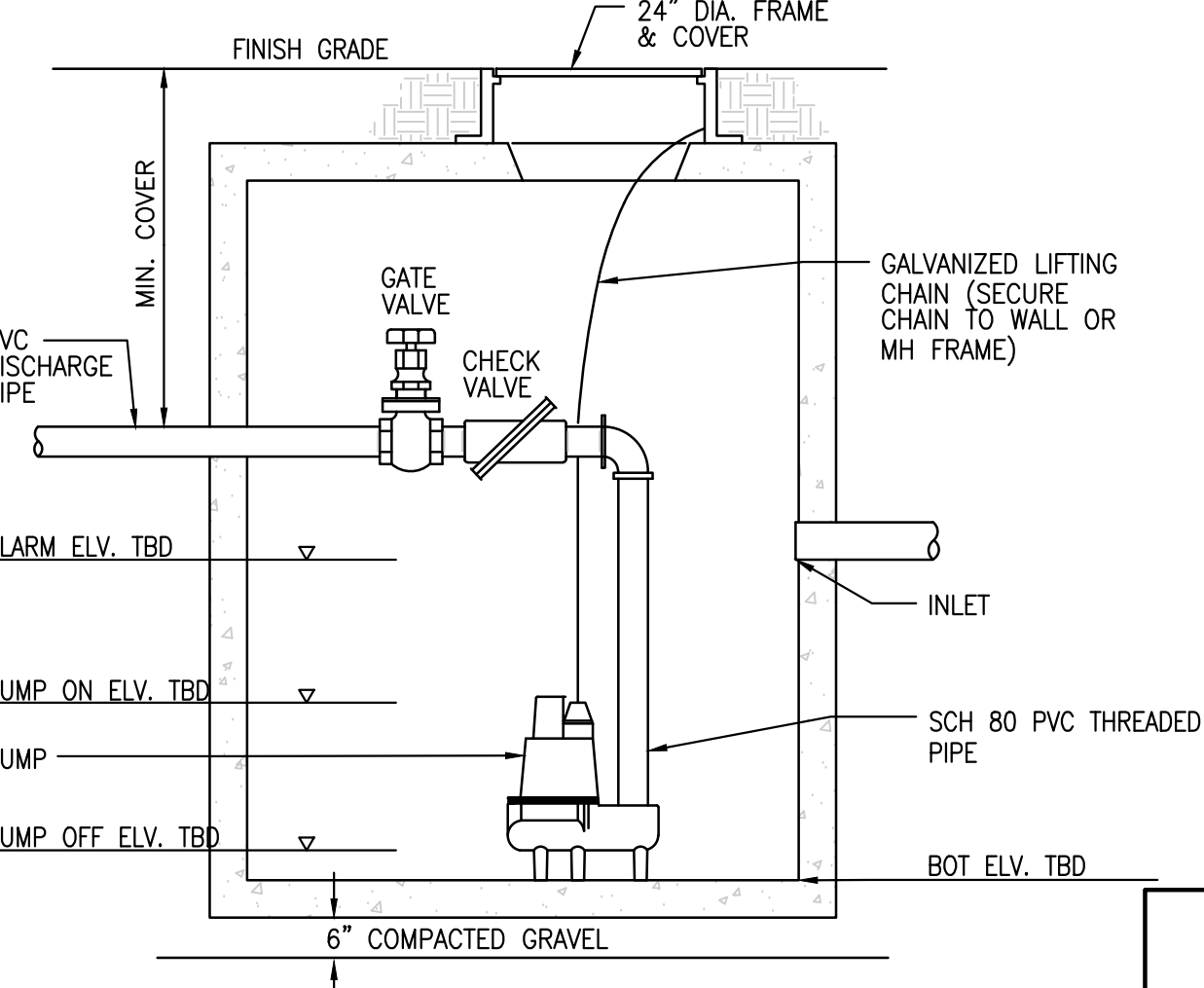

**PUMP CHAMBER**  
N.T.S.

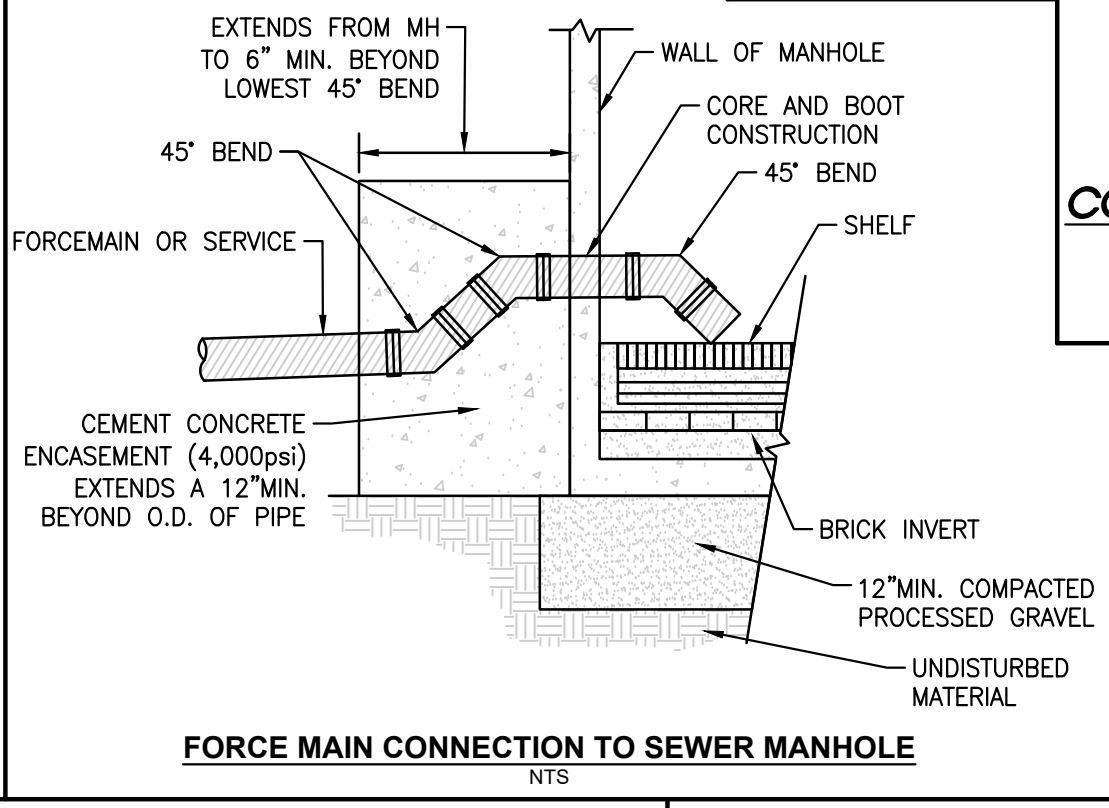

**FORCE MAIN CONNECTION TO SEWER MANHOLE**  
N.T.S.

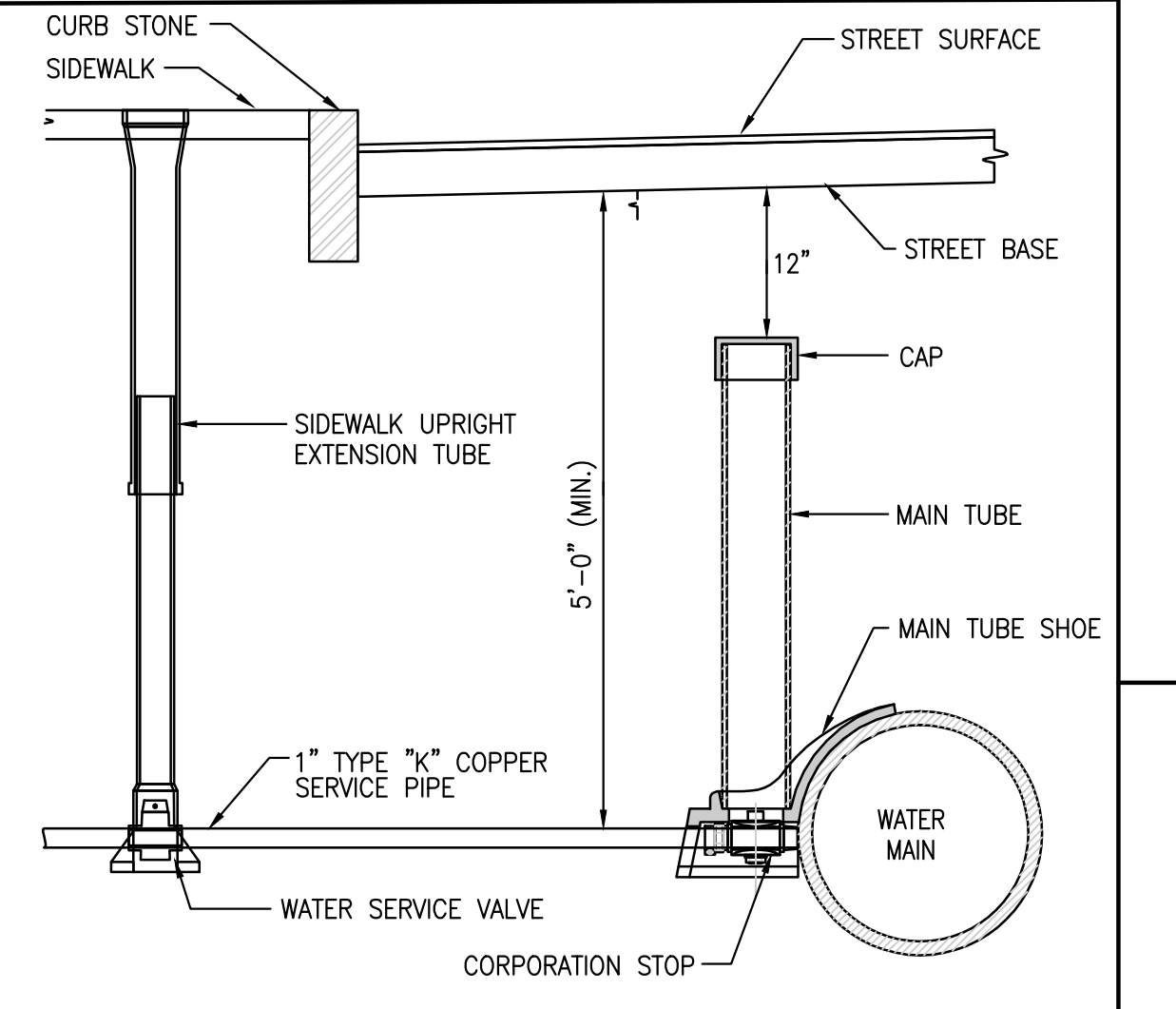

**TYPICAL WATER SERVICE CONNECTION**  
N.T.S.

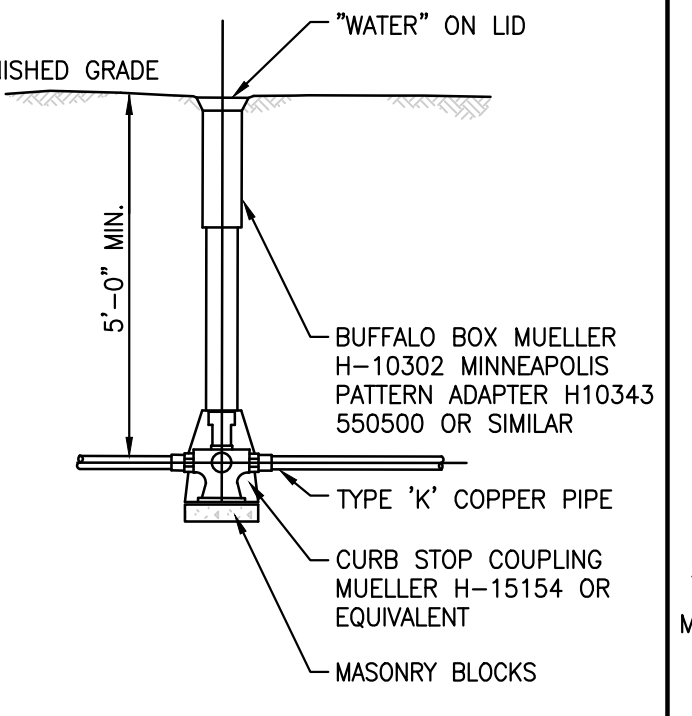

**WATER SERVICE VALVE**  
N.T.S.

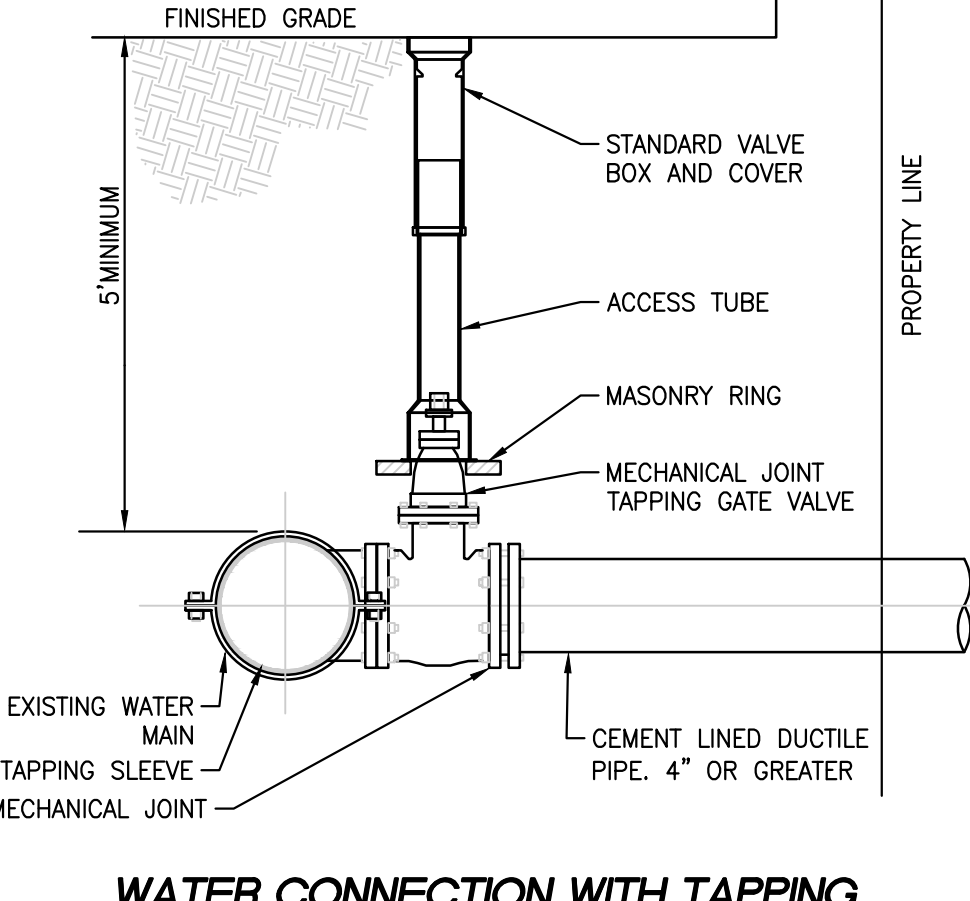

**WATER CONNECTION WITH TAPPING SLEEVE AND VALVE**  
N.T.S.

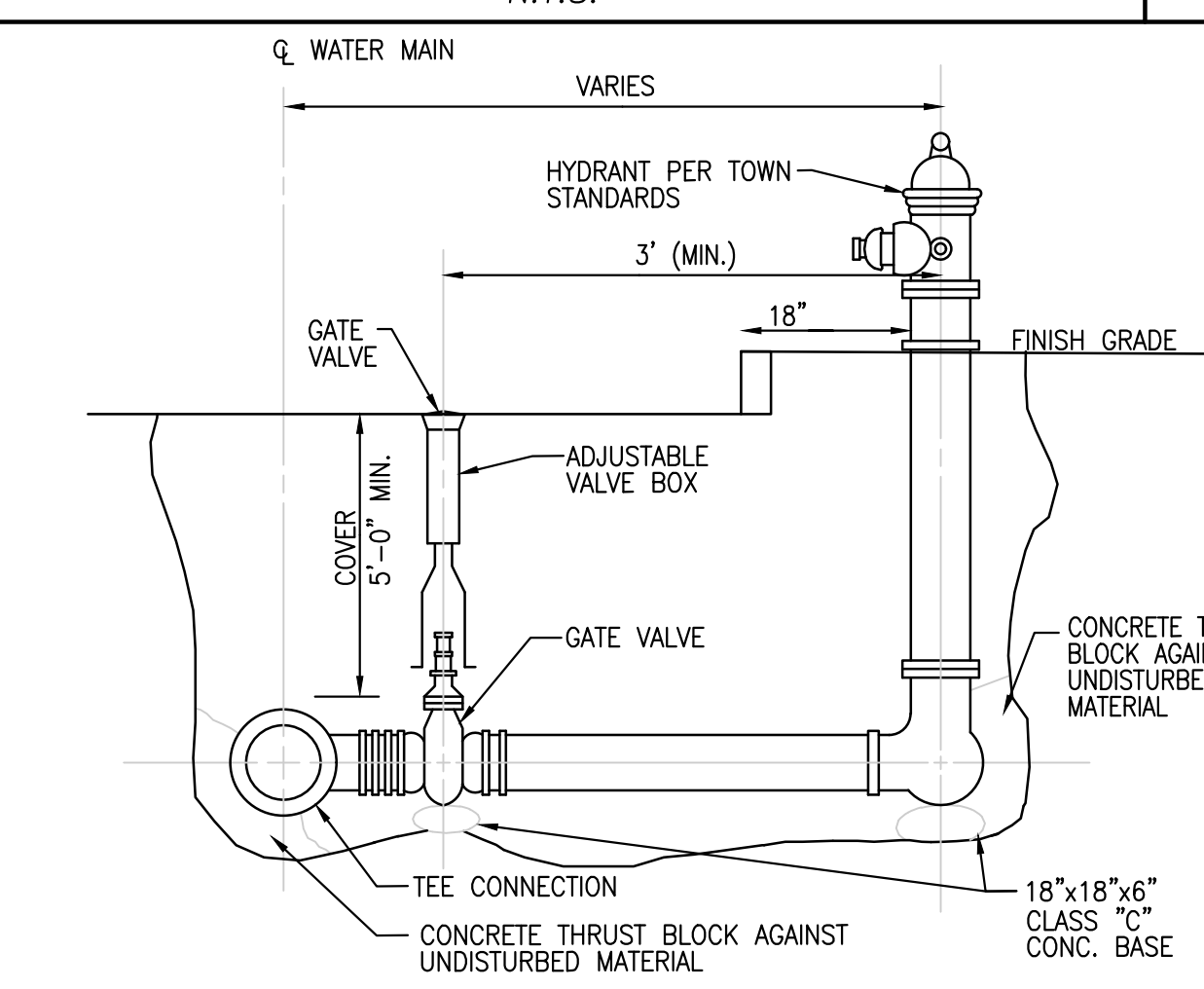

**PROPOSED FIRE HYDRANT**  
N.T.S.

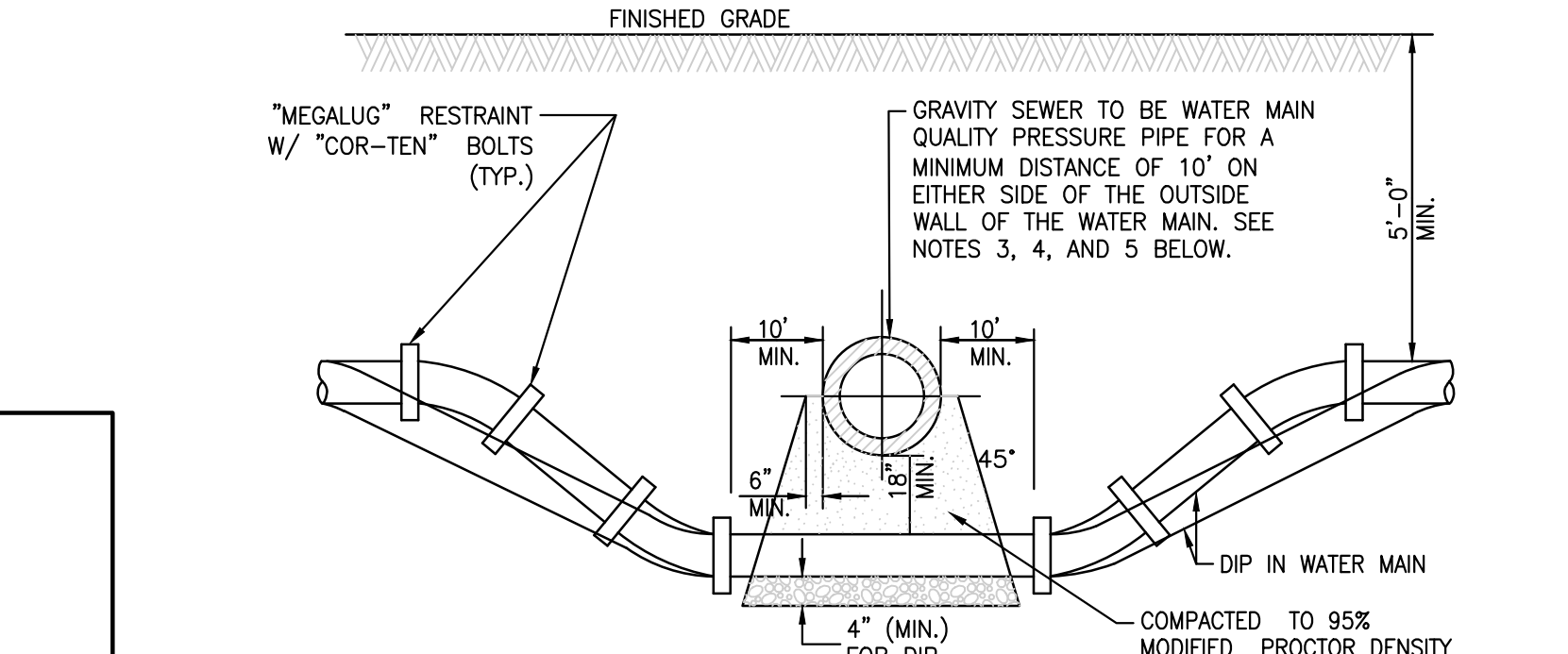

- NOTES:**
- HORIZONTAL AND VERTICAL SEPARATION BETWEEN WATERMAINS AND SEWERS SHALL COMPLY WITH APPLICABLE SECTIONS OF LOCAL OR STATE REQUIREMENTS, WHICHEVER IS MORE STRINGENT.
  - CONTRACTOR MAY BEND WATER MAIN PIPE UNIFORMLY UNDER SEWERS WITHOUT USING FITTINGS, PROVIDED THAT JOINT DEFLECTION DOES NOT EXCEED 5 DEGREES PER JOINT FOR PIPE UNDER 14" IN DIAMETER AND 3 DEGREES PER JOINT FOR PIPE 14" AND OVER IN DIAMETER. IF FITTINGS ARE USED, CONTINUOUS STRAPPING WITH RODS, STRAPS, NUTS AND BOLTS BELOW NORMAL WATERMAIN DEPTH ARE REQUIRED, OR RETAINER GLANDS MAY BE USED IN LIEU OF STRAPPING. RETAINER GLANDS TO BE CLOW No. F-1058 OR APPROVED EQUAL.
  - ALL SANITARY SEWER (INCLUDING SERVICE) CROSSINGS WHERE THE WATER MAINS OR WATER SERVICES ARE LESS THAN 18" VERTICALLY ABOVE THE SEWER SHALL BE POLYVINYL CHLORIDE PRESSURE PIPE (SDR 26-160 PSI) AND SHALL CONFORM WITH THE LATEST REVISION OF ASTM D- 2241. JOINTS SHALL CONFORM TO ASTM D-3139 AND ELASTOMERIC GASKETS SHALL CONFORM TO ASTM F-477. THE SAME PIPE AND JOINT MATERIALS SHALL BE USED WHENEVER WATER MAIN CROSSES BELOW THE SEWER.
  - ALL STORM SEWER (INCLUDING SERVICE) CROSSINGS WHERE THE WATER MAINS ARE LESS THAN 18" VERTICALLY ABOVE THE SEWER SHALL BE REINFORCED CONCRETE PIPE, ASTM C-361, CLASS D-25, WITH BELL AND SPIGOT JOINTS AND RUBBER GASKETS, OR PVC SDR 26 AS SPECIFIED IN NOTE 3 ABOVE. THE SAME PIPE AND JOINT MATERIAL SHALL BE USED WHENEVER WATER MAIN CROSSES BELOW THE SEWER.
  - FOR NEW SEWER INSTALLATIONS CROSSING OVER WATER MAINS, THE ENTIRE RUN OF NEW SEWER SHALL BE WATER MAIN QUALITY PIPE, EXTENDING FROM STRUCTURE TO STRUCTURE ON EACH SIDE OF THE CROSSING.

**WATER MAIN CROSSING**  
N.T.S.

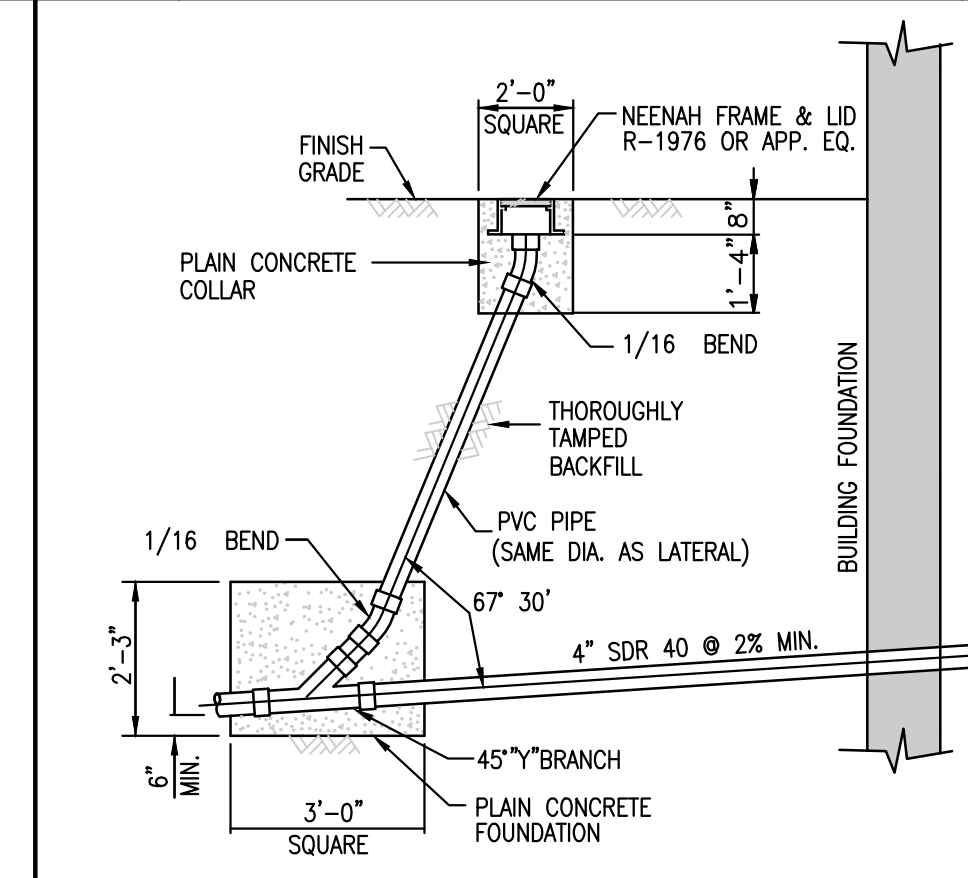

**SEWER SERVICE AT BUILDING W/ CLEANOUT**  
N.T.S.

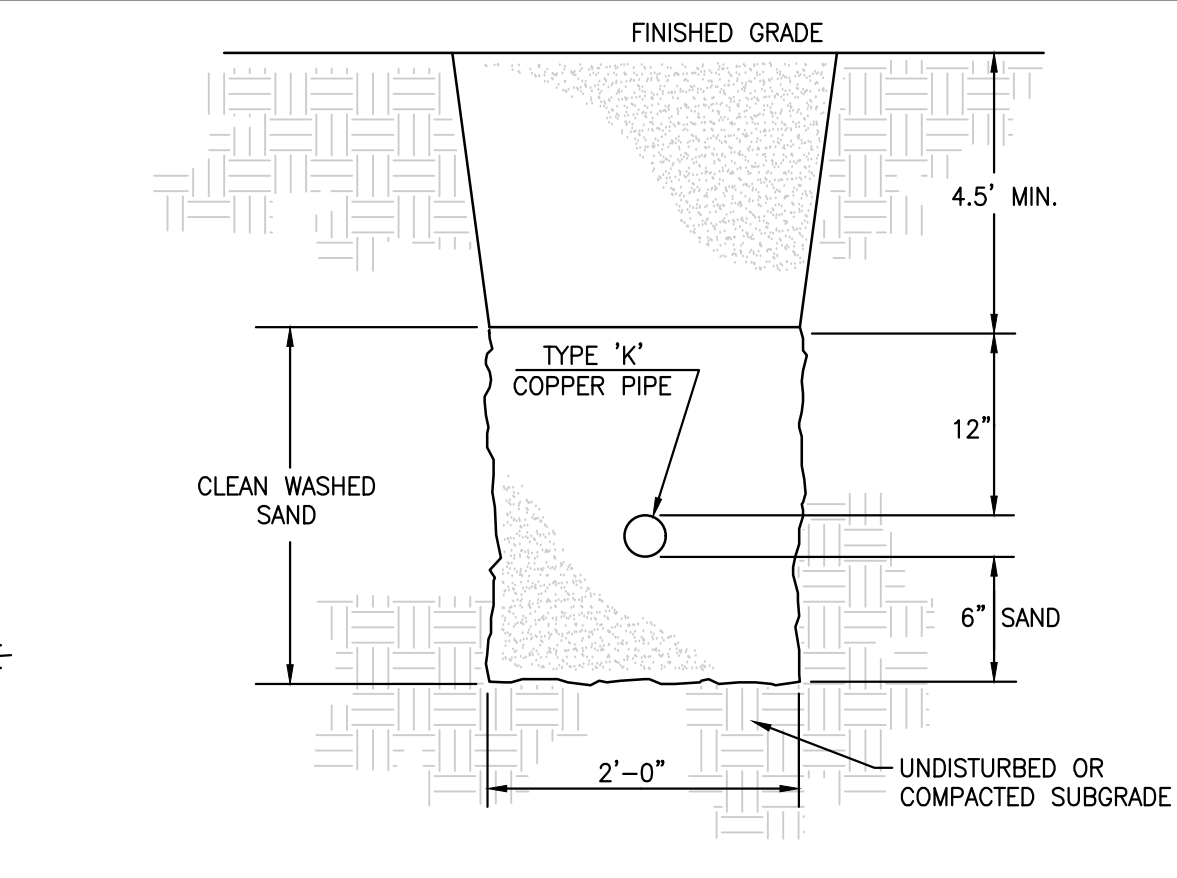

**COPPER WATER SERVICE PIPE TRENCH**  
N.T.S.

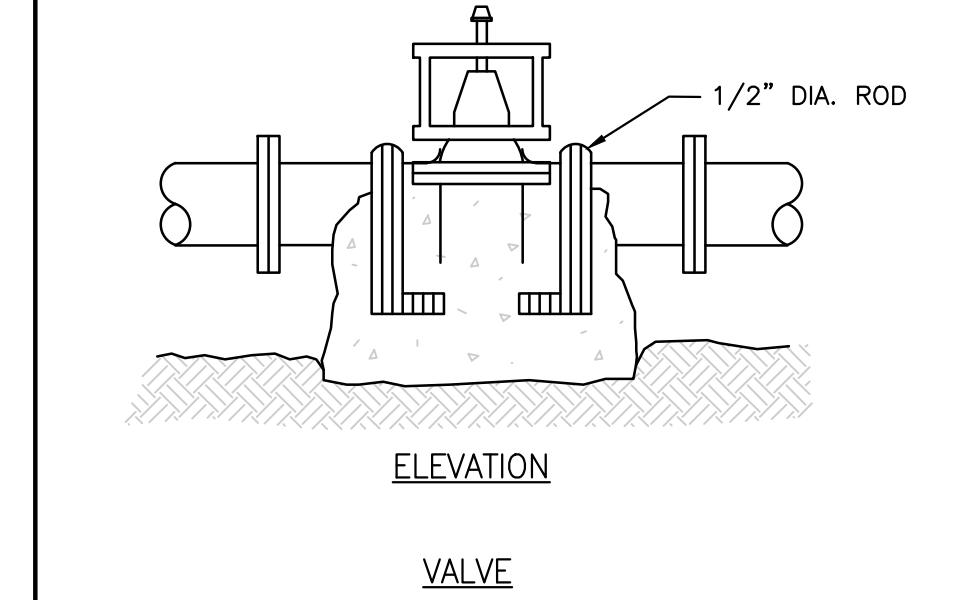
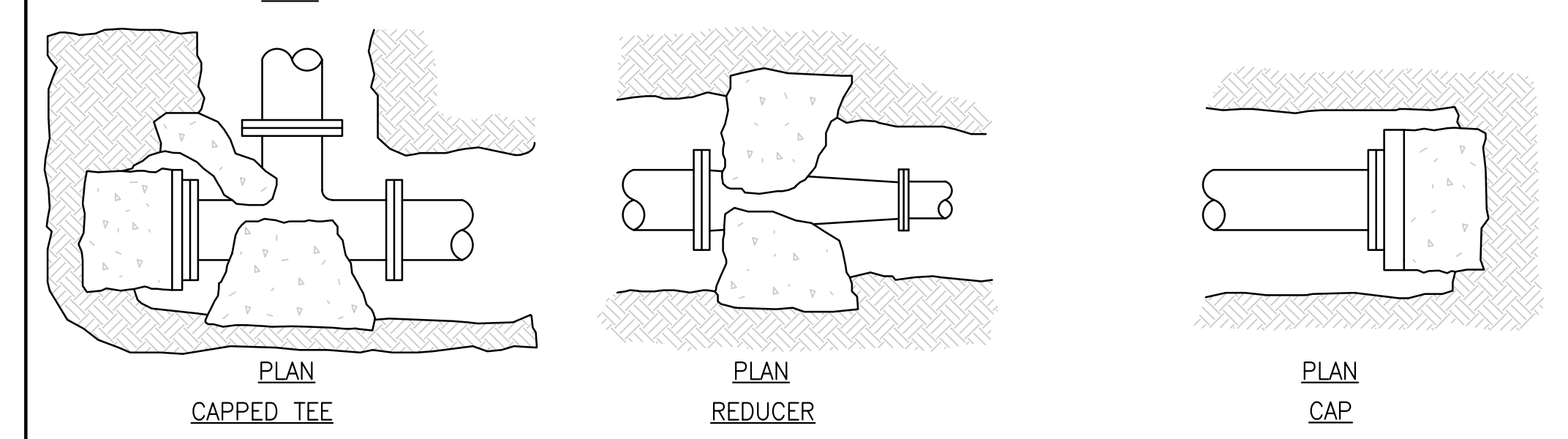
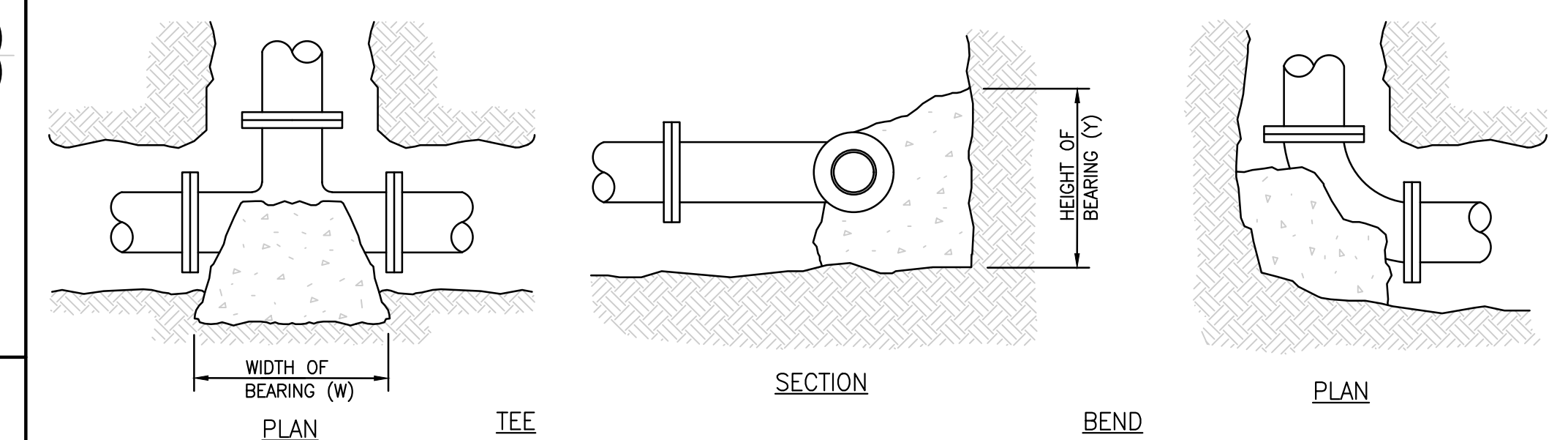

**THRUST BLOCKS FOR WATER SYSTEM**  
N.T.S.

PIPE SIZE	WATER PIPE	
	TEE, DEAD END, 90° BEND	45° & 22-8° BENDS
4" OR LESS	3 SQ. FEET	3 SQ. FEET
6"	4 SQ. FEET	3 SQ. FEET
8"	6 SQ. FEET	3 SQ. FEET
10"	9 SQ. FEET	5 SQ. FEET
12"	13 SQ. FEET	7 SQ. FEET
16"	23 SQ. FEET	12 SQ. FEET

- NOTES:**
- THRUST BLOCKS TO EXTEND TO UNDISTURBED GROUND.
  - ALL CONCRETE SHALL BE CLASS B.
  - TABLE IS BASED ON 3000 LB./SQ. FT. SOIL. IF SOIL CONDITIONS ARE FOUND TO INDICATE SOIL BEARING LESS, THE AREAS SHALL BE INCREASED ACCORDINGLY.
  - AREAS FOR PIPES GREATER THAN 16" SHALL BE CALCULATED FOR EACH PROJECT.
  - FOR ALL NON BEARING VERTICAL SURFACES.

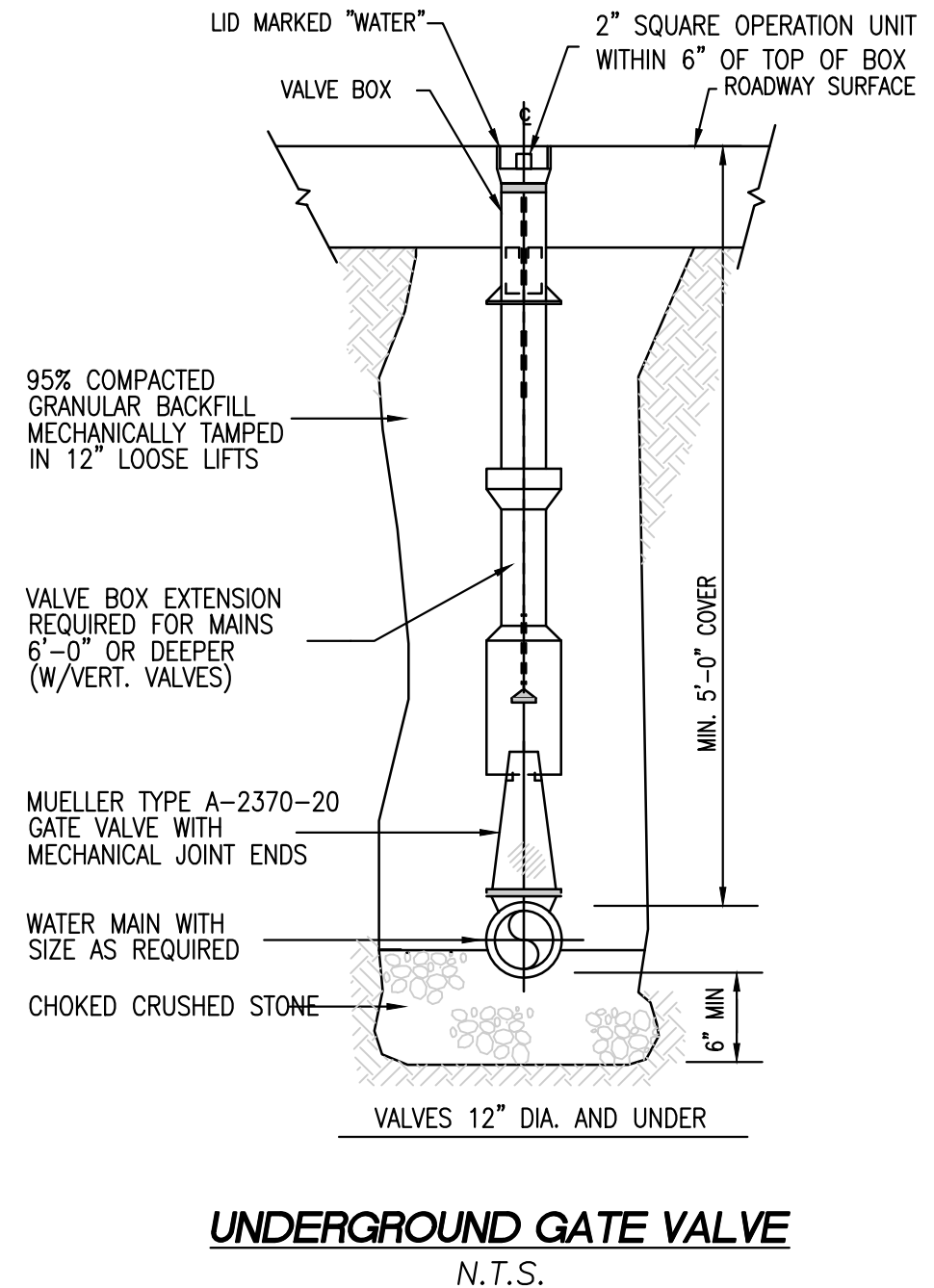

**UNDERGROUND GATE VALVE**  
N.T.S.

**TOWN OF READING**  
COMMUNITY PLANNING & DEVELOPMENT COMMISSION  
DATE: \_\_\_\_\_

FOR REGISTRY USE ONLY

**ENGINEER:**  
**FODERA**  
ENGINEERING

**SURVEYOR:**  
**PFS Land**  
Surveying, Inc.

(617)877-3293  
gfodera@foderaengineering.com  
28 Harbor St., Suite 204  
Danvers, MA 01923  
www.fodera.com

20 Bulch Avenue  
Groveland, MA 01834  
P.978.891.5203  
www.pfsland.com

**COPYRIGHT NOTICE**  
This drawing is property of Fodera Engineering and is not to be used for any purpose other than the specific project and site named herein, and cannot be reproduced in any manner without the express written permission from the Firm's Principal.

**JOB NO.:** 20160-149  
**SHEET TITLE:**  
DETAILS  
SHEET 1  
**SHEET NUMBER:**  
C-6

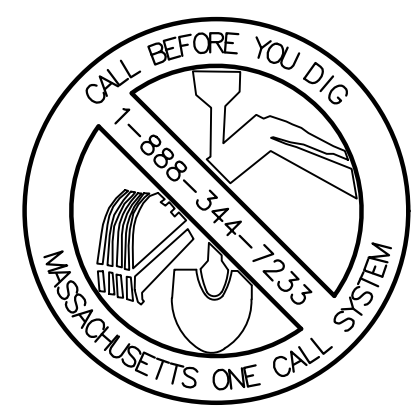

REVISION	DATE	BY
REVISION 1	6/20/23	GGF

**PROJECT LOCATION:**  
LOTS 2, 3, & 4  
GRANDVIEW ROAD  
READING, MA 01867

**PARCEL ID:**  
MAP 27, LOT 404

**PLAN SET:**  
MAJOR SITE PLAN MODIFICATION  
GRANDVIEW ROAD SUBDIVISION - PRIVATE WAY  
(GRANDVIEW ROAD EXTENSION)

APRIL 20, 2023  
SCALE: N.T.S.

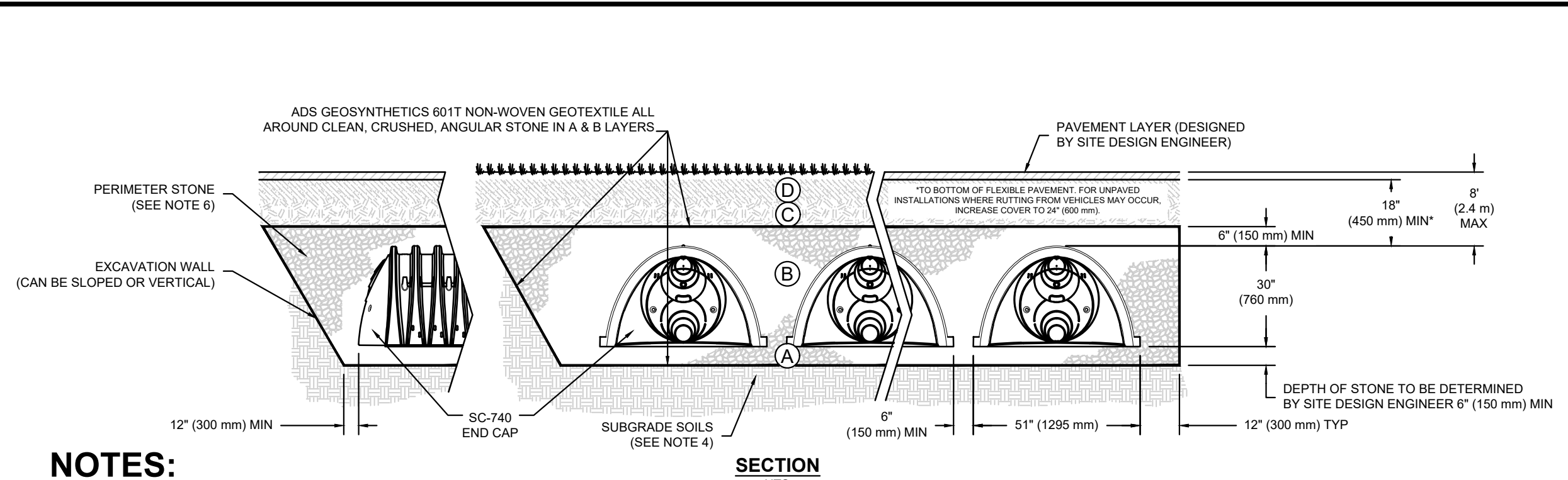
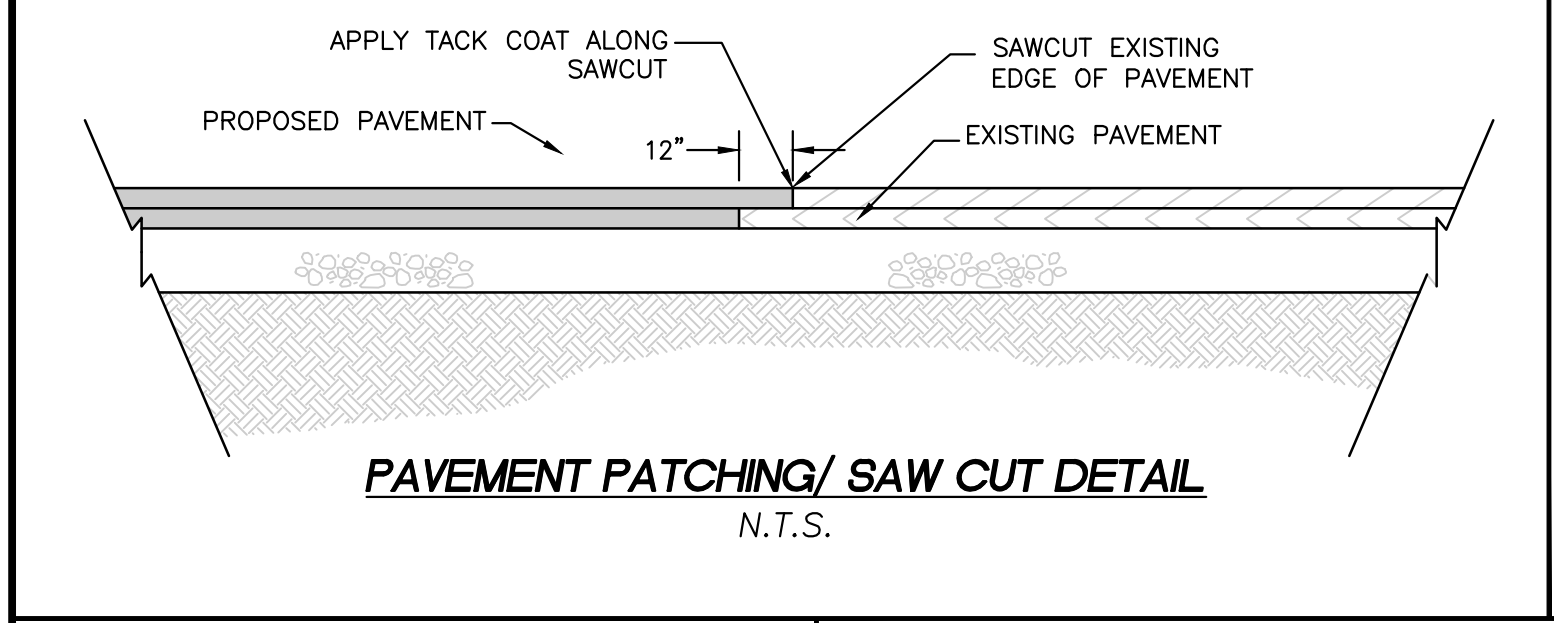
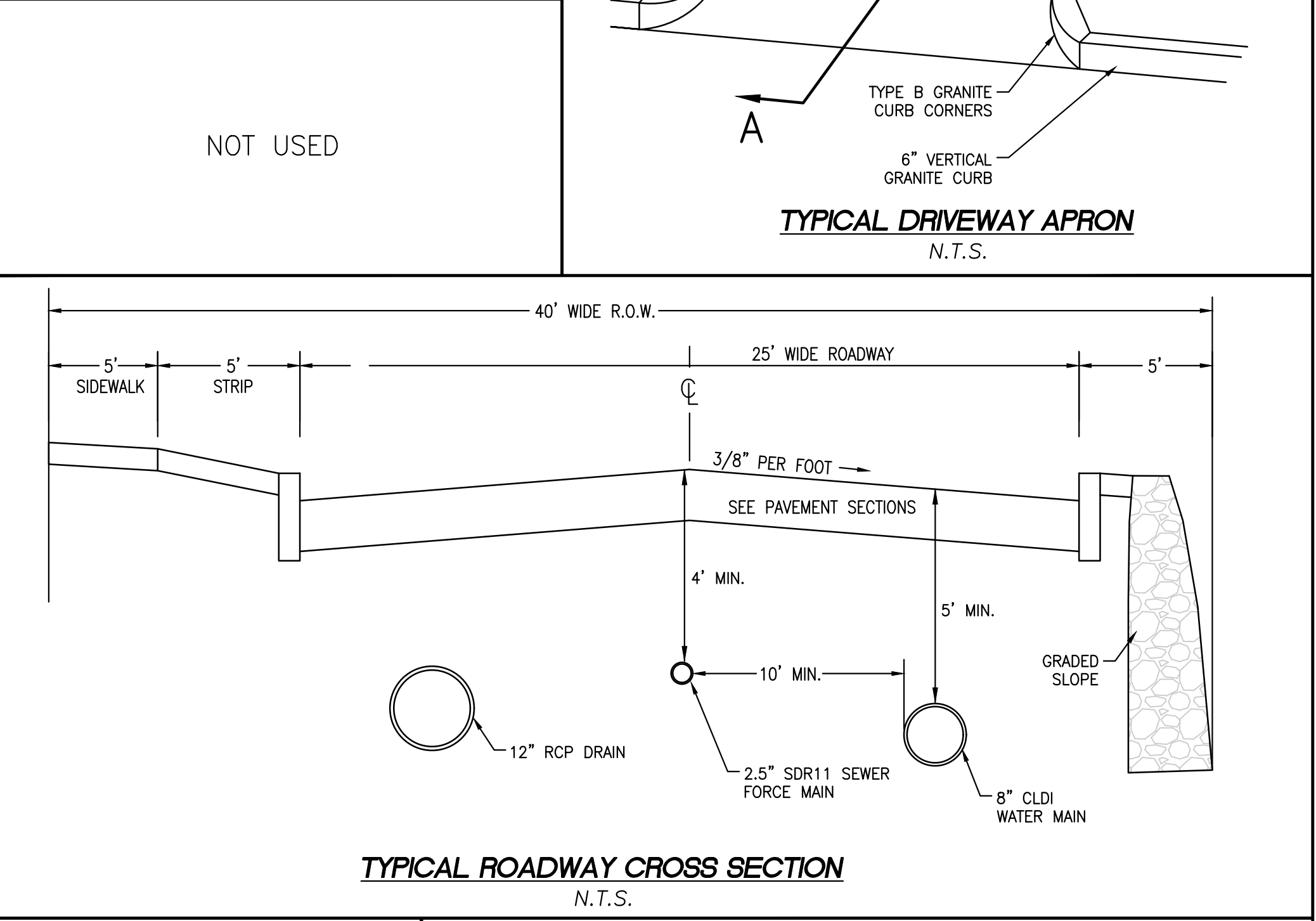
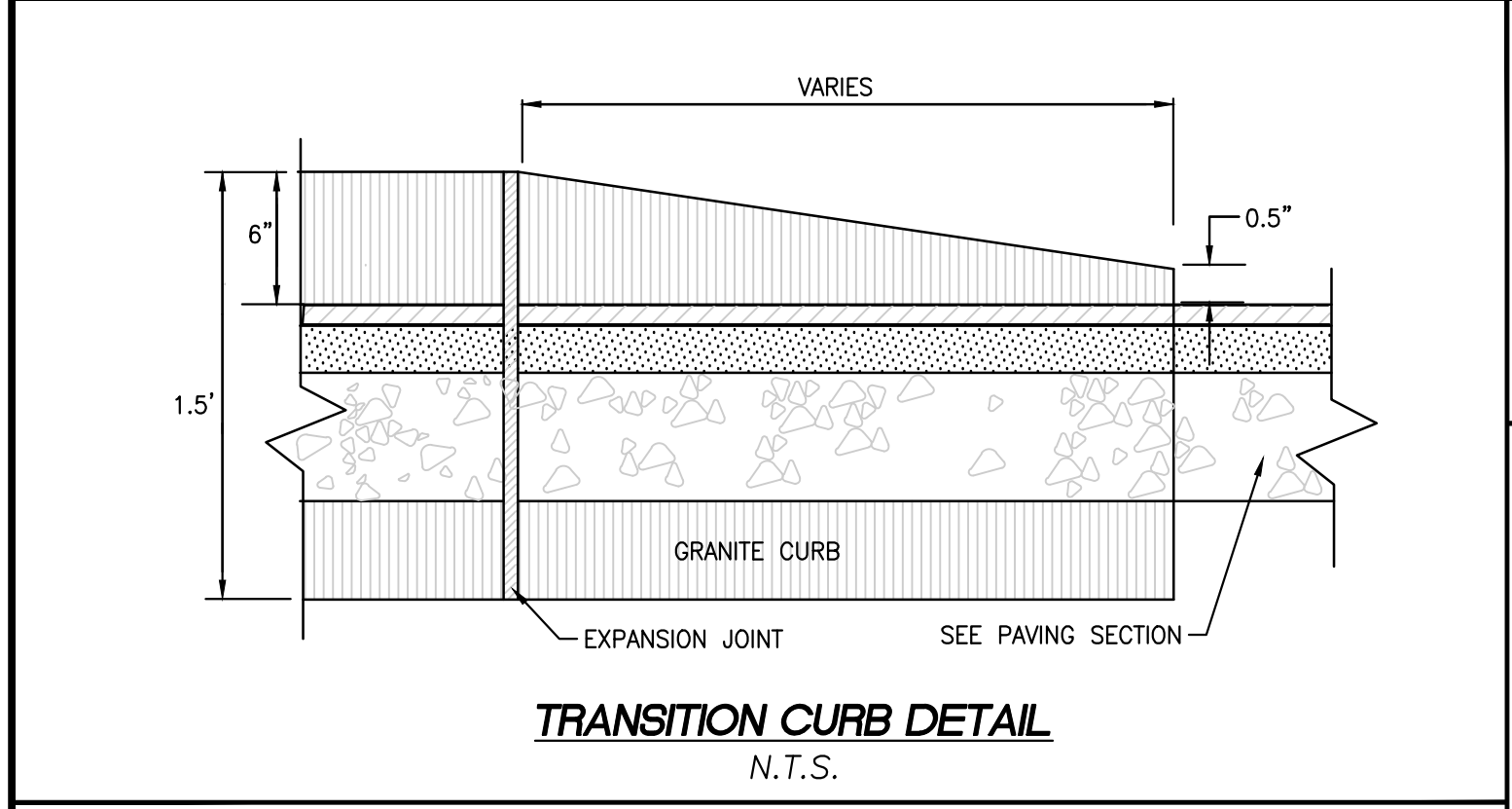
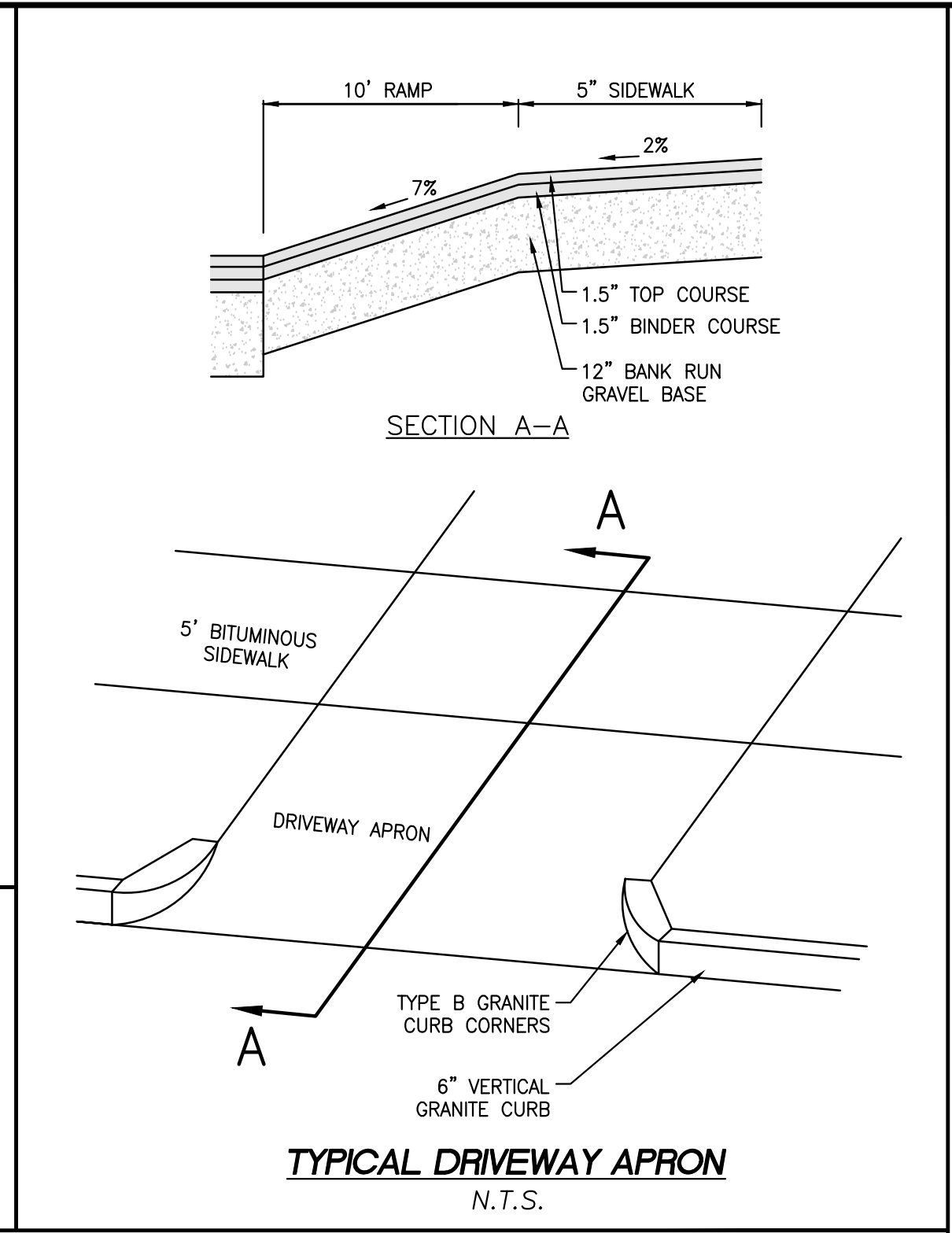
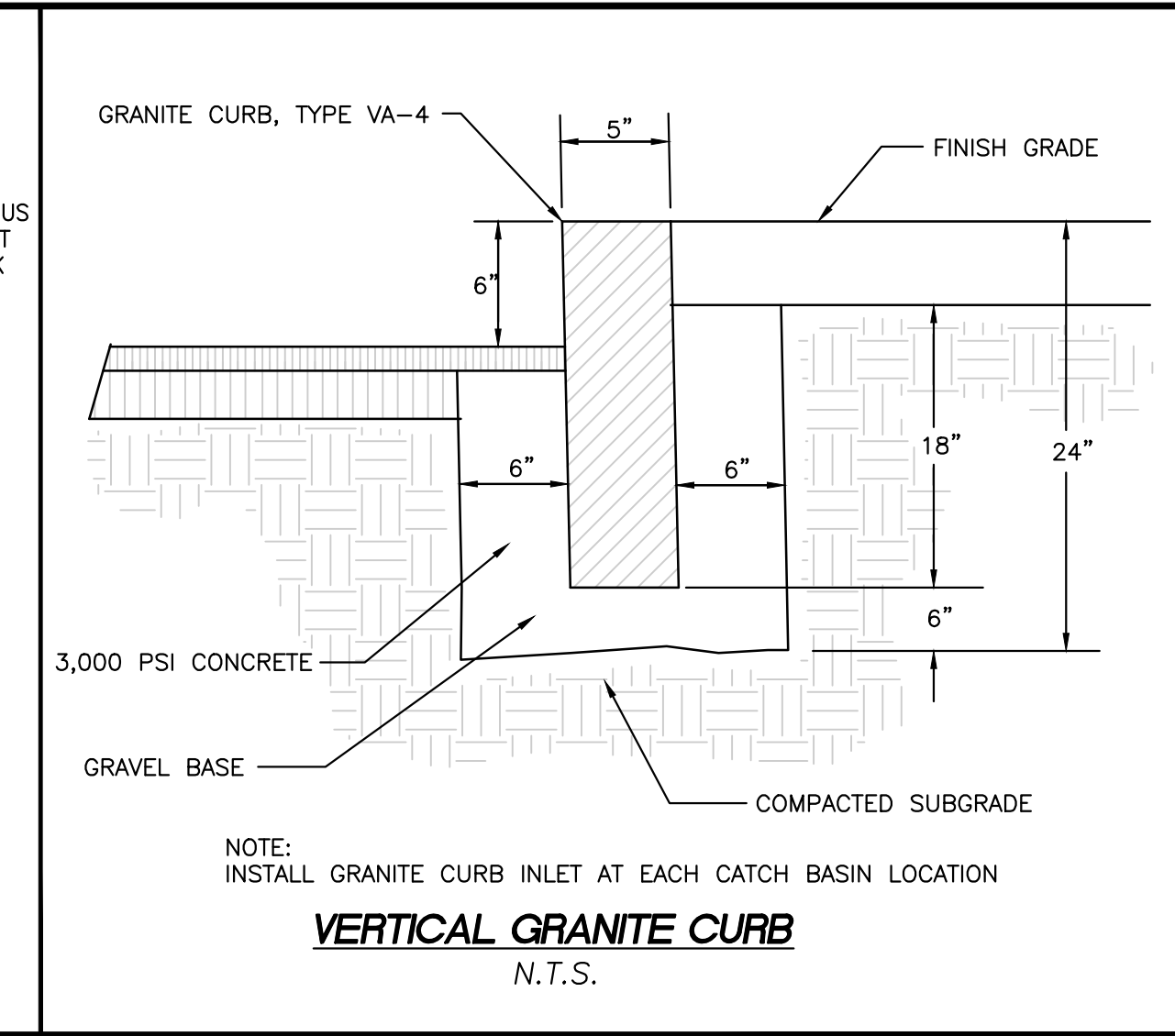
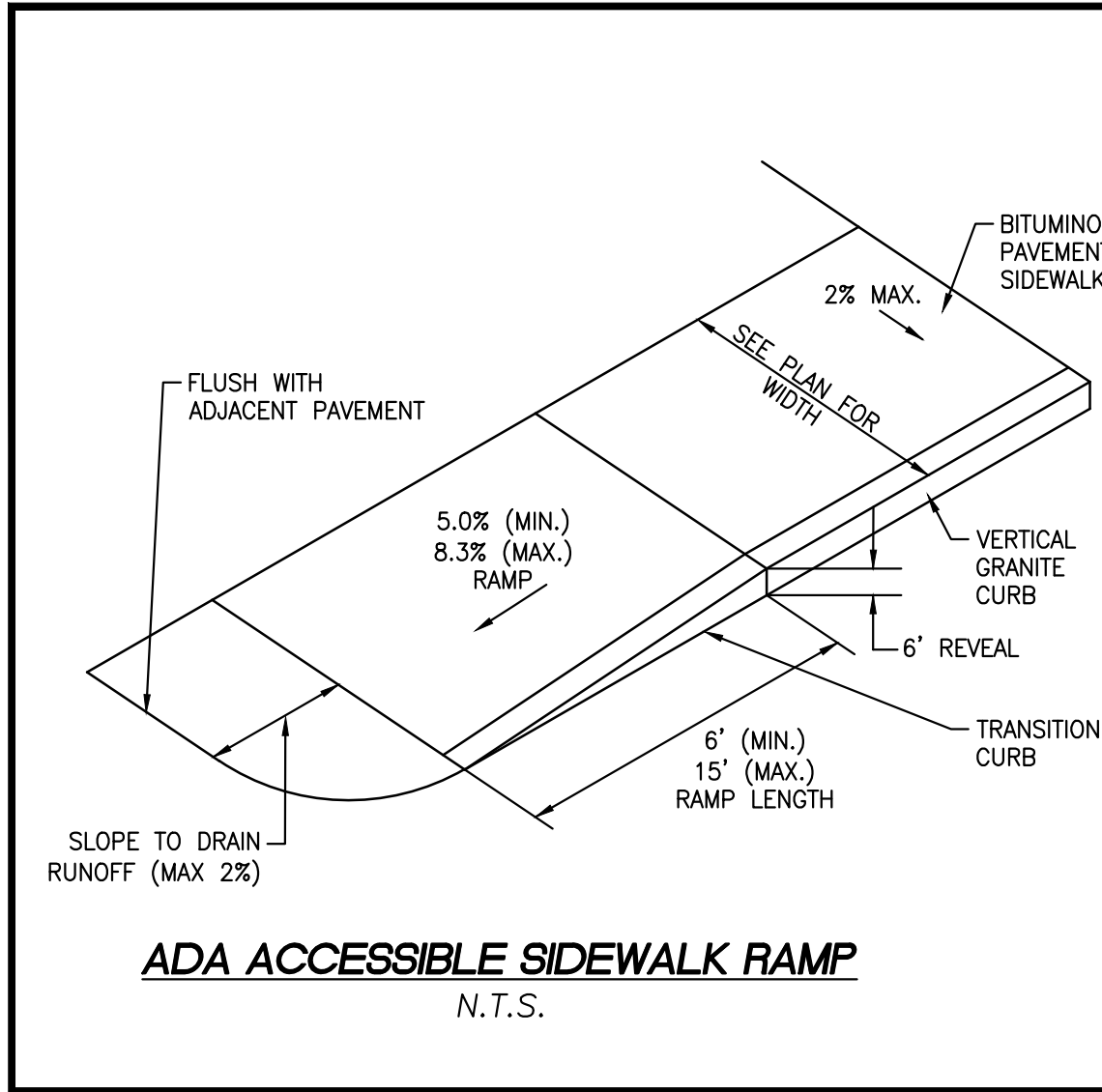

- NOTES:**
- SC-740 CHAMBERS SHALL BE DESIGNED IN ACCORDANCE WITH ASTM F2787 "STANDARD PRACTICE FOR STRUCTURAL DESIGN OF THERMOPLASTIC CORRUGATED WALL STORMWATER COLLECTION CHAMBERS".
  - "ACCEPTABLE FILL MATERIALS" TABLE ABOVE PROVIDES MATERIAL LOCATIONS, DESCRIPTIONS, GRADATIONS, AND COMPACTION REQUIREMENTS FOR FOUNDATION, EMBEDMENT, AND FILL MATERIALS.
  - THE SITE DESIGN ENGINEER IS RESPONSIBLE FOR ASSESSING THE BEARING RESISTANCE (ALLOWABLE BEARING CAPACITY) OF THE SUBGRADE SOILS AND THE DEPTH OF FOUNDATION STONE WITH CONSIDERATION FOR THE RANGE OF EXPECTED SOIL MOISTURE CONDITIONS.
  - PERIMETER STONE MUST BE EXTENDED HORIZONTALLY TO THE EXCAVATION WALL FOR BOTH VERTICAL AND SLOPED EXCAVATION WALLS.
  - ONCE LAYER 'C' IS PLACED, ANY SOIL/MATERIAL CAN BE PLACED IN LAYER 'D' UP TO THE FINISHED GRADE. MOST PAVEMENT SUBBASE SOILS CAN BE USED TO REPLACE THE MATERIAL REQUIREMENTS OF LAYER 'C' OR 'D' AT THE SITE DESIGN ENGINEER'S DISCRETION.

- (A) DOUBLE WASHED 3/4"-1 1/2" STONE
- (B) DOUBLE WASHED 3/4"-1 1/2" STONE
- (C) CLEAN GRANULAR FILL MATERIAL
- (D) 4"-6" TOPSOIL (LAWN AREA) OR 12" COMPACTED GRAVEL BASE (PAVEMENT AREA)

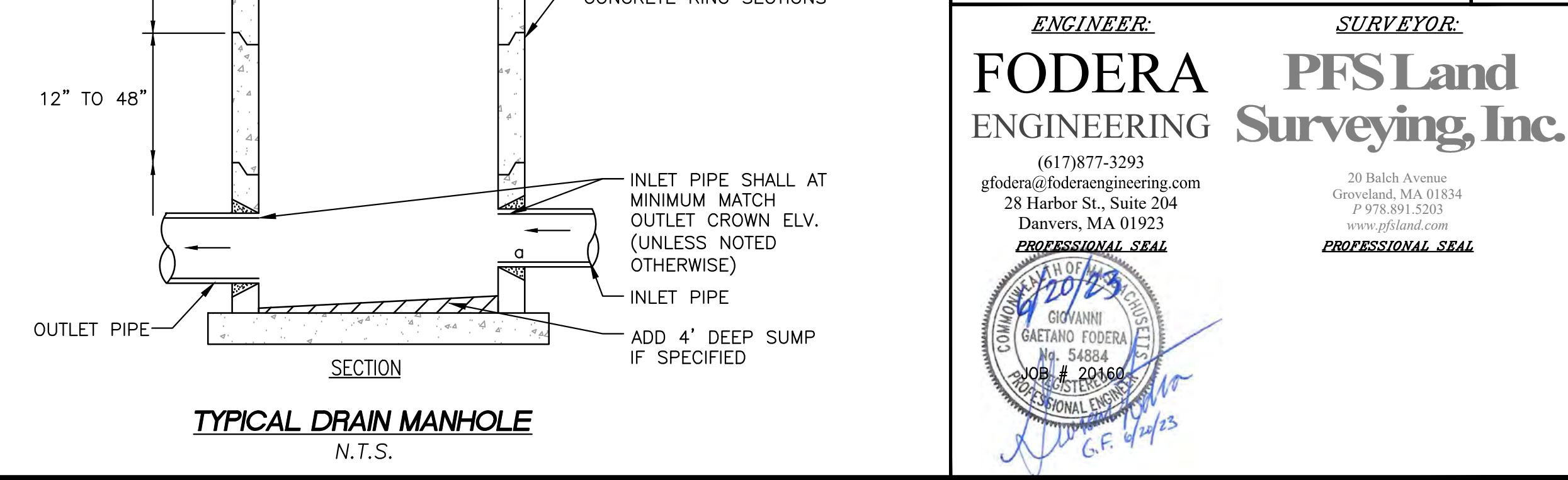
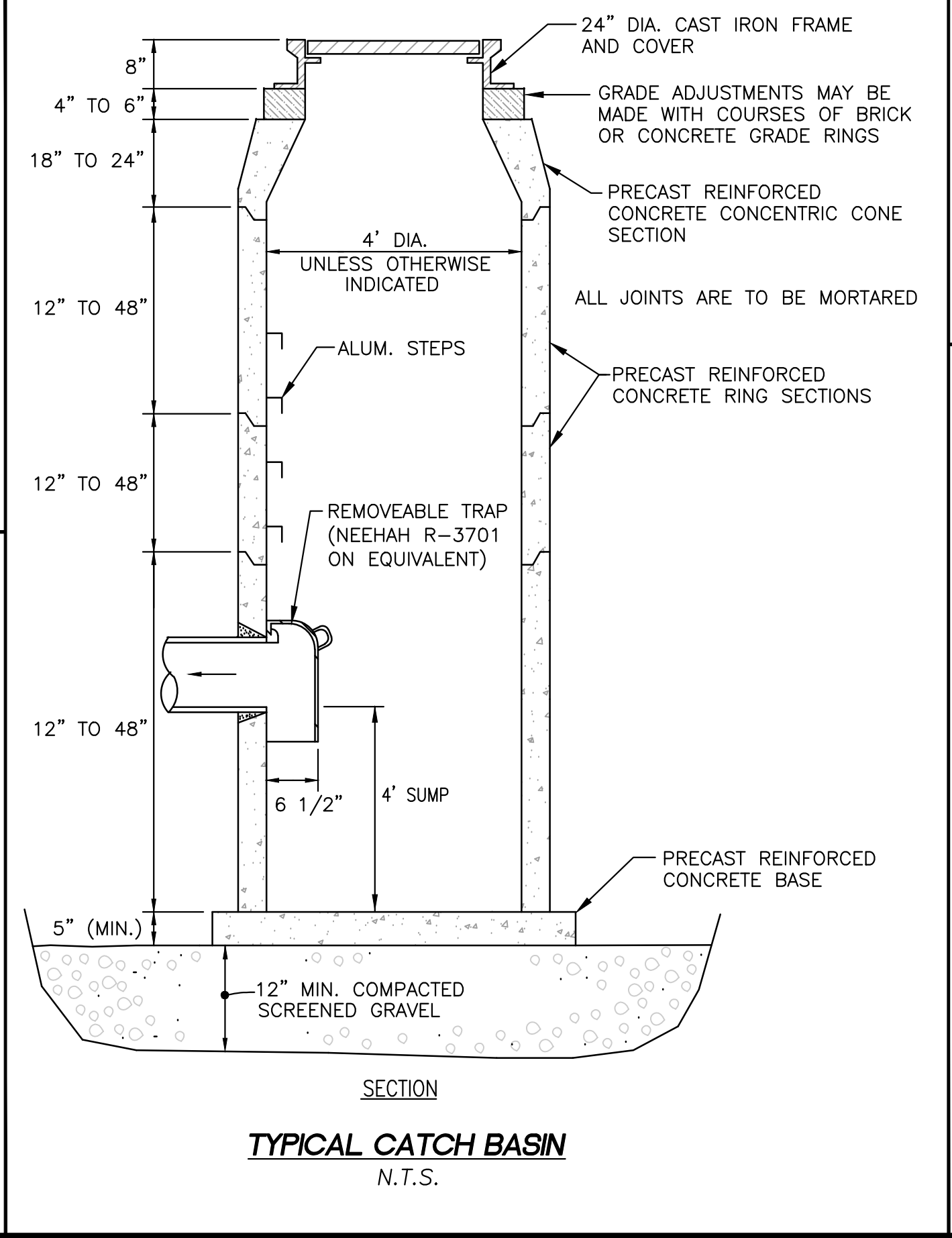
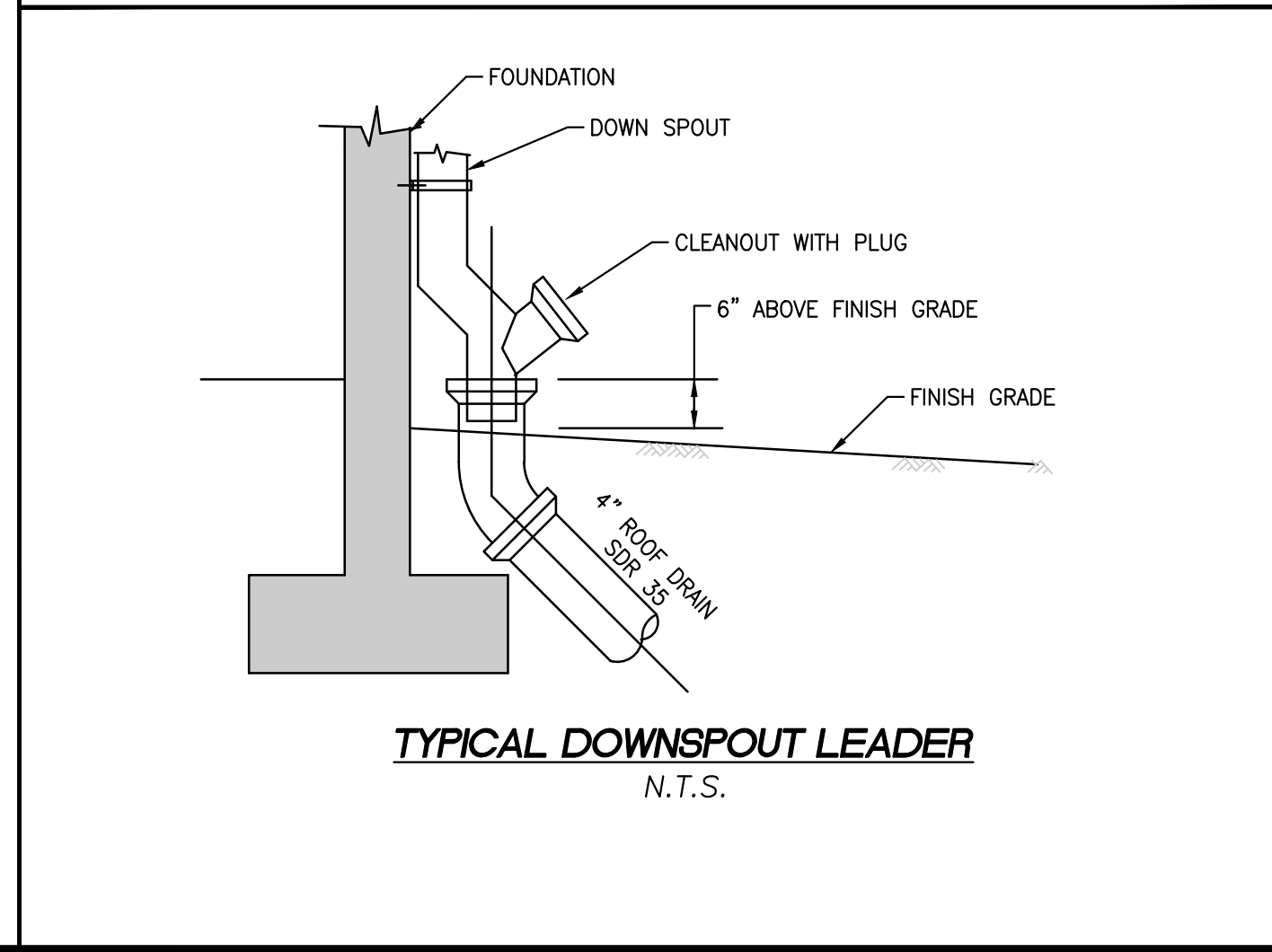
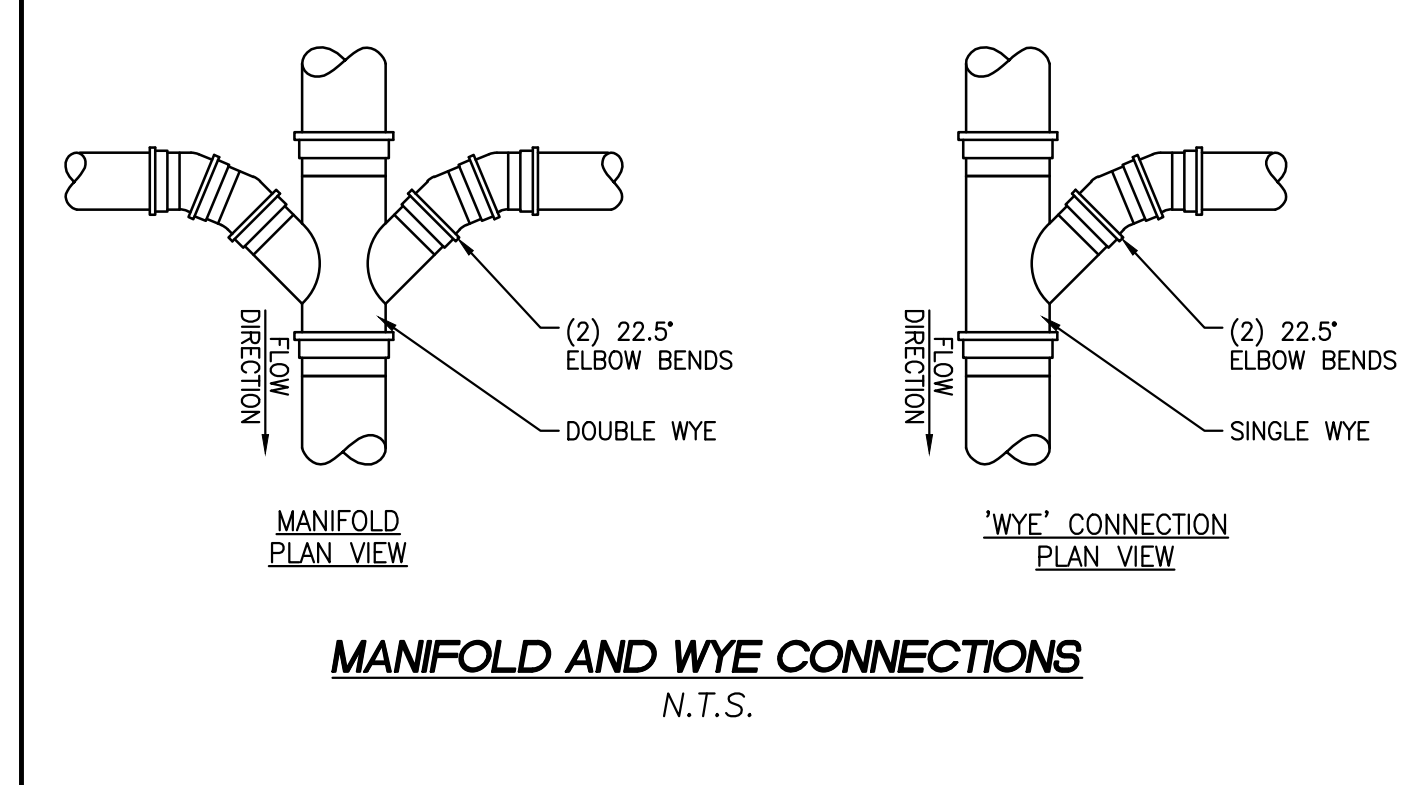
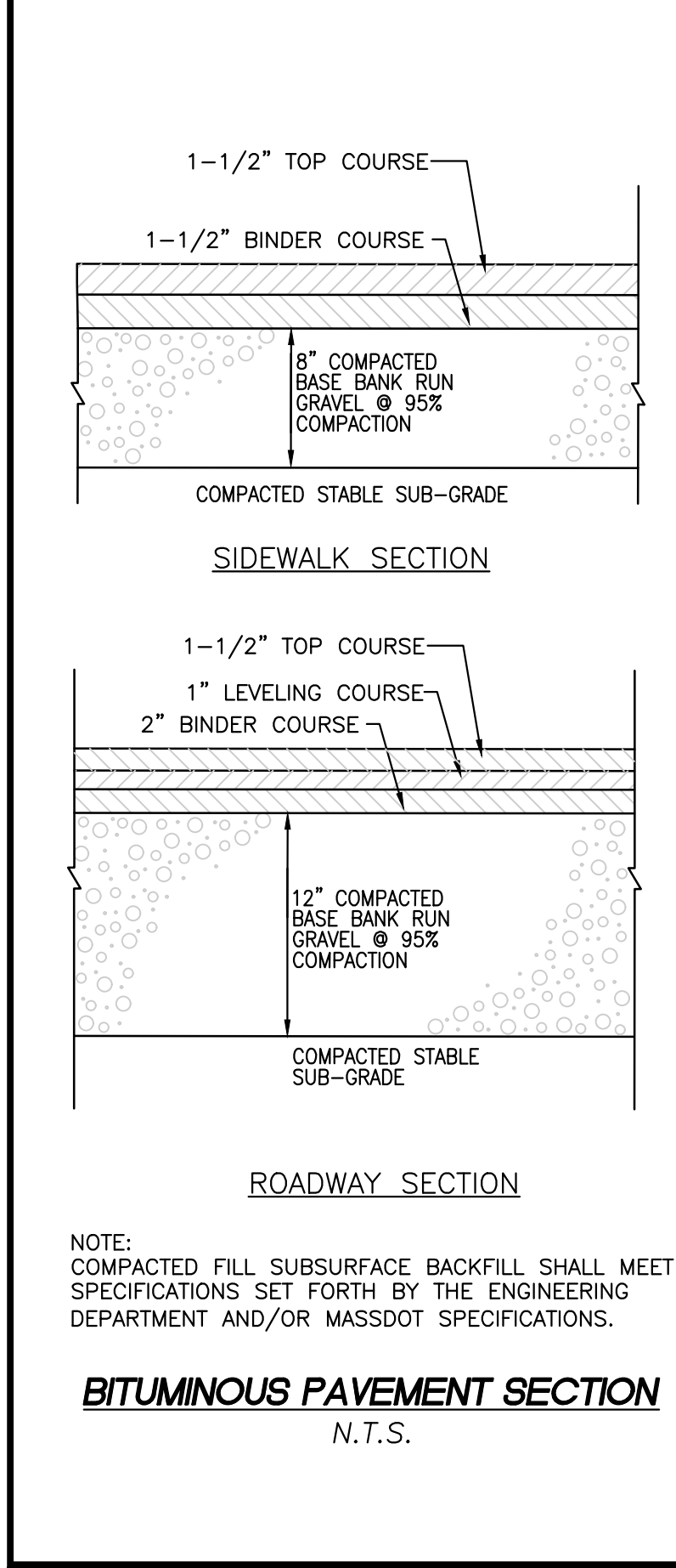
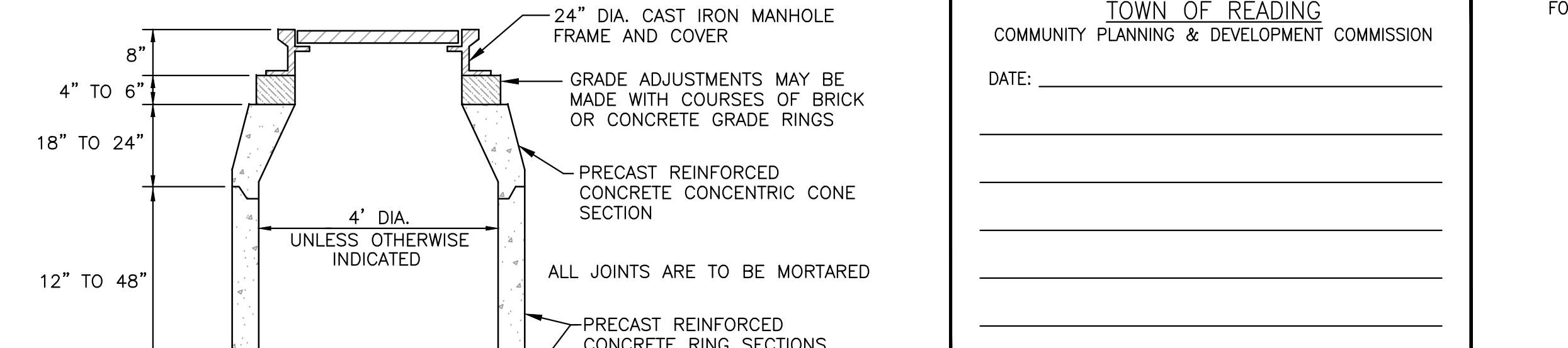
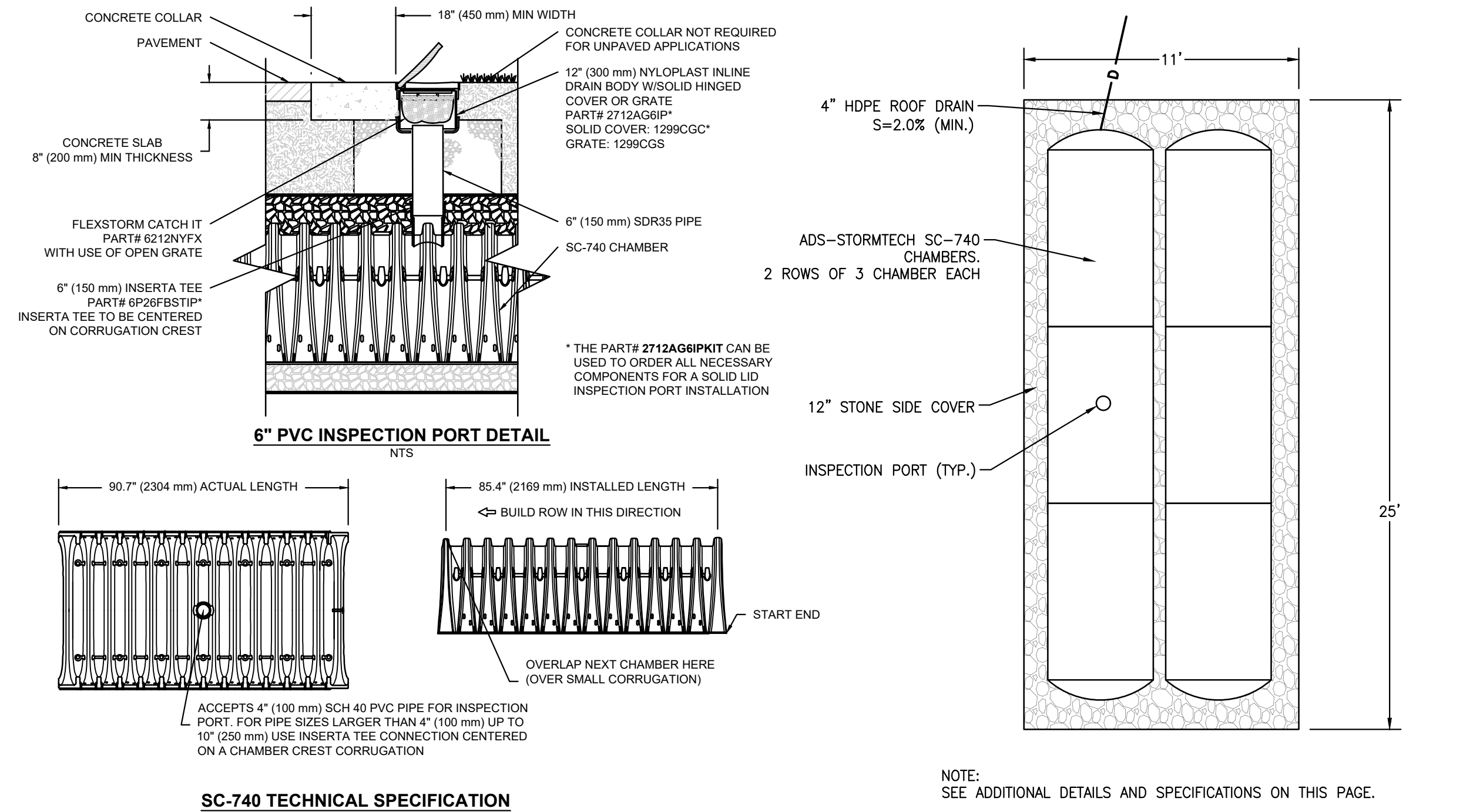

REVISION	DATE	BY
REVISION 1	6/20/23	GGF

**PROJECT LOCATION:**  
LOTS 2, 3, & 4  
GRANDVIEW ROAD  
READING, MA 01867

**PARCEL ID:**  
MAP 27, LOT 404

**PLAN SET:**  
MAJOR SITE PLAN MODIFICATION  
GRANDVIEW ROAD SUBDIVISION - PRIVATE WAY  
(GRANDVIEW ROAD EXTENSION)

APRIL 20, 2023  
SCALE: N.T.S.

**TOWN OF READING**  
COMMUNITY PLANNING & DEVELOPMENT COMMISSION

DATE: \_\_\_\_\_

**ENGINEER:**  
**FODERA ENGINEERING**  
(617)877-3293  
gfodera@foderaengineering.com  
28 Harbor St., Suite 204  
Danvers, MA 01923  
PROFESSIONAL SEAL

**SURVEYOR:**  
**PFS Land Surveying, Inc.**  
30 Bulch Avenue  
Groveland, MA 01834  
P.978.891.5203  
www.pfsland.com  
PROFESSIONAL SEAL

**PROFESSIONAL SEAL:**  
GIOVANNI FODERA  
No. 54844  
JOB # 20160  
APRIL 20, 2023

**COPYRIGHT NOTICE:**  
This drawing is property of Fodera Engineering and is not to be used for any purpose other than the specific project and site named herein, and cannot be reproduced in any manner without the express written permission from the Firm's Principal.

**JOB NO.:** 20160-149  
**SHEET TITLE:** DETAILS  
**SHEET 2**  
**SHEET NUMBER:** C-7



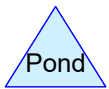
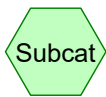
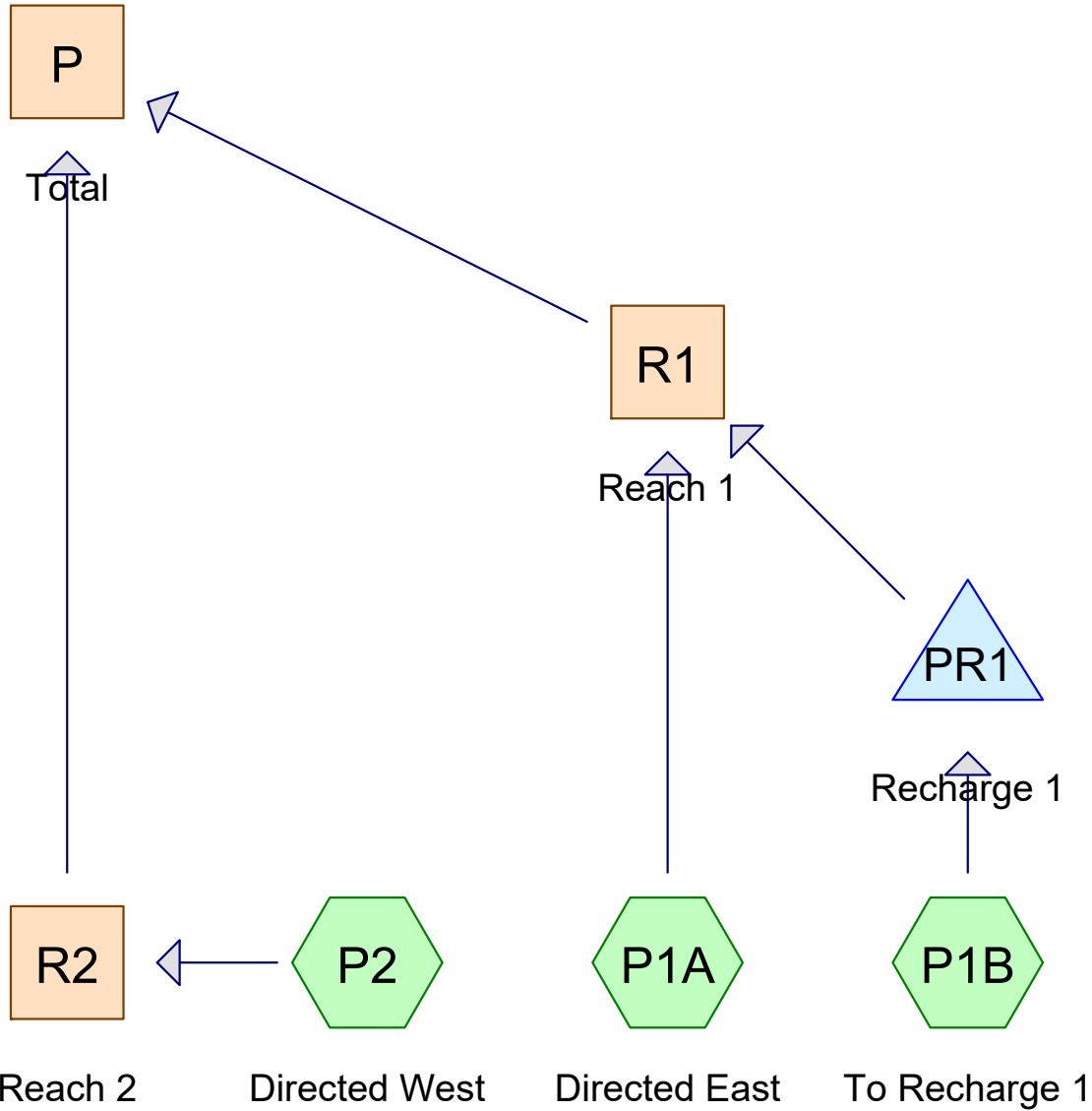

**Routing Diagram for 2023-03-10\_POST-DRAINAGE**  
 Prepared by {enter your company name here}, Printed 6/20/2023  
 HydroCAD® 10.10-3a s/n 11112 © 2020 HydroCAD Software Solutions LLC

**2023-03-10\_POST-DRAINAGE**

Prepared by {enter your company name here}

HydroCAD® 10.10-3a s/n 11112 © 2020 HydroCAD Software Solutions LLC

Post Construction Runoff  
Type III 24-hr 2-Year Rainfall=3.31"

Printed 6/20/2023

Page 2

**Summary for Subcatchment P1A: Directed East**

Runoff = 0.01 cfs @ 13.79 hrs, Volume= 0.008 af, Depth> 0.11"

Runoff by SCS TR-20 method, UH=SCS, Weighted-CN, Time Span= 0.00-24.00 hrs, dt= 0.01 hrs  
Type III 24-hr 2-Year Rainfall=3.31"

Area (sf)	CN	Description
* 3,060	98	Impervious
14,250	39	>75% Grass cover, Good, HSG A
11,924	30	Woods, Good, HSG A
4,950	74	>75% Grass cover, Good, HSG C
109	70	Woods, Good, HSG C
2,333	80	>75% Grass cover, Good, HSG D
36,626	48	Weighted Average
33,566		91.65% Pervious Area
3,060		8.35% Impervious Area

Tc (min)	Length (feet)	Slope (ft/ft)	Velocity (ft/sec)	Capacity (cfs)	Description
10.0	50	0.1400	0.08		<b>Sheet Flow, Sheet Flow Woods</b> Woods: Dense underbrush n= 0.800 P2= 3.10"
0.8	75	0.1067	1.63		<b>Shallow Concentrated Flow, Concentrated Woods</b> Woodland Kv= 5.0 fps
10.8	125	Total			

**Subcatchment P1A: Directed East**

Hydrograph

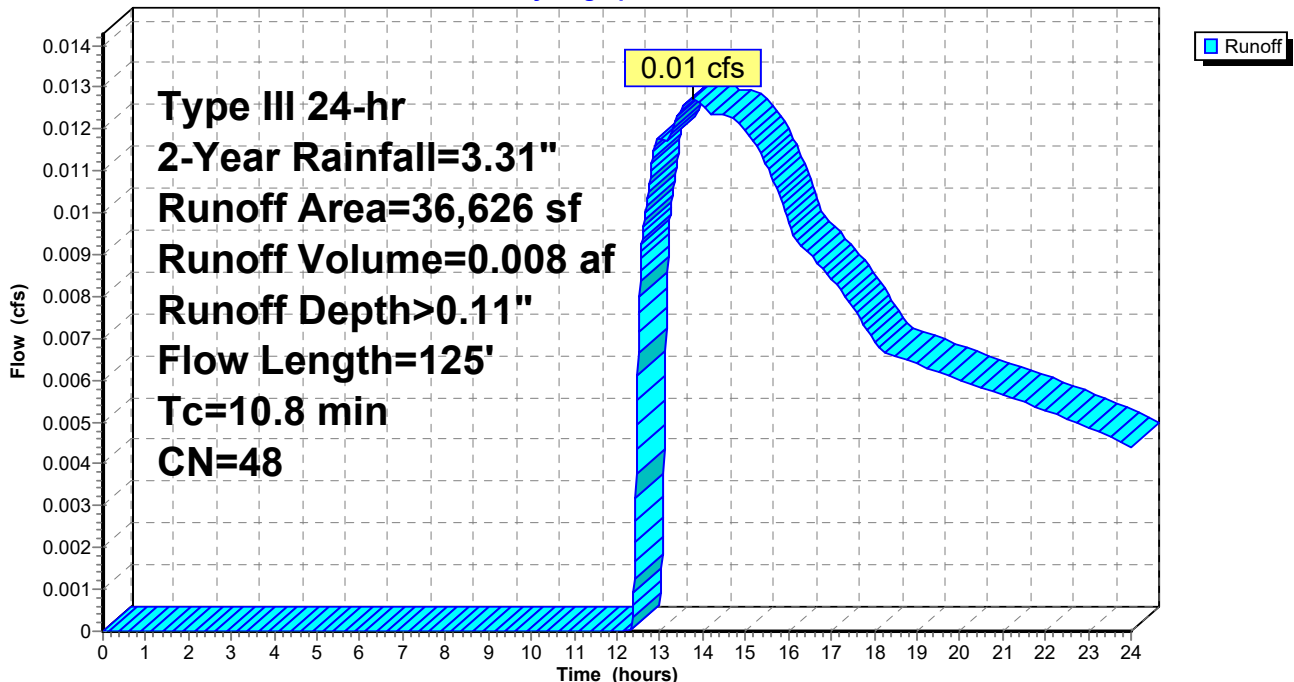

**2023-03-10\_POST-DRAINAGE**

Prepared by {enter your company name here}

HydroCAD® 10.10-3a s/n 11112 © 2020 HydroCAD Software Solutions LLC

Post Construction Runoff  
Type III 24-hr 2-Year Rainfall=3.31"

Printed 6/20/2023

Page 3

**Summary for Subcatchment P1B: To Recharge 1**

Runoff = 1.80 cfs @ 12.16 hrs, Volume= 0.154 af, Depth> 1.55"

Runoff by SCS TR-20 method, UH=SCS, Weighted-CN, Time Span= 0.00-24.00 hrs, dt= 0.01 hrs  
Type III 24-hr 2-Year Rainfall=3.31"

Area (sf)	CN	Description
* 19,628	98	Impervious
1,448	39	>75% Grass cover, Good, HSG A
21,790	74	>75% Grass cover, Good, HSG C
8,739	70	Woods, Good, HSG C
297	80	>75% Grass cover, Good, HSG D
51,902	81	Weighted Average
32,274		62.18% Pervious Area
19,628		37.82% Impervious Area

Tc (min)	Length (feet)	Slope (ft/ft)	Velocity (ft/sec)	Capacity (cfs)	Description
10.0	50	0.1400	0.08		<b>Sheet Flow, Wood Sheet Flow</b> Woods: Dense underbrush n= 0.800 P2= 3.10"
1.5	120	0.0750	1.37		<b>Shallow Concentrated Flow, Woods Concentrated Flow</b> Woodland Kv= 5.0 fps
11.5	170	Total			

**Subcatchment P1B: To Recharge 1**

Hydrograph

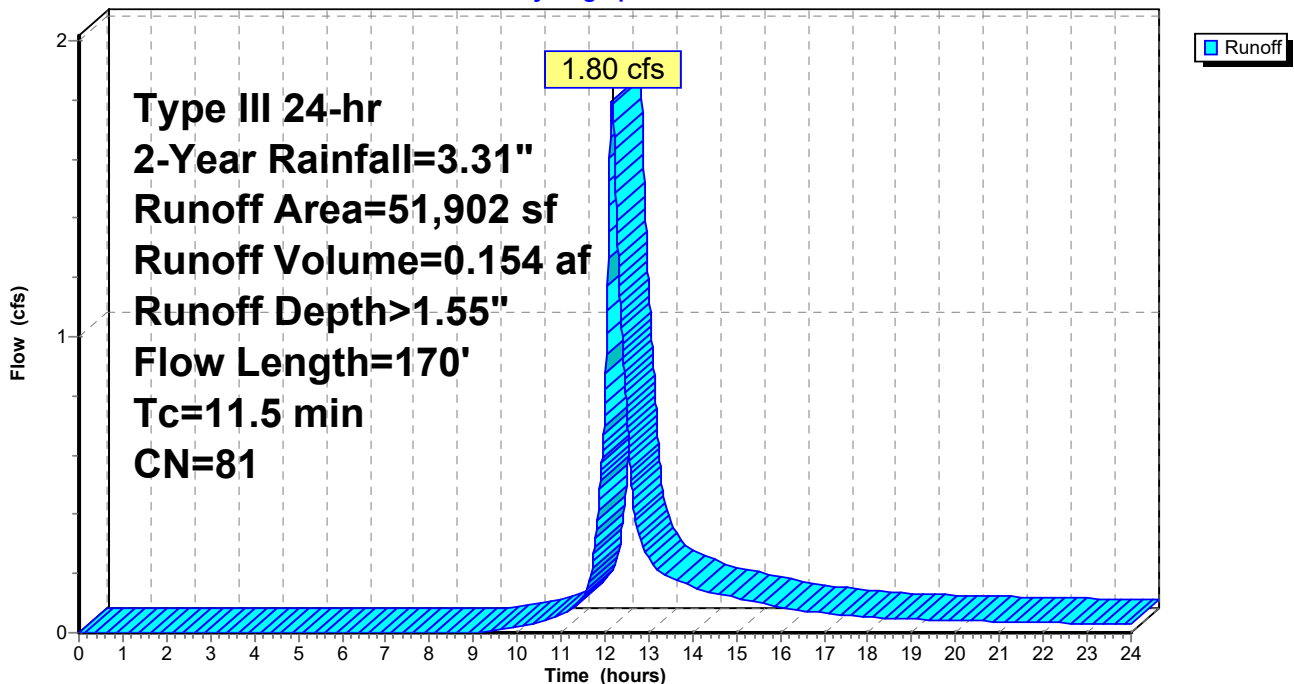

**2023-03-10\_POST-DRAINAGE**

Prepared by {enter your company name here}

HydroCAD® 10.10-3a s/n 11112 © 2020 HydroCAD Software Solutions LLC

Post Construction Runoff  
 Type III 24-hr 2-Year Rainfall=3.31"

Printed 6/20/2023

Page 4

**Summary for Subcatchment P2: Directed West**

Runoff = 0.03 cfs @ 12.08 hrs, Volume= 0.002 af, Depth> 1.29"

Runoff by SCS TR-20 method, UH=SCS, Weighted-CN, Time Span= 0.00-24.00 hrs, dt= 0.01 hrs  
 Type III 24-hr 2-Year Rainfall=3.31"

Area (sf)	CN	Description
473	74	>75% Grass cover, Good, HSG C
407	80	>75% Grass cover, Good, HSG D
880	77	Weighted Average
880		100.00% Pervious Area

Tc (min)	Length (feet)	Slope (ft/ft)	Velocity (ft/sec)	Capacity (cfs)	Description
5.0					Direct Entry,

**Subcatchment P2: Directed West**

Hydrograph

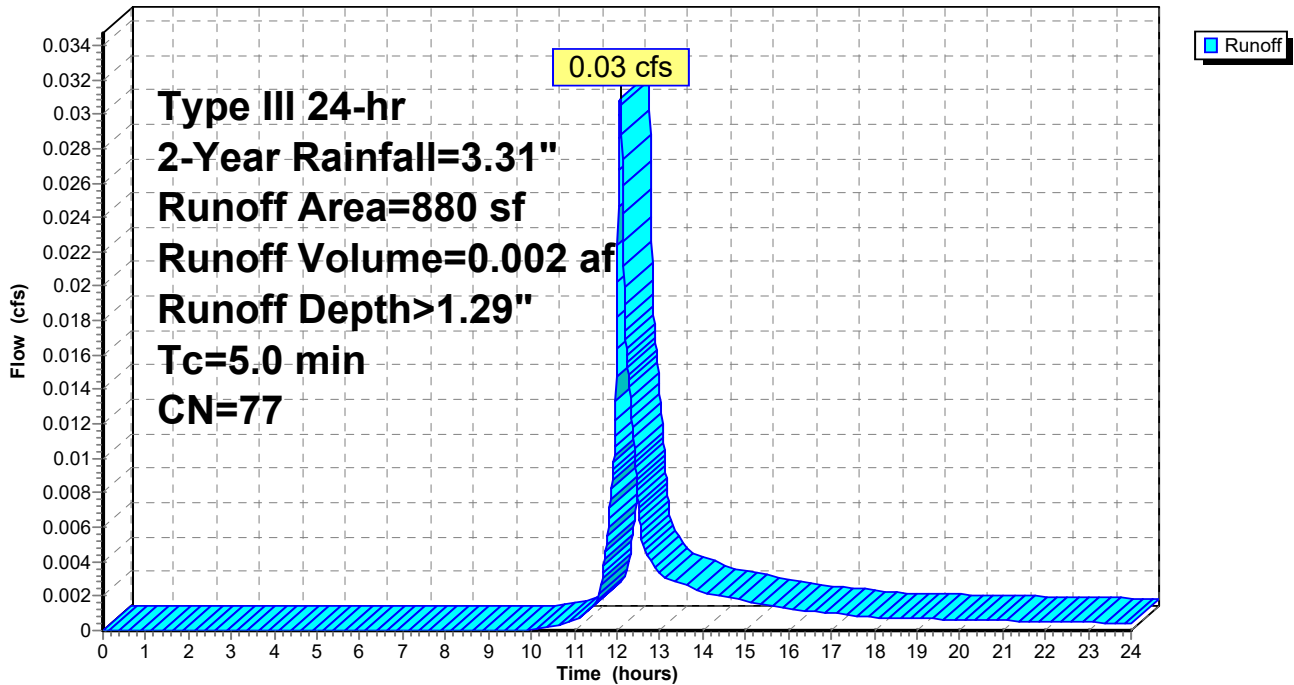

### Summary for Reach P: Total

Inflow Area = 2.053 ac, 25.38% Impervious, Inflow Depth > 0.06" for 2-Year event  
Inflow = 0.03 cfs @ 12.08 hrs, Volume= 0.010 af  
Outflow = 0.03 cfs @ 12.08 hrs, Volume= 0.010 af, Atten= 0%, Lag= 0.0 min

Routing by Stor-Ind+Trans method, Time Span= 0.00-24.00 hrs, dt= 0.01 hrs

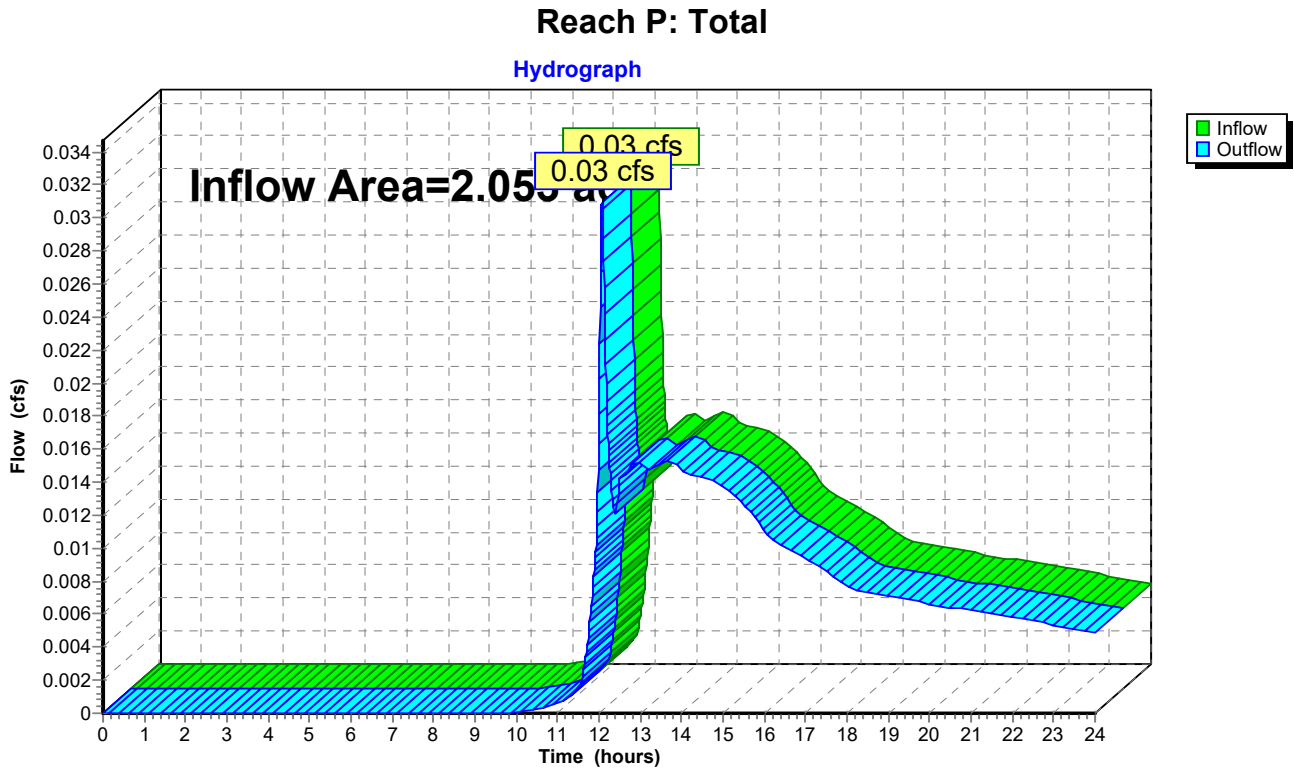

**2023-03-10\_POST-DRAINAGE**

Prepared by {enter your company name here}

HydroCAD® 10.10-3a s/n 11112 © 2020 HydroCAD Software Solutions LLC

Post Construction Runoff  
Type III 24-hr 2-Year Rainfall=3.31"

Printed 6/20/2023

Page 6

**Summary for Reach R1: Reach 1**

Inflow Area = 2.032 ac, 25.63% Impervious, Inflow Depth > 0.04" for 2-Year event  
Inflow = 0.01 cfs @ 13.79 hrs, Volume= 0.008 af  
Outflow = 0.01 cfs @ 13.79 hrs, Volume= 0.008 af, Atten= 0%, Lag= 0.0 min

Routing by Stor-Ind+Trans method, Time Span= 0.00-24.00 hrs, dt= 0.01 hrs

**Reach R1: Reach 1**

Hydrograph

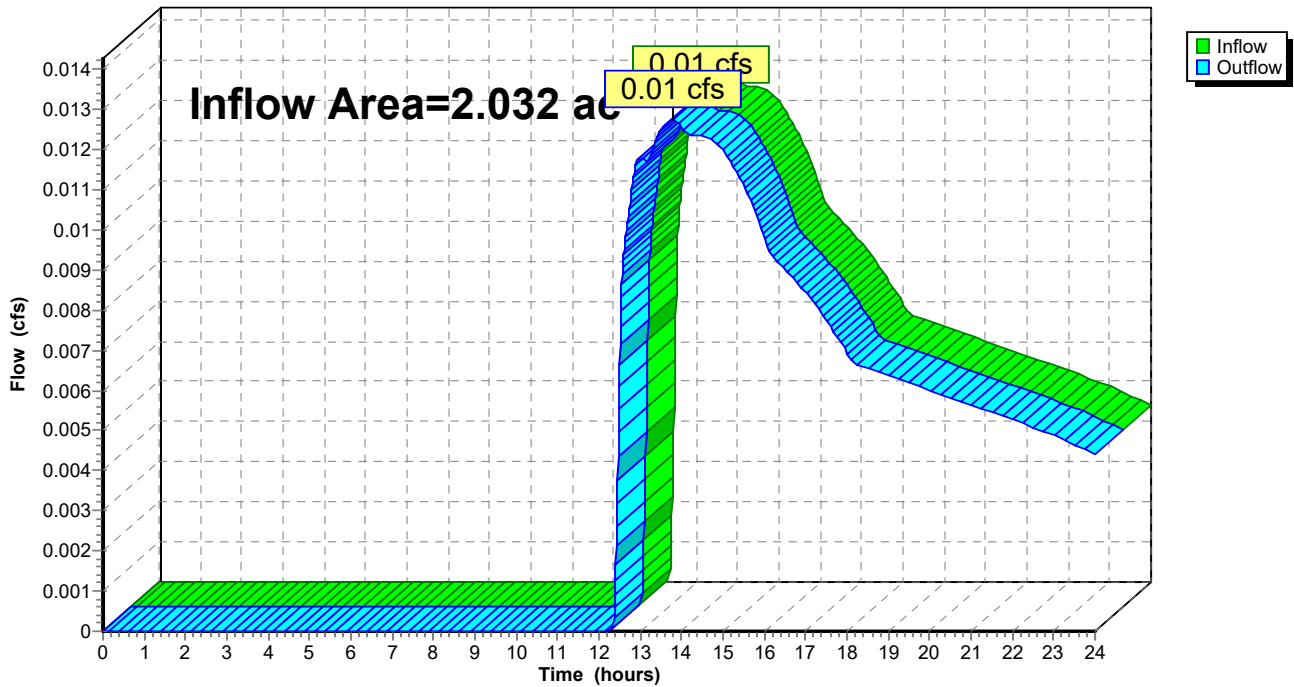

### Summary for Reach R2: Reach 2

Inflow Area = 0.020 ac, 0.00% Impervious, Inflow Depth > 1.29" for 2-Year event  
Inflow = 0.03 cfs @ 12.08 hrs, Volume= 0.002 af  
Outflow = 0.03 cfs @ 12.08 hrs, Volume= 0.002 af, Atten= 0%, Lag= 0.0 min

Routing by Stor-Ind+Trans method, Time Span= 0.00-24.00 hrs, dt= 0.01 hrs

### Reach R2: Reach 2

Hydrograph

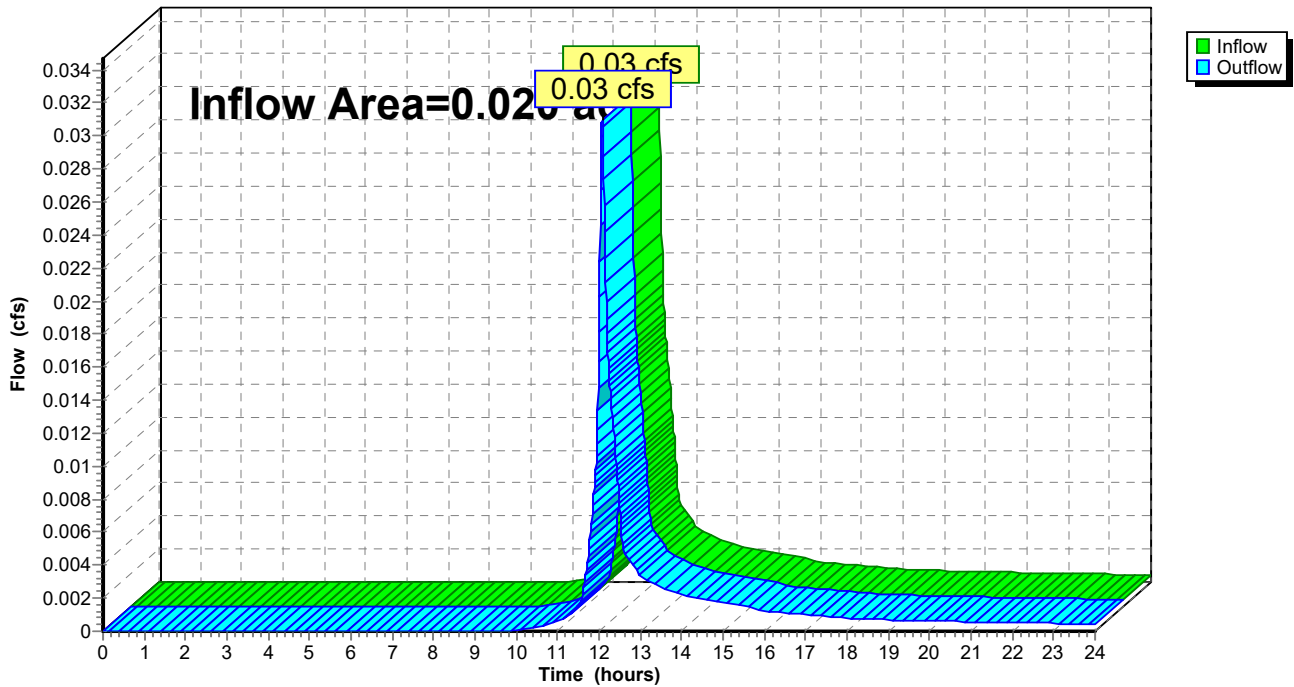

**2023-03-10\_POST-DRAINAGE**

Prepared by {enter your company name here}

HydroCAD® 10.10-3a s/n 11112 © 2020 HydroCAD Software Solutions LLC

Post Construction Runoff  
 Type III 24-hr 2-Year Rainfall=3.31"

Printed 6/20/2023

Page 8

**Summary for Pond PR1: Recharge 1**

Inflow Area = 1.192 ac, 37.82% Impervious, Inflow Depth > 1.55" for 2-Year event  
 Inflow = 1.80 cfs @ 12.16 hrs, Volume= 0.154 af  
 Outflow = 0.35 cfs @ 12.73 hrs, Volume= 0.154 af, Atten= 81%, Lag= 34.3 min  
 Discarded = 0.35 cfs @ 12.73 hrs, Volume= 0.154 af  
 Primary = 0.00 cfs @ 0.00 hrs, Volume= 0.000 af

Routing by Stor-Ind method, Time Span= 0.00-24.00 hrs, dt= 0.01 hrs  
 Peak Elev= 105.33' @ 12.73 hrs Surf.Area= 1,803 sf Storage= 2,383 cf

Plug-Flow detention time= 72.8 min calculated for 0.154 af (100% of inflow)  
 Center-of-Mass det. time= 72.2 min ( 913.6 - 841.4 )

Volume	Invert	Avail.Storage	Storage Description
#1	103.00'	10,735 cf	<b>Custom Stage Data (Prismatic)</b> Listed below (Recalc)
Elevation (feet)	Surf.Area (sq-ft)	Inc.Store (cubic-feet)	Cum.Store (cubic-feet)
103.00	380	0	0
104.00	870	625	625
105.00	1,530	1,200	1,825
106.00	2,345	1,938	3,763
107.00	3,300	2,823	6,585
108.00	5,000	4,150	10,735

Device	Routing	Invert	Outlet Devices
#1	Discarded	103.00'	<b>8.270 in/hr Exfiltration over Surface area</b>
#2	Primary	106.75'	<b>5.0' long (Profile 5) Broad-Crested Rectangular Weir</b> Head (feet) 0.49 0.98 1.48 Coef. (English) 2.79 2.93 3.06

**Discarded OutFlow** Max=0.35 cfs @ 12.73 hrs HW=105.33' (Free Discharge)  
 ↑1=Exfiltration (Exfiltration Controls 0.35 cfs)

**Primary OutFlow** Max=0.00 cfs @ 0.00 hrs HW=103.00' (Free Discharge)  
 ↑2=Broad-Crested Rectangular Weir ( Controls 0.00 cfs)



2023-03-10\_POST-DRAINAGE

Prepared by {enter your company name here}

HydroCAD® 10.10-3a s/n 11112 © 2020 HydroCAD Software Solutions LLC

Post Construction Runoff  
Type III 24-hr 2-Year Rainfall=3.31"

Printed 6/20/2023

Page 9

Pond PR1: Recharge 1

Hydrograph

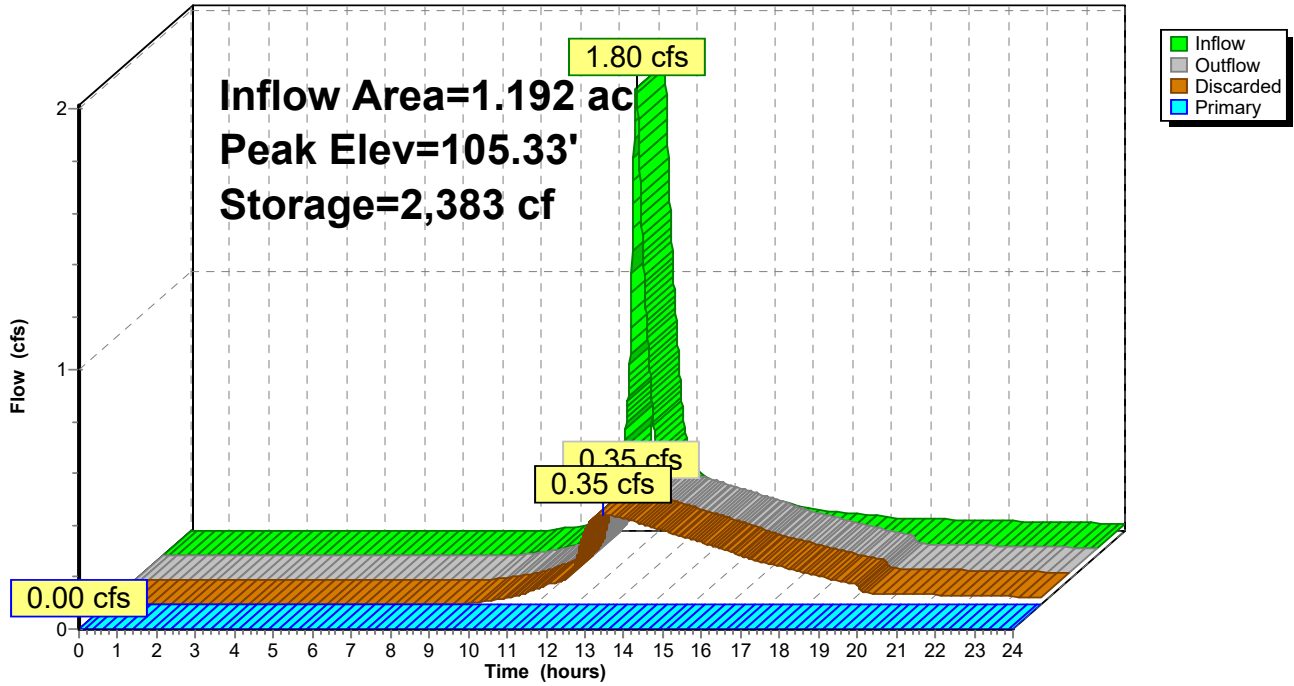

**2023-03-10\_POST-DRAINAGE**

Prepared by {enter your company name here}  
 HydroCAD® 10.10-3a s/n 11112 © 2020 HydroCAD Software Solutions LLC

**Summary for Subcatchment P1A: Directed East**

Runoff = 0.32 cfs @ 12.22 hrs, Volume= 0.047 af, Depth> 0.67"

Runoff by SCS TR-20 method, UH=SCS, Weighted-CN, Time Span= 0.00-24.00 hrs, dt= 0.01 hrs  
 Type III 24-hr 10-Year Rainfall=5.22"

Area (sf)	CN	Description
* 3,060	98	Impervious
14,250	39	>75% Grass cover, Good, HSG A
11,924	30	Woods, Good, HSG A
4,950	74	>75% Grass cover, Good, HSG C
109	70	Woods, Good, HSG C
2,333	80	>75% Grass cover, Good, HSG D
36,626	48	Weighted Average
33,566		91.65% Pervious Area
3,060		8.35% Impervious Area

Tc (min)	Length (feet)	Slope (ft/ft)	Velocity (ft/sec)	Capacity (cfs)	Description
10.0	50	0.1400	0.08		<b>Sheet Flow, Sheet Flow Woods</b> Woods: Dense underbrush n= 0.800 P2= 3.10"
0.8	75	0.1067	1.63		<b>Shallow Concentrated Flow, Concentrated Woods</b> Woodland Kv= 5.0 fps
10.8	125	Total			

**Subcatchment P1A: Directed East**

Hydrograph

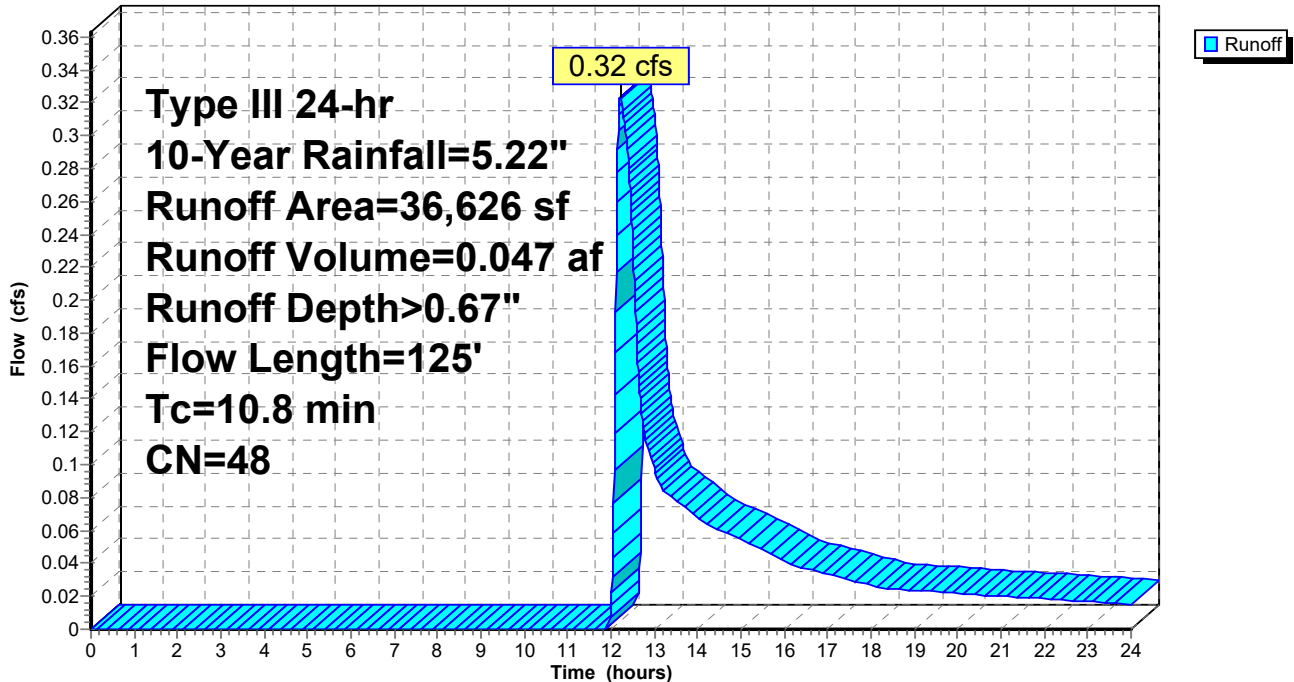

**2023-03-10\_POST-DRAINAGE**

Prepared by {enter your company name here}

HydroCAD® 10.10-3a s/n 11112 © 2020 HydroCAD Software Solutions LLC

Post Construction Runoff  
Type III 24-hr 10-Year Rainfall=5.22"

Printed 6/20/2023

Page 11

**Summary for Subcatchment P1B: To Recharge 1**

Runoff = 3.70 cfs @ 12.16 hrs, Volume= 0.315 af, Depth> 3.17"

Runoff by SCS TR-20 method, UH=SCS, Weighted-CN, Time Span= 0.00-24.00 hrs, dt= 0.01 hrs  
Type III 24-hr 10-Year Rainfall=5.22"

Area (sf)	CN	Description
* 19,628	98	Impervious
1,448	39	>75% Grass cover, Good, HSG A
21,790	74	>75% Grass cover, Good, HSG C
8,739	70	Woods, Good, HSG C
297	80	>75% Grass cover, Good, HSG D
51,902	81	Weighted Average
32,274		62.18% Pervious Area
19,628		37.82% Impervious Area

Tc (min)	Length (feet)	Slope (ft/ft)	Velocity (ft/sec)	Capacity (cfs)	Description
10.0	50	0.1400	0.08		<b>Sheet Flow, Wood Sheet Flow</b> Woods: Dense underbrush n= 0.800 P2= 3.10"
1.5	120	0.0750	1.37		<b>Shallow Concentrated Flow, Woods Concentrated Flow</b> Woodland Kv= 5.0 fps
11.5	170	Total			

**Subcatchment P1B: To Recharge 1**

Hydrograph

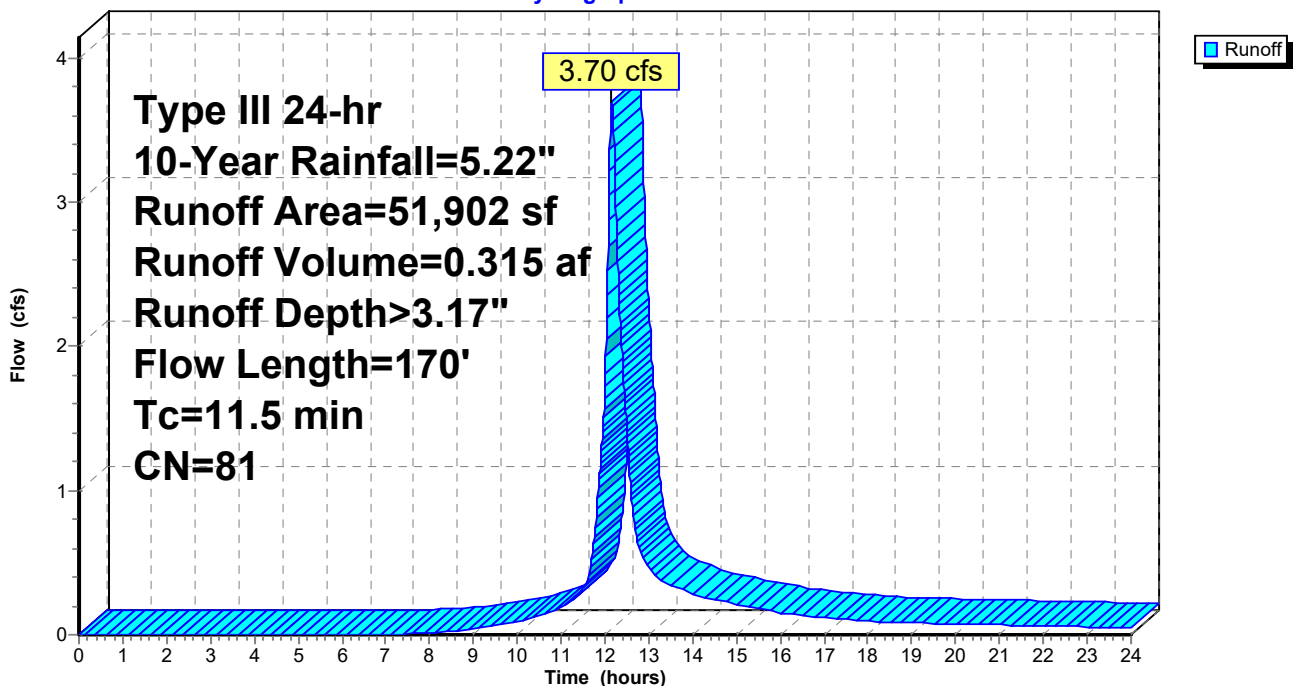

# 2023-03-10\_POST-DRAINAGE

Prepared by {enter your company name here}

HydroCAD® 10.10-3a s/n 11112 © 2020 HydroCAD Software Solutions LLC

Post Construction Runoff

Type III 24-hr 10-Year Rainfall=5.22"

Printed 6/20/2023

Page 12

## Summary for Subcatchment P2: Directed West

Runoff = 0.07 cfs @ 12.08 hrs, Volume= 0.005 af, Depth> 2.81"

Runoff by SCS TR-20 method, UH=SCS, Weighted-CN, Time Span= 0.00-24.00 hrs, dt= 0.01 hrs  
Type III 24-hr 10-Year Rainfall=5.22"

Area (sf)	CN	Description
473	74	>75% Grass cover, Good, HSG C
407	80	>75% Grass cover, Good, HSG D
880	77	Weighted Average
880		100.00% Pervious Area

Tc (min)	Length (feet)	Slope (ft/ft)	Velocity (ft/sec)	Capacity (cfs)	Description
5.0					Direct Entry,

## Subcatchment P2: Directed West

Hydrograph

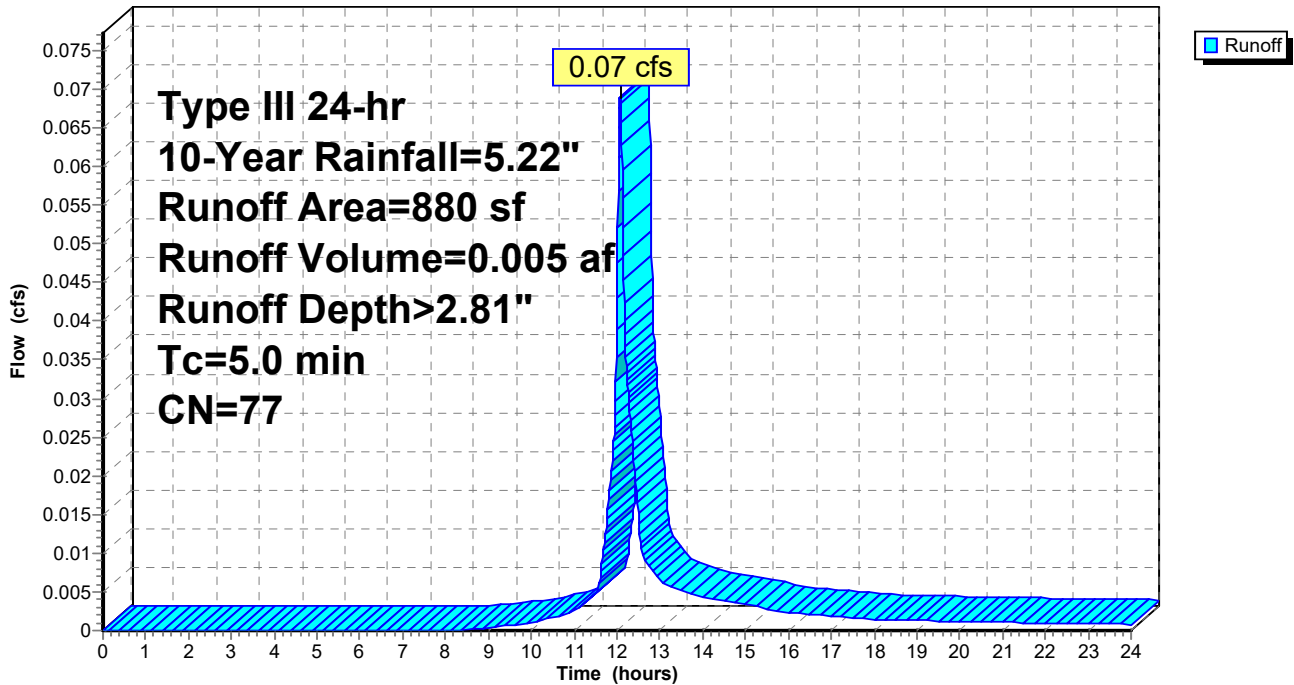

### Summary for Reach P: Total

Inflow Area = 2.053 ac, 25.38% Impervious, Inflow Depth > 0.30" for 10-Year event  
Inflow = 0.36 cfs @ 12.21 hrs, Volume= 0.052 af  
Outflow = 0.36 cfs @ 12.21 hrs, Volume= 0.052 af, Atten= 0%, Lag= 0.0 min

Routing by Stor-Ind+Trans method, Time Span= 0.00-24.00 hrs, dt= 0.01 hrs

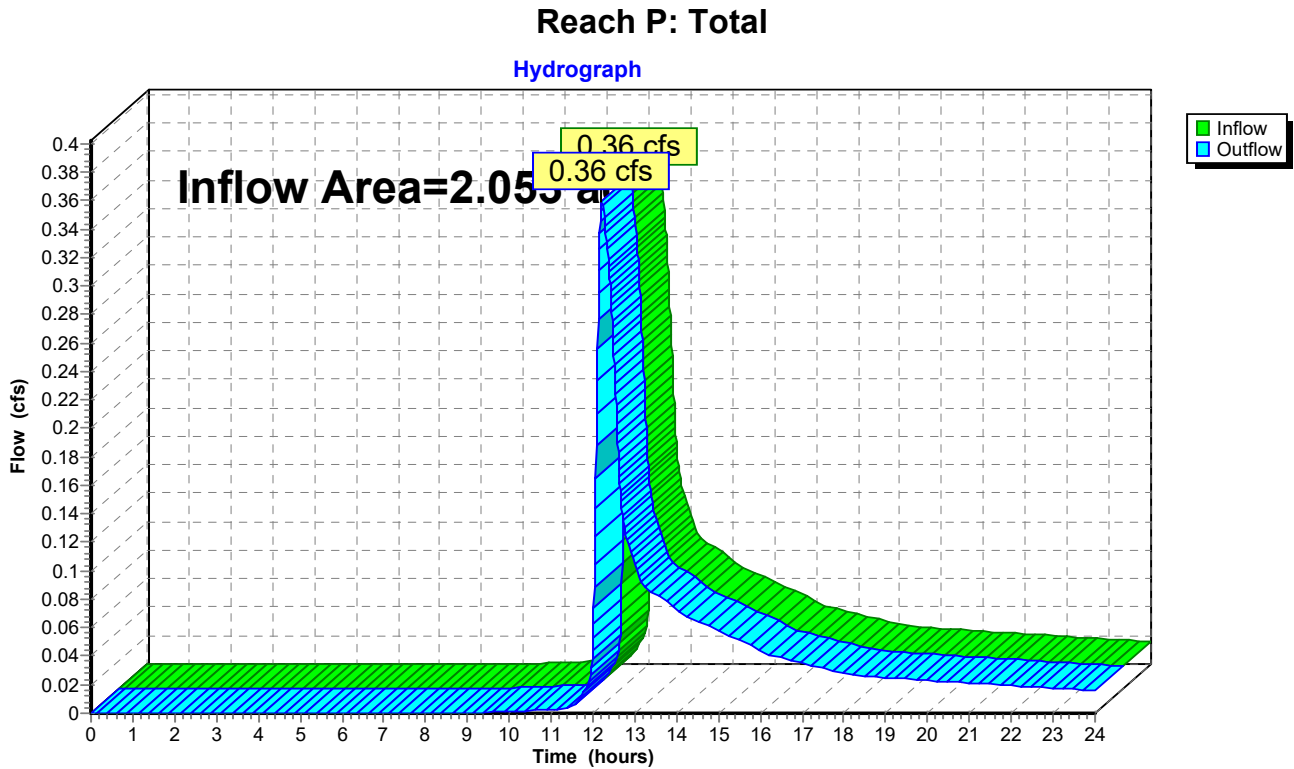

### Summary for Reach R1: Reach 1

Inflow Area = 2.032 ac, 25.63% Impervious, Inflow Depth > 0.28" for 10-Year event  
Inflow = 0.32 cfs @ 12.22 hrs, Volume= 0.047 af  
Outflow = 0.32 cfs @ 12.22 hrs, Volume= 0.047 af, Atten= 0%, Lag= 0.0 min

Routing by Stor-Ind+Trans method, Time Span= 0.00-24.00 hrs, dt= 0.01 hrs

### Reach R1: Reach 1

Hydrograph

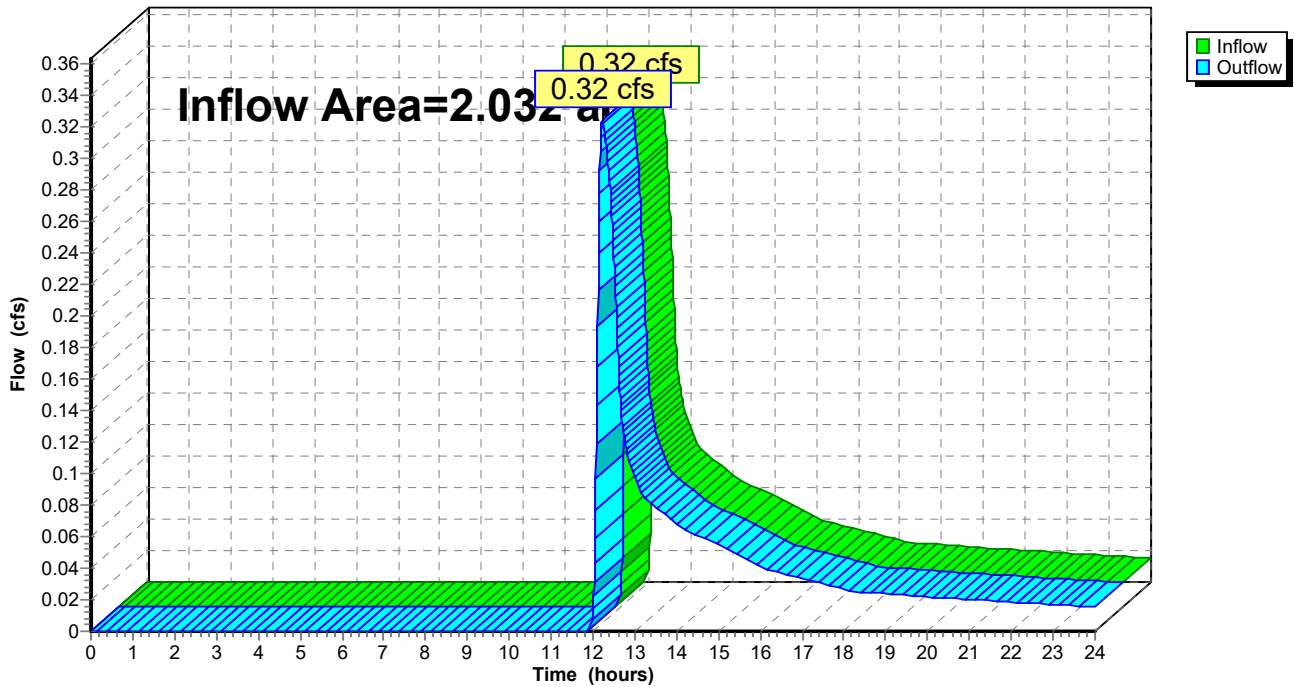

### Summary for Reach R2: Reach 2

Inflow Area = 0.020 ac, 0.00% Impervious, Inflow Depth > 2.81" for 10-Year event  
Inflow = 0.07 cfs @ 12.08 hrs, Volume= 0.005 af  
Outflow = 0.07 cfs @ 12.08 hrs, Volume= 0.005 af, Atten= 0%, Lag= 0.0 min

Routing by Stor-Ind+Trans method, Time Span= 0.00-24.00 hrs, dt= 0.01 hrs

### Reach R2: Reach 2

Hydrograph

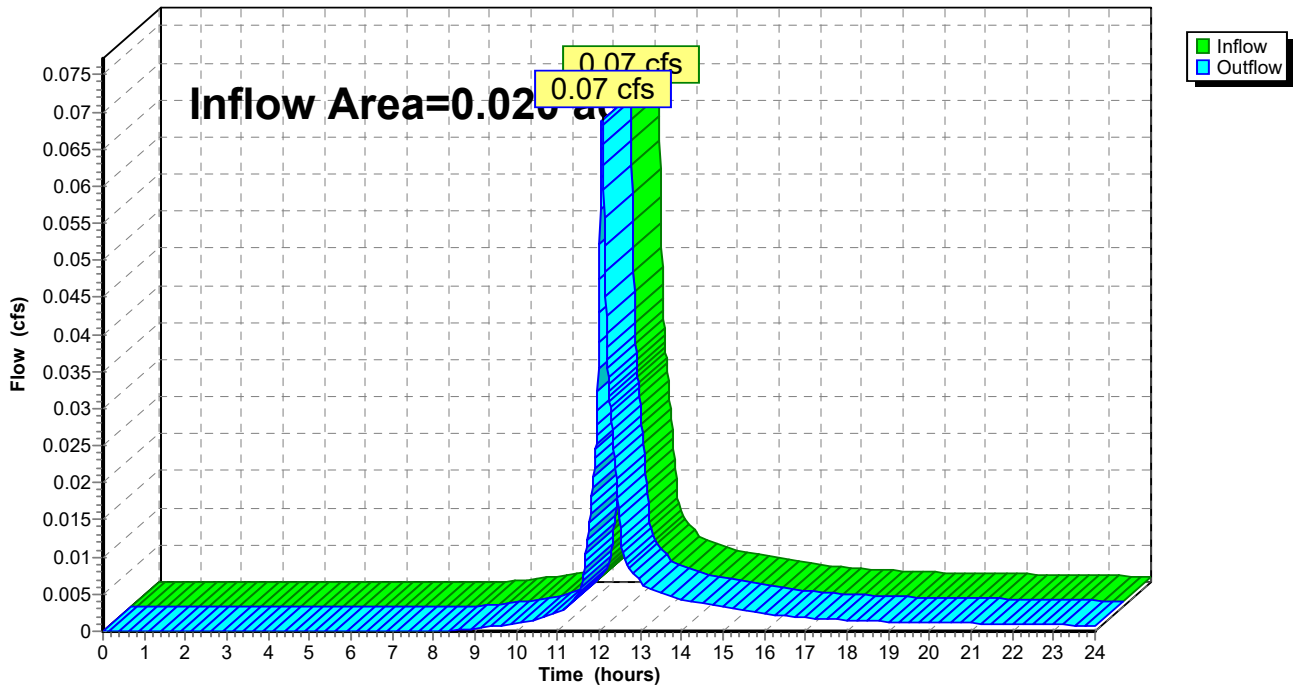

# 2023-03-10\_POST-DRAINAGE

Prepared by {enter your company name here}

HydroCAD® 10.10-3a s/n 11112 © 2020 HydroCAD Software Solutions LLC

Post Construction Runoff

Type III 24-hr 10-Year Rainfall=5.22"

Printed 6/20/2023

Page 16

## Summary for Pond PR1: Recharge 1

Inflow Area = 1.192 ac, 37.82% Impervious, Inflow Depth > 3.17" for 10-Year event  
Inflow = 3.70 cfs @ 12.16 hrs, Volume= 0.315 af  
Outflow = 0.58 cfs @ 12.81 hrs, Volume= 0.315 af, Atten= 84%, Lag= 39.1 min  
Discarded = 0.58 cfs @ 12.81 hrs, Volume= 0.315 af  
Primary = 0.00 cfs @ 0.00 hrs, Volume= 0.000 af

Routing by Stor-Ind method, Time Span= 0.00-24.00 hrs, dt= 0.01 hrs  
Peak Elev= 106.69' @ 12.81 hrs Surf.Area= 3,008 sf Storage= 5,621 cf

Plug-Flow detention time= 112.2 min calculated for 0.315 af (100% of inflow)  
Center-of-Mass det. time= 111.6 min ( 932.6 - 821.0 )

Volume	Invert	Avail.Storage	Storage Description
#1	103.00'	10,735 cf	<b>Custom Stage Data (Prismatic)</b> Listed below (Recalc)
Elevation (feet)	Surf.Area (sq-ft)	Inc.Store (cubic-feet)	Cum.Store (cubic-feet)
103.00	380	0	0
104.00	870	625	625
105.00	1,530	1,200	1,825
106.00	2,345	1,938	3,763
107.00	3,300	2,823	6,585
108.00	5,000	4,150	10,735

Device	Routing	Invert	Outlet Devices
#1	Discarded	103.00'	<b>8.270 in/hr Exfiltration over Surface area</b>
#2	Primary	106.75'	<b>5.0' long (Profile 5) Broad-Crested Rectangular Weir</b> Head (feet) 0.49 0.98 1.48 Coef. (English) 2.79 2.93 3.06

**Discarded OutFlow** Max=0.58 cfs @ 12.81 hrs HW=106.69' (Free Discharge)

↑**1=Exfiltration** (Exfiltration Controls 0.58 cfs)

**Primary OutFlow** Max=0.00 cfs @ 0.00 hrs HW=103.00' (Free Discharge)

↑**2=Broad-Crested Rectangular Weir** ( Controls 0.00 cfs)



### Pond PR1: Recharge 1

Hydrograph

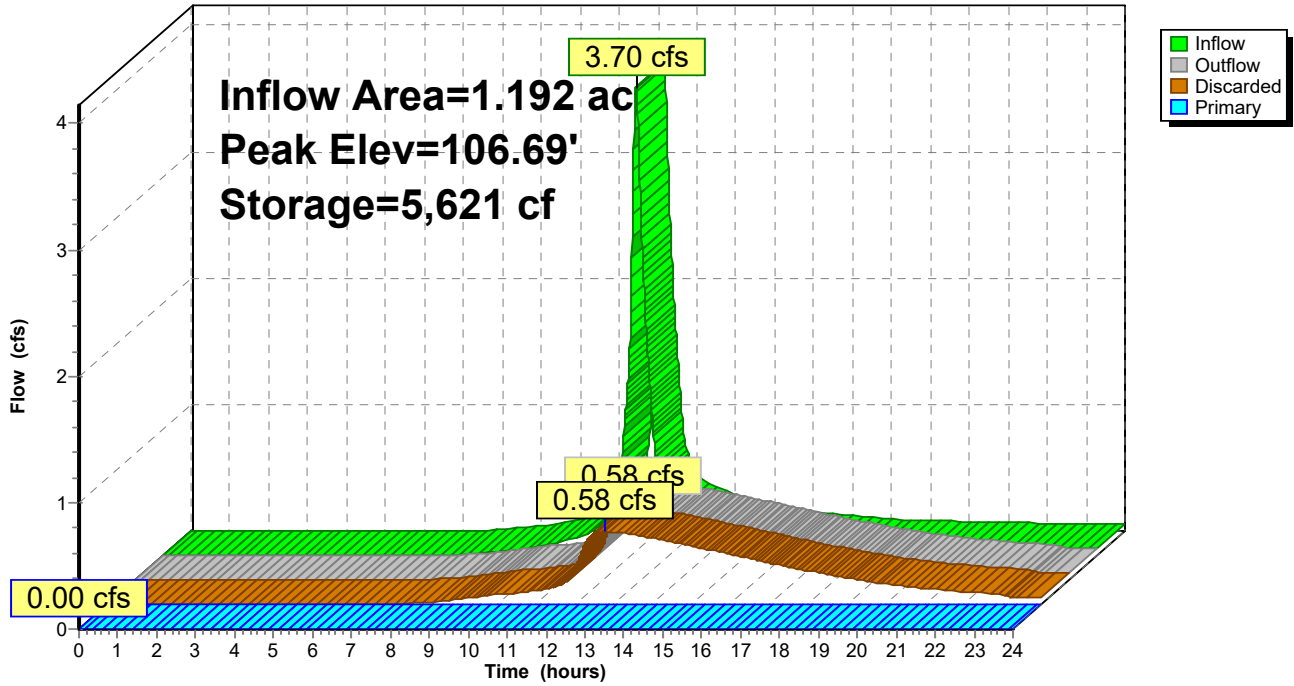

**2023-03-10\_POST-DRAINAGE**

Prepared by {enter your company name here}

HydroCAD® 10.10-3a s/n 11112 © 2020 HydroCAD Software Solutions LLC

Post Construction Runoff  
Type III 24-hr 25-Year Rainfall=6.41"

Printed 6/20/2023

Page 18

**Summary for Subcatchment P1A: Directed East**

Runoff = 0.77 cfs @ 12.18 hrs, Volume= 0.083 af, Depth> 1.19"

Runoff by SCS TR-20 method, UH=SCS, Weighted-CN, Time Span= 0.00-24.00 hrs, dt= 0.01 hrs  
Type III 24-hr 25-Year Rainfall=6.41"

Area (sf)	CN	Description
* 3,060	98	Impervious
14,250	39	>75% Grass cover, Good, HSG A
11,924	30	Woods, Good, HSG A
4,950	74	>75% Grass cover, Good, HSG C
109	70	Woods, Good, HSG C
2,333	80	>75% Grass cover, Good, HSG D
36,626	48	Weighted Average
33,566		91.65% Pervious Area
3,060		8.35% Impervious Area

Tc (min)	Length (feet)	Slope (ft/ft)	Velocity (ft/sec)	Capacity (cfs)	Description
10.0	50	0.1400	0.08		<b>Sheet Flow, Sheet Flow Woods</b> Woods: Dense underbrush n= 0.800 P2= 3.10"
0.8	75	0.1067	1.63		<b>Shallow Concentrated Flow, Concentrated Woods</b> Woodland Kv= 5.0 fps
10.8	125	Total			

**Subcatchment P1A: Directed East**

Hydrograph

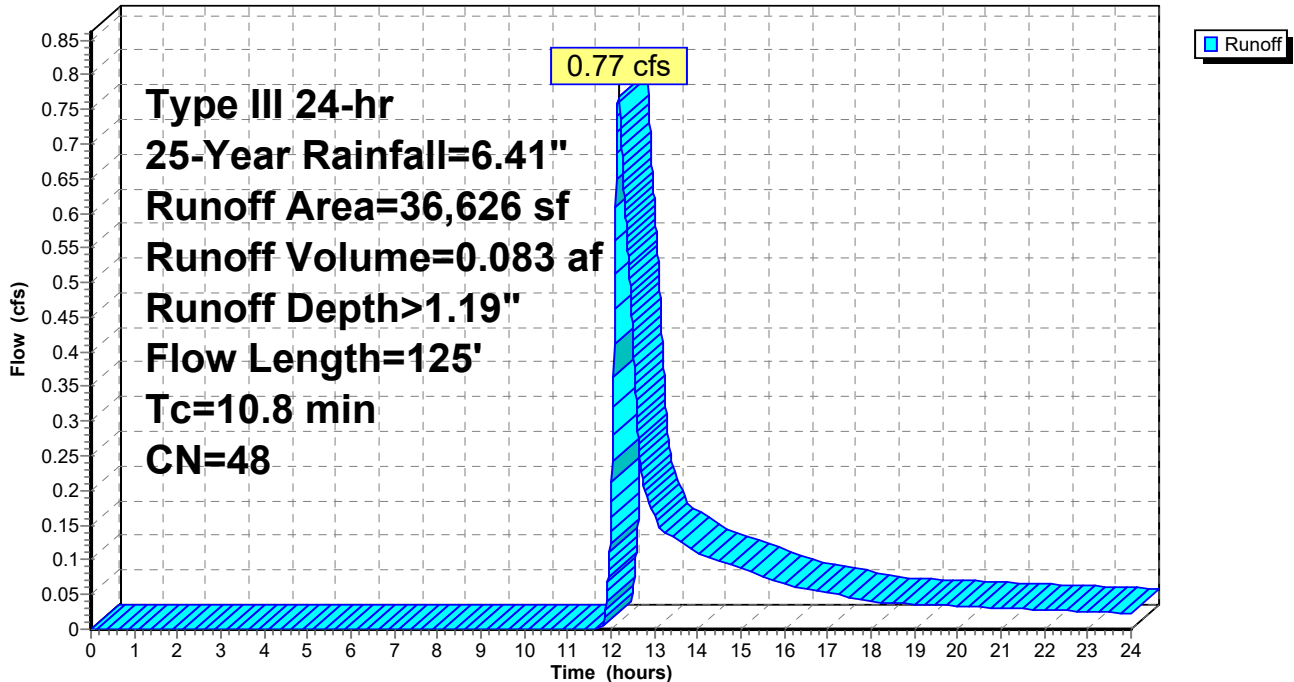

**2023-03-10\_POST-DRAINAGE**

Prepared by {enter your company name here}

HydroCAD® 10.10-3a s/n 11112 © 2020 HydroCAD Software Solutions LLC

Post Construction Runoff  
Type III 24-hr 25-Year Rainfall=6.41"

Printed 6/20/2023

Page 19

**Summary for Subcatchment P1B: To Recharge 1**

Runoff = 4.93 cfs @ 12.16 hrs, Volume= 0.422 af, Depth> 4.25"

Runoff by SCS TR-20 method, UH=SCS, Weighted-CN, Time Span= 0.00-24.00 hrs, dt= 0.01 hrs  
Type III 24-hr 25-Year Rainfall=6.41"

Area (sf)	CN	Description
* 19,628	98	Impervious
1,448	39	>75% Grass cover, Good, HSG A
21,790	74	>75% Grass cover, Good, HSG C
8,739	70	Woods, Good, HSG C
297	80	>75% Grass cover, Good, HSG D
51,902	81	Weighted Average
32,274		62.18% Pervious Area
19,628		37.82% Impervious Area

Tc (min)	Length (feet)	Slope (ft/ft)	Velocity (ft/sec)	Capacity (cfs)	Description
10.0	50	0.1400	0.08		<b>Sheet Flow, Wood Sheet Flow</b> Woods: Dense underbrush n= 0.800 P2= 3.10"
1.5	120	0.0750	1.37		<b>Shallow Concentrated Flow, Woods Concentrated Flow</b> Woodland Kv= 5.0 fps
11.5	170	Total			

**Subcatchment P1B: To Recharge 1**

Hydrograph

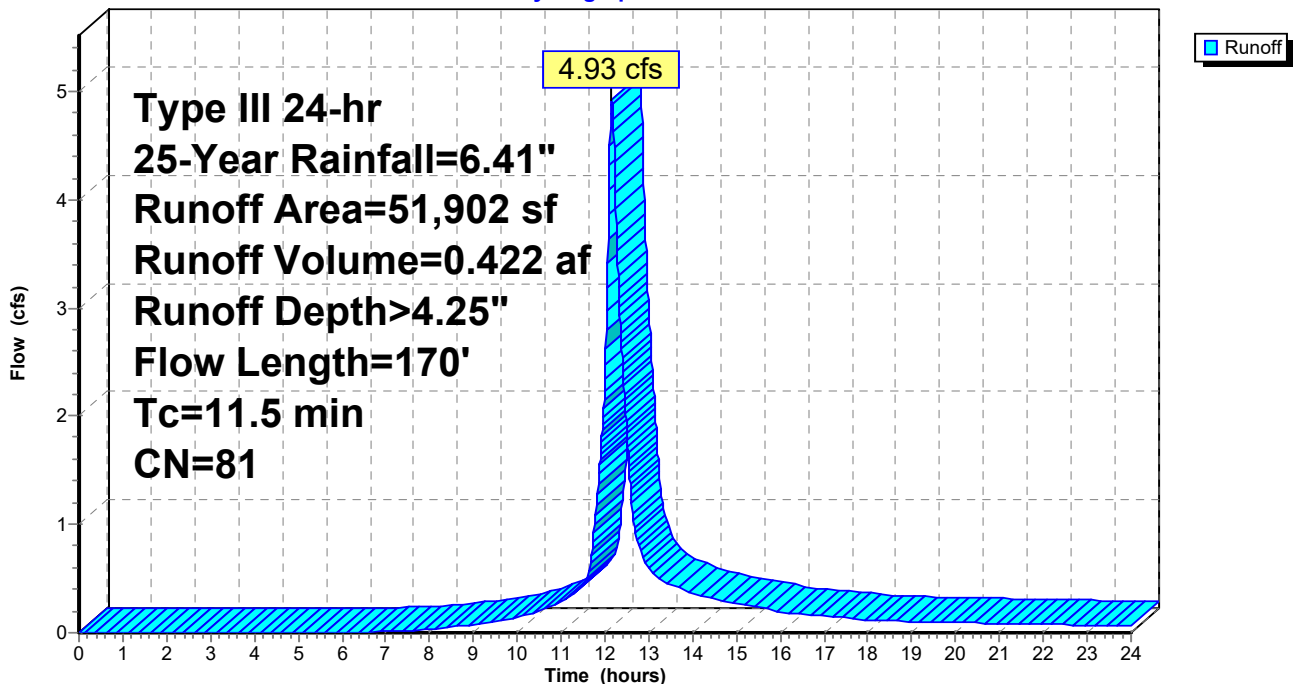

**2023-03-10\_POST-DRAINAGE**

Prepared by {enter your company name here}

HydroCAD® 10.10-3a s/n 11112 © 2020 HydroCAD Software Solutions LLC

Post Construction Runoff  
 Type III 24-hr 25-Year Rainfall=6.41"

Printed 6/20/2023

Page 20

**Summary for Subcatchment P2: Directed West**

Runoff = 0.09 cfs @ 12.07 hrs, Volume= 0.006 af, Depth> 3.84"

Runoff by SCS TR-20 method, UH=SCS, Weighted-CN, Time Span= 0.00-24.00 hrs, dt= 0.01 hrs  
 Type III 24-hr 25-Year Rainfall=6.41"

Area (sf)	CN	Description
473	74	>75% Grass cover, Good, HSG C
407	80	>75% Grass cover, Good, HSG D
880	77	Weighted Average
880		100.00% Pervious Area

Tc (min)	Length (feet)	Slope (ft/ft)	Velocity (ft/sec)	Capacity (cfs)	Description
5.0					Direct Entry,

**Subcatchment P2: Directed West**

Hydrograph

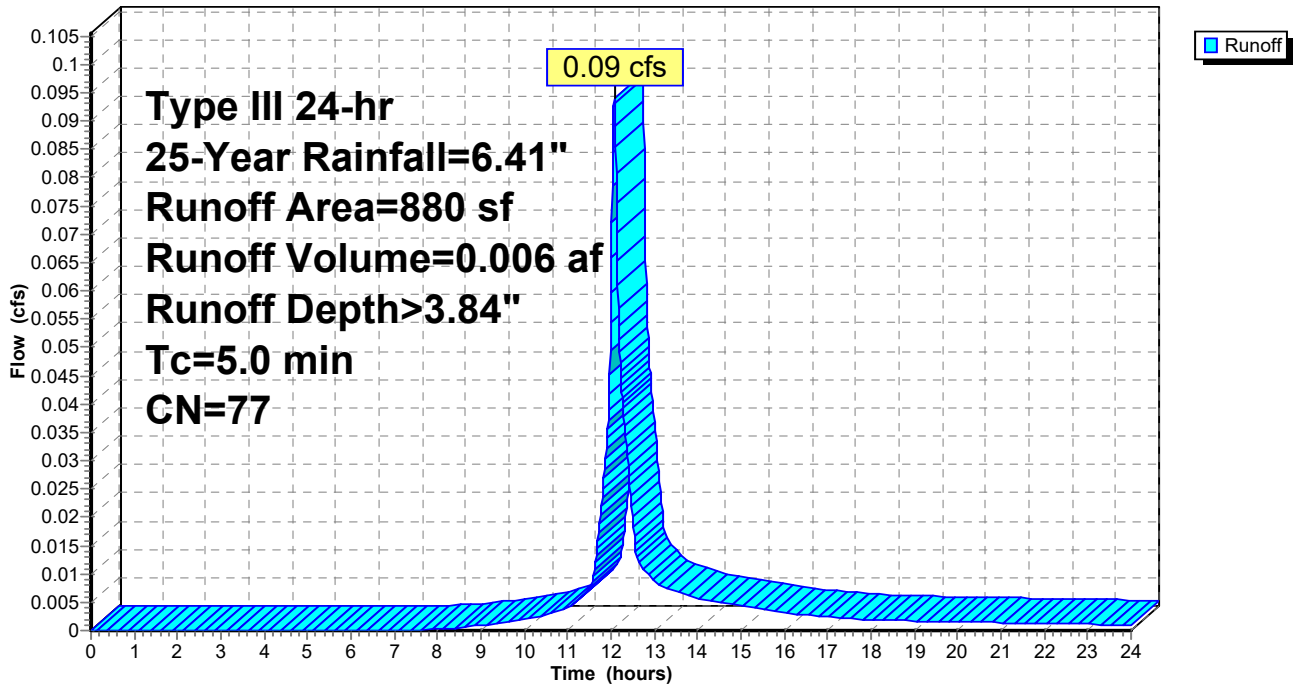

**2023-03-10\_POST-DRAINAGE**

Prepared by {enter your company name here}

HydroCAD® 10.10-3a s/n 11112 © 2020 HydroCAD Software Solutions LLC

Post Construction Runoff

Type III 24-hr 25-Year Rainfall=6.41"

Printed 6/20/2023

Page 21

**Summary for Reach P: Total**

Inflow Area = 2.053 ac, 25.38% Impervious, Inflow Depth > 0.82" for 25-Year event  
Inflow = 2.08 cfs @ 12.43 hrs, Volume= 0.140 af  
Outflow = 2.08 cfs @ 12.43 hrs, Volume= 0.140 af, Atten= 0%, Lag= 0.0 min

Routing by Stor-Ind+Trans method, Time Span= 0.00-24.00 hrs, dt= 0.01 hrs

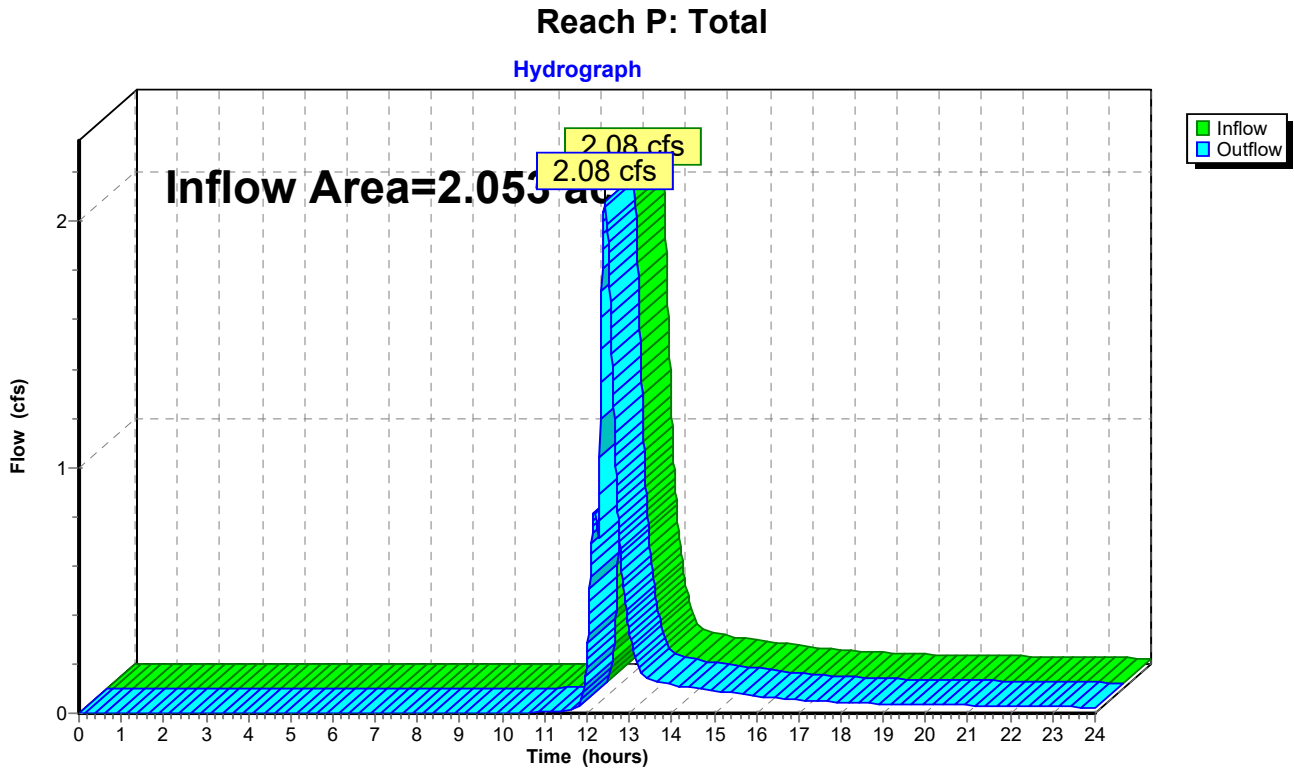

### Summary for Reach R1: Reach 1

Inflow Area = 2.032 ac, 25.63% Impervious, Inflow Depth > 0.79" for 25-Year event  
Inflow = 2.05 cfs @ 12.43 hrs, Volume= 0.134 af  
Outflow = 2.05 cfs @ 12.43 hrs, Volume= 0.134 af, Atten= 0%, Lag= 0.0 min

Routing by Stor-Ind+Trans method, Time Span= 0.00-24.00 hrs, dt= 0.01 hrs

### Reach R1: Reach 1

Hydrograph

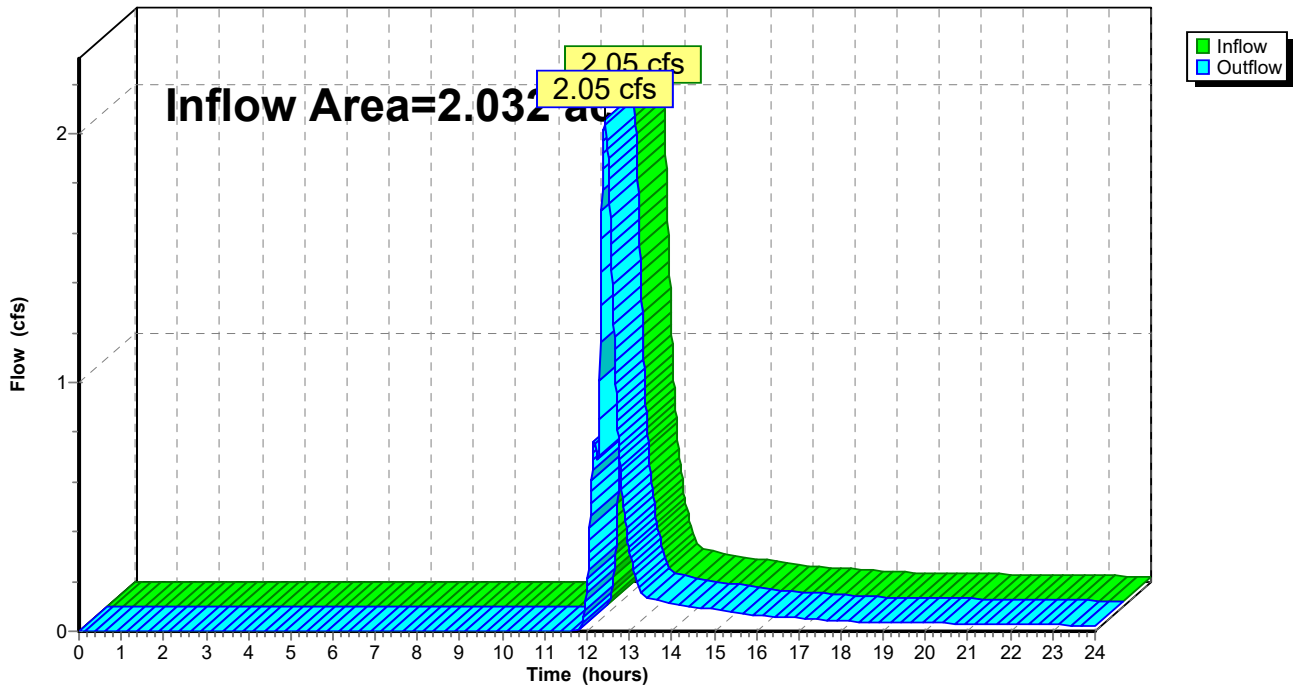

**2023-03-10\_POST-DRAINAGE**

Prepared by {enter your company name here}

HydroCAD® 10.10-3a s/n 11112 © 2020 HydroCAD Software Solutions LLC

Post Construction Runoff  
Type III 24-hr 25-Year Rainfall=6.41"

Printed 6/20/2023

Page 23

**Summary for Reach R2: Reach 2**

Inflow Area = 0.020 ac, 0.00% Impervious, Inflow Depth > 3.84" for 25-Year event  
Inflow = 0.09 cfs @ 12.07 hrs, Volume= 0.006 af  
Outflow = 0.09 cfs @ 12.07 hrs, Volume= 0.006 af, Atten= 0%, Lag= 0.0 min

Routing by Stor-Ind+Trans method, Time Span= 0.00-24.00 hrs, dt= 0.01 hrs

**Reach R2: Reach 2**

Hydrograph

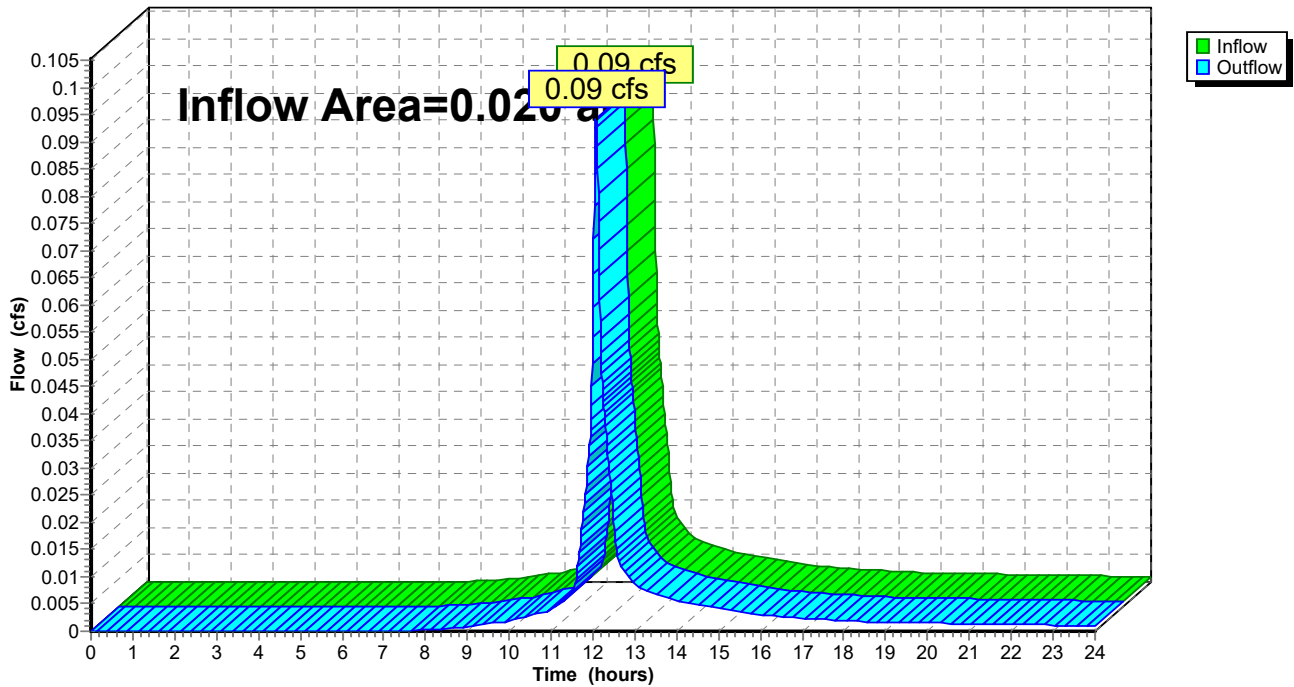

**2023-03-10\_POST-DRAINAGE**

Prepared by {enter your company name here}

HydroCAD® 10.10-3a s/n 11112 © 2020 HydroCAD Software Solutions LLC

Post Construction Runoff  
Type III 24-hr 25-Year Rainfall=6.41"

Printed 6/20/2023

Page 24

**Summary for Pond PR1: Recharge 1**

Inflow Area = 1.192 ac, 37.82% Impervious, Inflow Depth > 4.25" for 25-Year event  
 Inflow = 4.93 cfs @ 12.16 hrs, Volume= 0.422 af  
 Outflow = 2.18 cfs @ 12.44 hrs, Volume= 0.420 af, Atten= 56%, Lag= 17.4 min  
 Discarded = 0.63 cfs @ 12.44 hrs, Volume= 0.370 af  
 Primary = 1.56 cfs @ 12.44 hrs, Volume= 0.050 af

Routing by Stor-Ind method, Time Span= 0.00-24.00 hrs, dt= 0.01 hrs  
 Peak Elev= 106.98' @ 12.44 hrs Surf.Area= 3,282 sf Storage= 6,522 cf

Plug-Flow detention time= 104.7 min calculated for 0.420 af (100% of inflow)  
 Center-of-Mass det. time= 102.4 min ( 915.1 - 812.7 )

Volume	Invert	Avail.Storage	Storage Description
#1	103.00'	10,735 cf	<b>Custom Stage Data (Prismatic)</b> Listed below (Recalc)
Elevation (feet)	Surf.Area (sq-ft)	Inc.Store (cubic-feet)	Cum.Store (cubic-feet)
103.00	380	0	0
104.00	870	625	625
105.00	1,530	1,200	1,825
106.00	2,345	1,938	3,763
107.00	3,300	2,823	6,585
108.00	5,000	4,150	10,735

Device	Routing	Invert	Outlet Devices
#1	Discarded	103.00'	<b>8.270 in/hr Exfiltration over Surface area</b>
#2	Primary	106.75'	<b>5.0' long (Profile 5) Broad-Crested Rectangular Weir</b> Head (feet) 0.49 0.98 1.48 Coef. (English) 2.79 2.93 3.06

**Discarded OutFlow** Max=0.63 cfs @ 12.44 hrs HW=106.98' (Free Discharge)  
 ↗**1=Exfiltration** (Exfiltration Controls 0.63 cfs)

**Primary OutFlow** Max=1.55 cfs @ 12.44 hrs HW=106.98' (Free Discharge)  
 ↗**2=Broad-Crested Rectangular Weir** (Weir Controls 1.55 cfs @ 1.34 fps)



**2023-03-10\_POST-DRAINAGE**

Prepared by {enter your company name here}

HydroCAD® 10.10-3a s/n 11112 © 2020 HydroCAD Software Solutions LLC

Post Construction Runoff  
Type III 24-hr 25-Year Rainfall=6.41"

Printed 6/20/2023

Page 25

**Pond PR1: Recharge 1**

Hydrograph

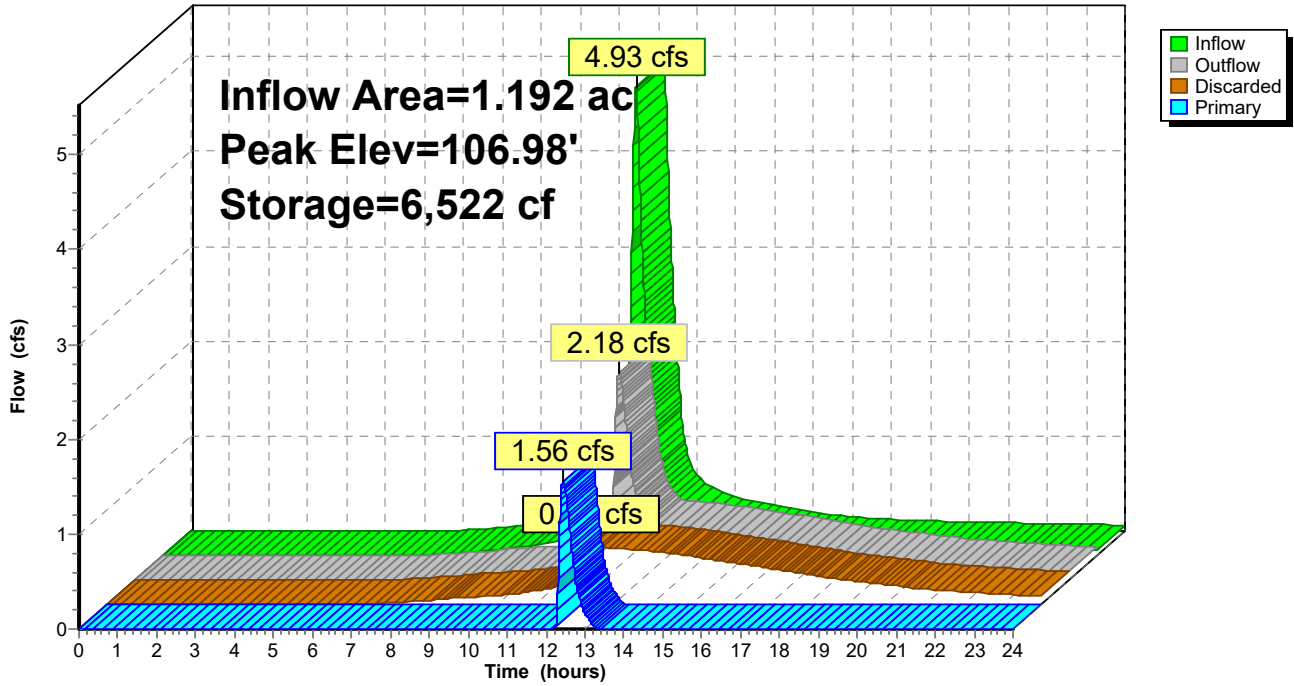

**2023-03-10\_POST-DRAINAGE**

Prepared by {enter your company name here}  
 HydroCAD® 10.10-3a s/n 11112 © 2020 HydroCAD Software Solutions LLC

Post Construction Runoff  
 Type III 24-hr 100-Year Rainfall=8.24"  
 Printed 6/20/2023  
 Page 26

**Summary for Subcatchment P1A: Directed East**

Runoff = 1.64 cfs @ 12.16 hrs, Volume= 0.152 af, Depth> 2.17"

Runoff by SCS TR-20 method, UH=SCS, Weighted-CN, Time Span= 0.00-24.00 hrs, dt= 0.01 hrs  
 Type III 24-hr 100-Year Rainfall=8.24"

Area (sf)	CN	Description
* 3,060	98	Impervious
14,250	39	>75% Grass cover, Good, HSG A
11,924	30	Woods, Good, HSG A
4,950	74	>75% Grass cover, Good, HSG C
109	70	Woods, Good, HSG C
2,333	80	>75% Grass cover, Good, HSG D
36,626	48	Weighted Average
33,566		91.65% Pervious Area
3,060		8.35% Impervious Area

Tc (min)	Length (feet)	Slope (ft/ft)	Velocity (ft/sec)	Capacity (cfs)	Description
10.0	50	0.1400	0.08		<b>Sheet Flow, Sheet Flow Woods</b> Woods: Dense underbrush n= 0.800 P2= 3.10"
0.8	75	0.1067	1.63		<b>Shallow Concentrated Flow, Concentrated Woods</b> Woodland Kv= 5.0 fps
10.8	125	Total			

**Subcatchment P1A: Directed East**

Hydrograph

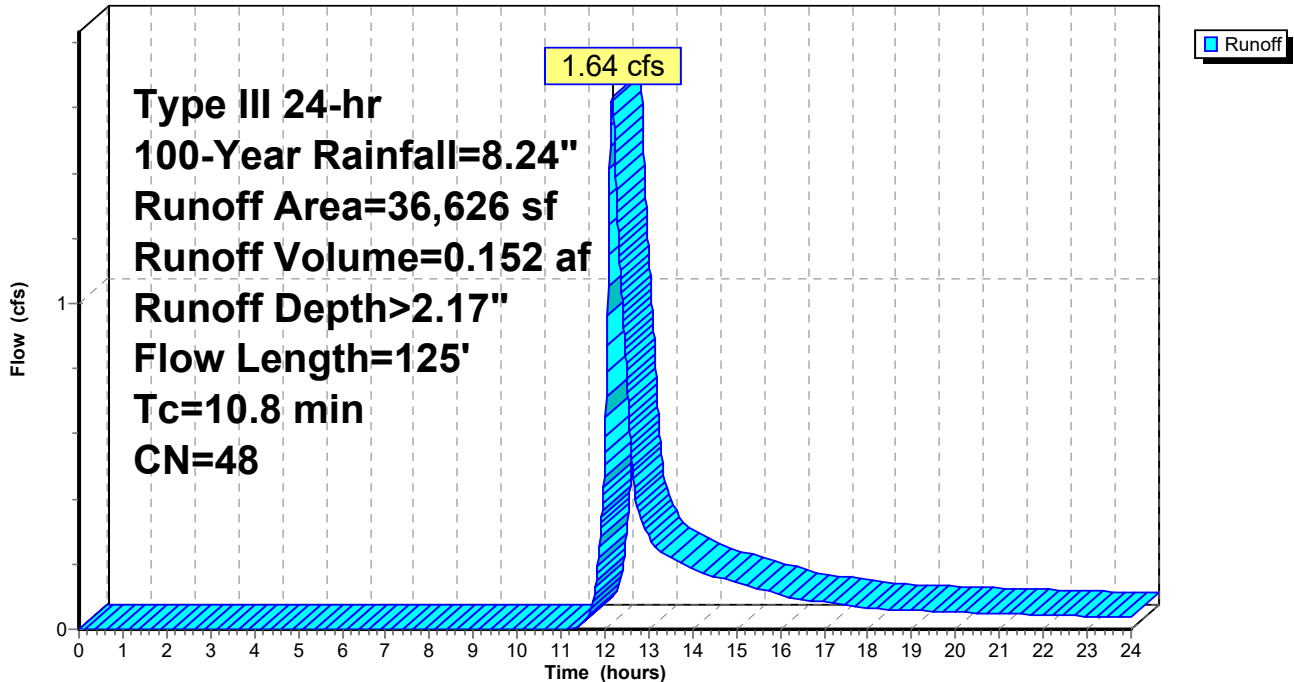

**2023-03-10\_POST-DRAINAGE**

Prepared by {enter your company name here}  
 HydroCAD® 10.10-3a s/n 11112 © 2020 HydroCAD Software Solutions LLC

Post Construction Runoff  
 Type III 24-hr 100-Year Rainfall=8.24"  
 Printed 6/20/2023  
 Page 27

**Summary for Subcatchment P1B: To Recharge 1**

Runoff = 6.84 cfs @ 12.15 hrs, Volume= 0.592 af, Depth> 5.96"

Runoff by SCS TR-20 method, UH=SCS, Weighted-CN, Time Span= 0.00-24.00 hrs, dt= 0.01 hrs  
 Type III 24-hr 100-Year Rainfall=8.24"

Area (sf)	CN	Description
* 19,628	98	Impervious
1,448	39	>75% Grass cover, Good, HSG A
21,790	74	>75% Grass cover, Good, HSG C
8,739	70	Woods, Good, HSG C
297	80	>75% Grass cover, Good, HSG D
51,902	81	Weighted Average
32,274		62.18% Pervious Area
19,628		37.82% Impervious Area

Tc (min)	Length (feet)	Slope (ft/ft)	Velocity (ft/sec)	Capacity (cfs)	Description
10.0	50	0.1400	0.08		<b>Sheet Flow, Wood Sheet Flow</b> Woods: Dense underbrush n= 0.800 P2= 3.10"
1.5	120	0.0750	1.37		<b>Shallow Concentrated Flow, Woods Concentrated Flow</b> Woodland Kv= 5.0 fps
11.5	170	Total			

**Subcatchment P1B: To Recharge 1**

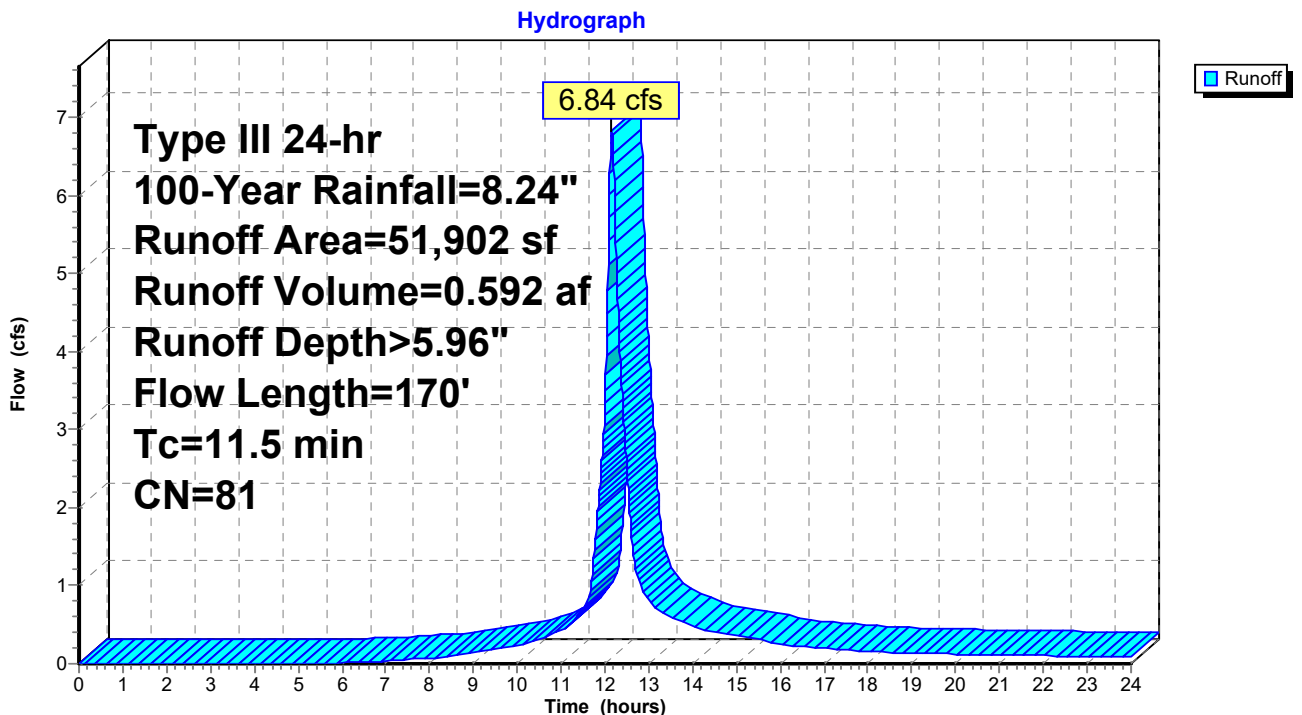

**2023-03-10\_POST-DRAINAGE**

Prepared by {enter your company name here}

HydroCAD® 10.10-3a s/n 11112 © 2020 HydroCAD Software Solutions LLC

Post Construction Runoff  
 Type III 24-hr 100-Year Rainfall=8.24"

Printed 6/20/2023

Page 28

**Summary for Subcatchment P2: Directed West**

Runoff = 0.13 cfs @ 12.07 hrs, Volume= 0.009 af, Depth> 5.49"

Runoff by SCS TR-20 method, UH=SCS, Weighted-CN, Time Span= 0.00-24.00 hrs, dt= 0.01 hrs  
 Type III 24-hr 100-Year Rainfall=8.24"

Area (sf)	CN	Description
473	74	>75% Grass cover, Good, HSG C
407	80	>75% Grass cover, Good, HSG D
880	77	Weighted Average
880		100.00% Pervious Area

Tc (min)	Length (feet)	Slope (ft/ft)	Velocity (ft/sec)	Capacity (cfs)	Description
5.0					Direct Entry,

**Subcatchment P2: Directed West**

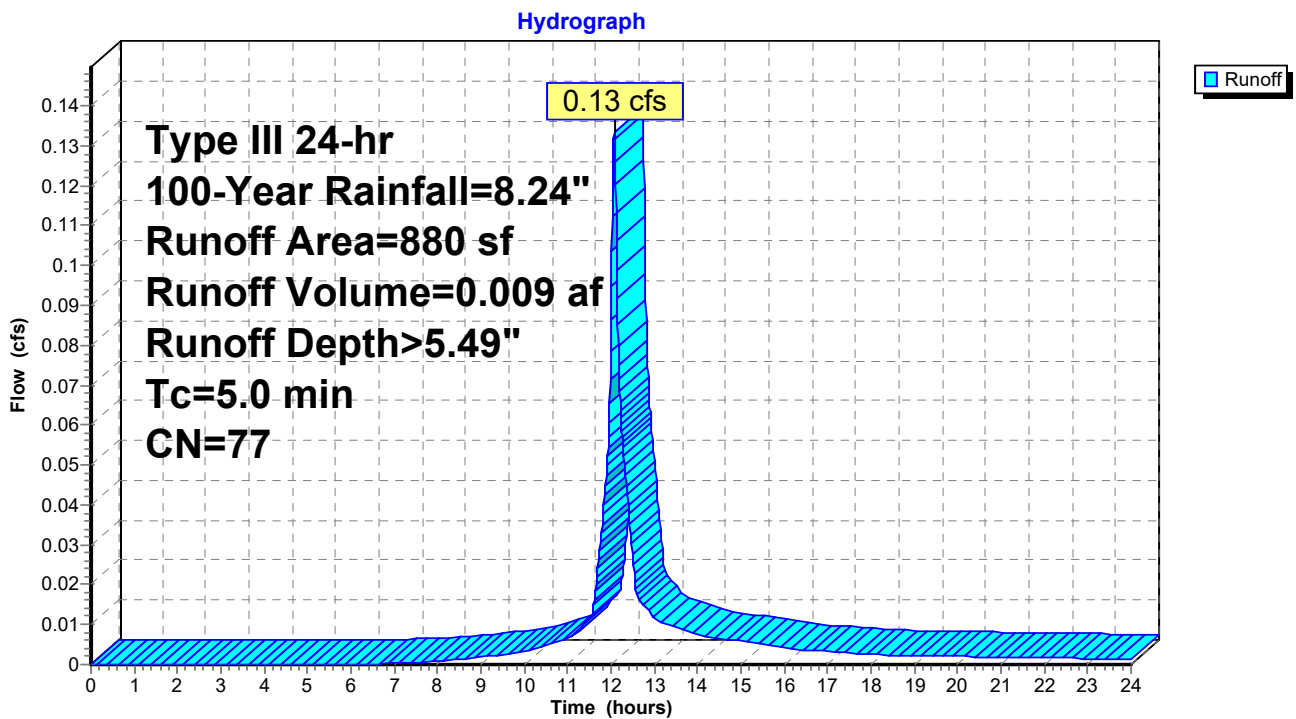

# 2023-03-10\_POST-DRAINAGE

Prepared by {enter your company name here}

HydroCAD® 10.10-3a s/n 11112 © 2020 HydroCAD Software Solutions LLC

Post Construction Runoff  
Type III 24-hr 100-Year Rainfall=8.24"

Printed 6/20/2023

Page 29

## Summary for Reach P: Total

Inflow Area = 2.053 ac, 25.38% Impervious, Inflow Depth > 1.82" for 100-Year event  
Inflow = 5.54 cfs @ 12.26 hrs, Volume= 0.311 af  
Outflow = 5.54 cfs @ 12.26 hrs, Volume= 0.311 af, Atten= 0%, Lag= 0.0 min

Routing by Stor-Ind+Trans method, Time Span= 0.00-24.00 hrs, dt= 0.01 hrs

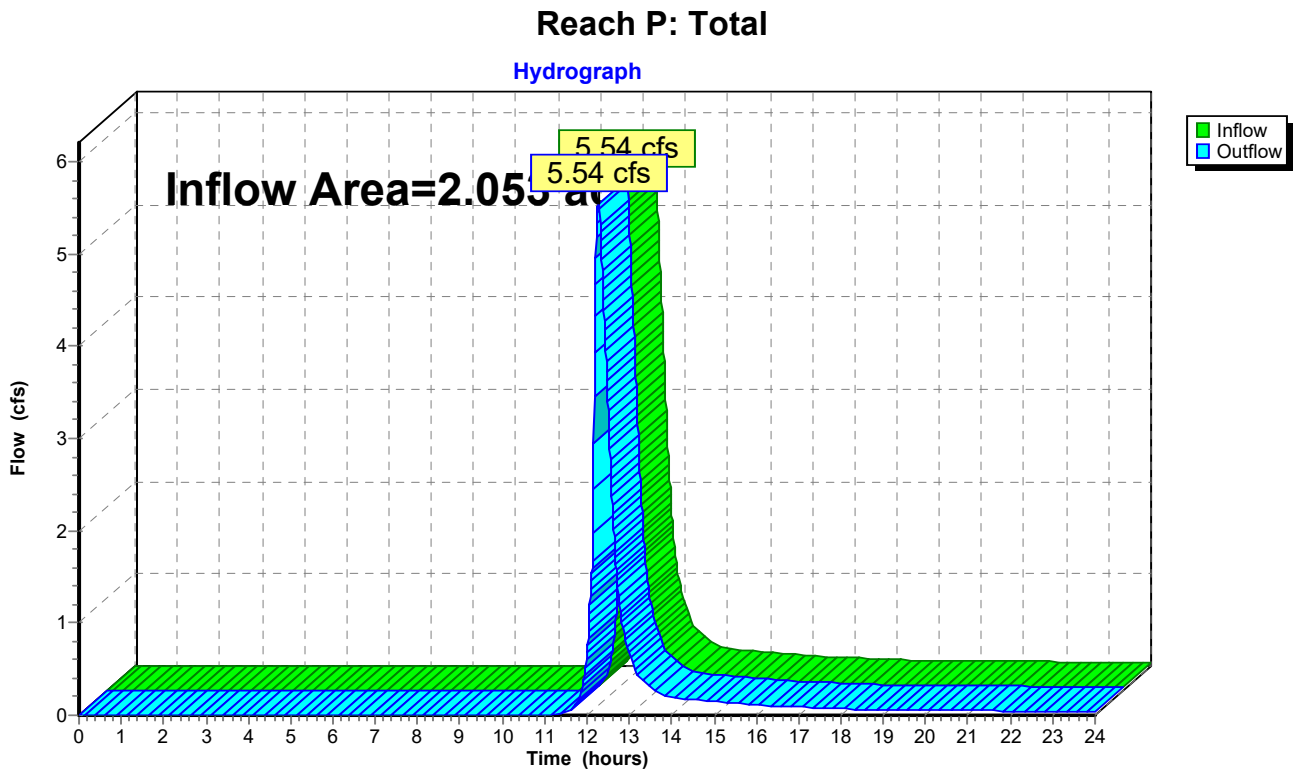

**2023-03-10\_POST-DRAINAGE**

Prepared by {enter your company name here}

HydroCAD® 10.10-3a s/n 11112 © 2020 HydroCAD Software Solutions LLC

Post Construction Runoff  
Type III 24-hr 100-Year Rainfall=8.24"

Printed 6/20/2023

Page 30

**Summary for Reach R1: Reach 1**

Inflow Area = 2.032 ac, 25.63% Impervious, Inflow Depth > 1.78" for 100-Year event  
Inflow = 5.49 cfs @ 12.26 hrs, Volume= 0.302 af  
Outflow = 5.49 cfs @ 12.26 hrs, Volume= 0.302 af, Atten= 0%, Lag= 0.0 min

Routing by Stor-Ind+Trans method, Time Span= 0.00-24.00 hrs, dt= 0.01 hrs

**Reach R1: Reach 1**

Hydrograph

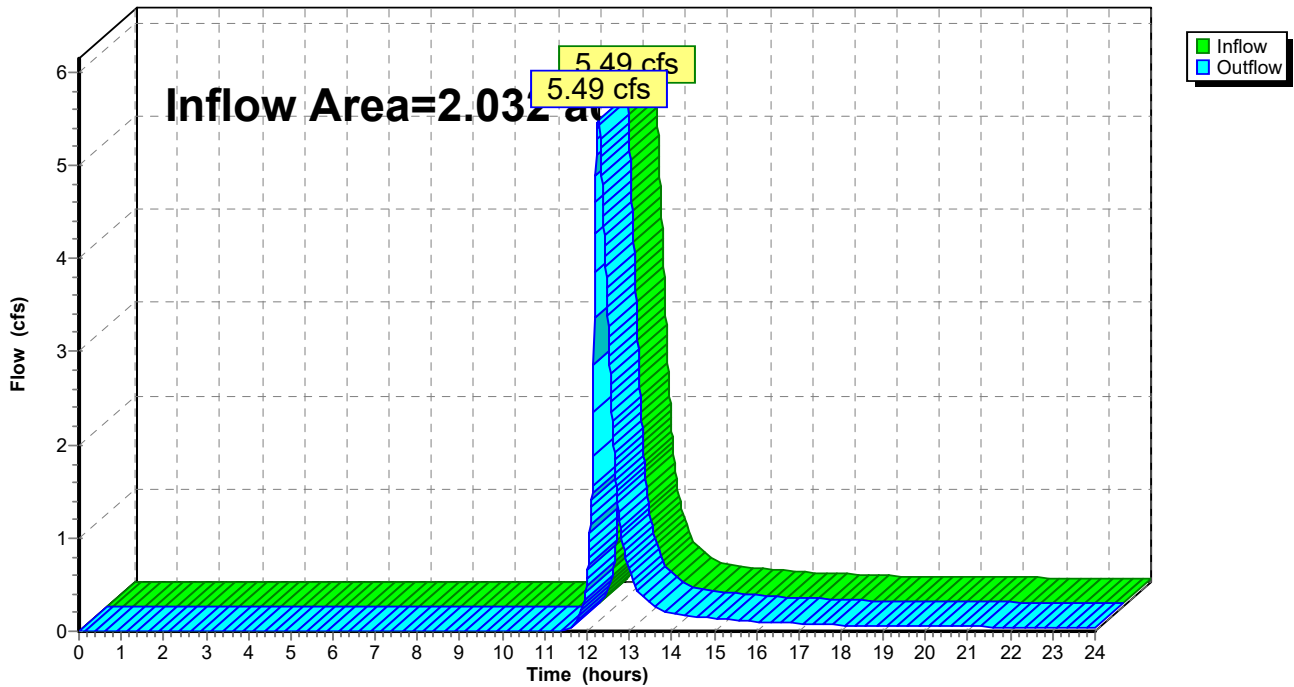

### Summary for Reach R2: Reach 2

Inflow Area = 0.020 ac, 0.00% Impervious, Inflow Depth > 5.49" for 100-Year event  
Inflow = 0.13 cfs @ 12.07 hrs, Volume= 0.009 af  
Outflow = 0.13 cfs @ 12.07 hrs, Volume= 0.009 af, Atten= 0%, Lag= 0.0 min

Routing by Stor-Ind+Trans method, Time Span= 0.00-24.00 hrs, dt= 0.01 hrs

### Reach R2: Reach 2

Hydrograph

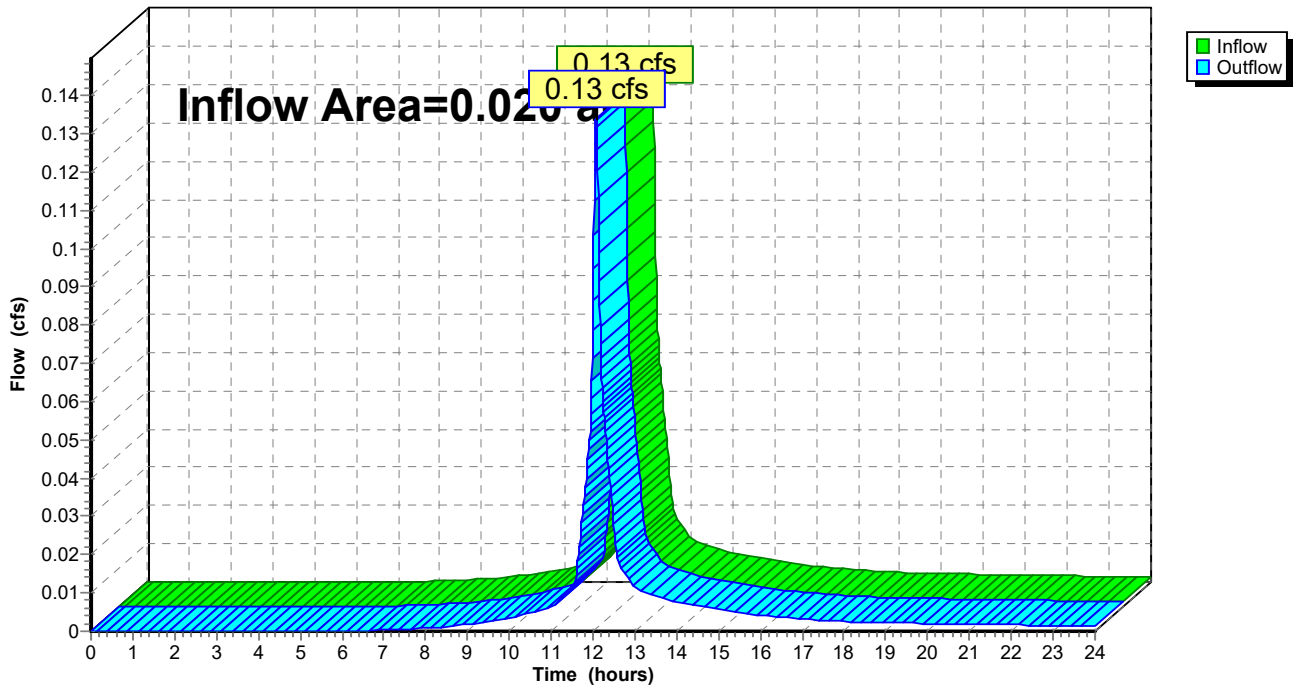

# 2023-03-10\_POST-DRAINAGE

Prepared by {enter your company name here}

HydroCAD® 10.10-3a s/n 11112 © 2020 HydroCAD Software Solutions LLC

Post Construction Runoff

Type III 24-hr 100-Year Rainfall=8.24"

Printed 6/20/2023

Page 32

## Summary for Pond PR1: Recharge 1

Inflow Area = 1.192 ac, 37.82% Impervious, Inflow Depth > 5.96" for 100-Year event  
Inflow = 6.84 cfs @ 12.15 hrs, Volume= 0.592 af  
Outflow = 4.87 cfs @ 12.28 hrs, Volume= 0.585 af, Atten= 29%, Lag= 7.4 min  
Discarded = 0.70 cfs @ 12.28 hrs, Volume= 0.435 af  
Primary = 4.18 cfs @ 12.28 hrs, Volume= 0.150 af

Routing by Stor-Ind method, Time Span= 0.00-24.00 hrs, dt= 0.01 hrs  
Peak Elev= 107.20' @ 12.28 hrs Surf.Area= 3,636 sf Storage= 7,269 cf

Plug-Flow detention time= 92.7 min calculated for 0.585 af (99% of inflow)  
Center-of-Mass det. time= 85.7 min ( 889.0 - 803.3 )

Volume	Invert	Avail.Storage	Storage Description
#1	103.00'	10,735 cf	<b>Custom Stage Data (Prismatic)</b> Listed below (Recalc)
Elevation (feet)	Surf.Area (sq-ft)	Inc.Store (cubic-feet)	Cum.Store (cubic-feet)
103.00	380	0	0
104.00	870	625	625
105.00	1,530	1,200	1,825
106.00	2,345	1,938	3,763
107.00	3,300	2,823	6,585
108.00	5,000	4,150	10,735

Device	Routing	Invert	Outlet Devices
#1	Discarded	103.00'	<b>8.270 in/hr Exfiltration over Surface area</b>
#2	Primary	106.75'	<b>5.0' long (Profile 5) Broad-Crested Rectangular Weir</b> Head (feet) 0.49 0.98 1.48 Coef. (English) 2.79 2.93 3.06

**Discarded OutFlow** Max=0.70 cfs @ 12.28 hrs HW=107.20' (Free Discharge)

↑**1=Exfiltration** (Exfiltration Controls 0.70 cfs)

**Primary OutFlow** Max=4.17 cfs @ 12.28 hrs HW=107.20' (Free Discharge)

↑**2=Broad-Crested Rectangular Weir** (Weir Controls 4.17 cfs @ 1.87 fps)



**2023-03-10\_POST-DRAINAGE**

Prepared by {enter your company name here}

HydroCAD® 10.10-3a s/n 11112 © 2020 HydroCAD Software Solutions LLC

Post Construction Runoff  
Type III 24-hr 100-Year Rainfall=8.24"

Printed 6/20/2023

Page 33

**Pond PR1: Recharge 1**

Hydrograph

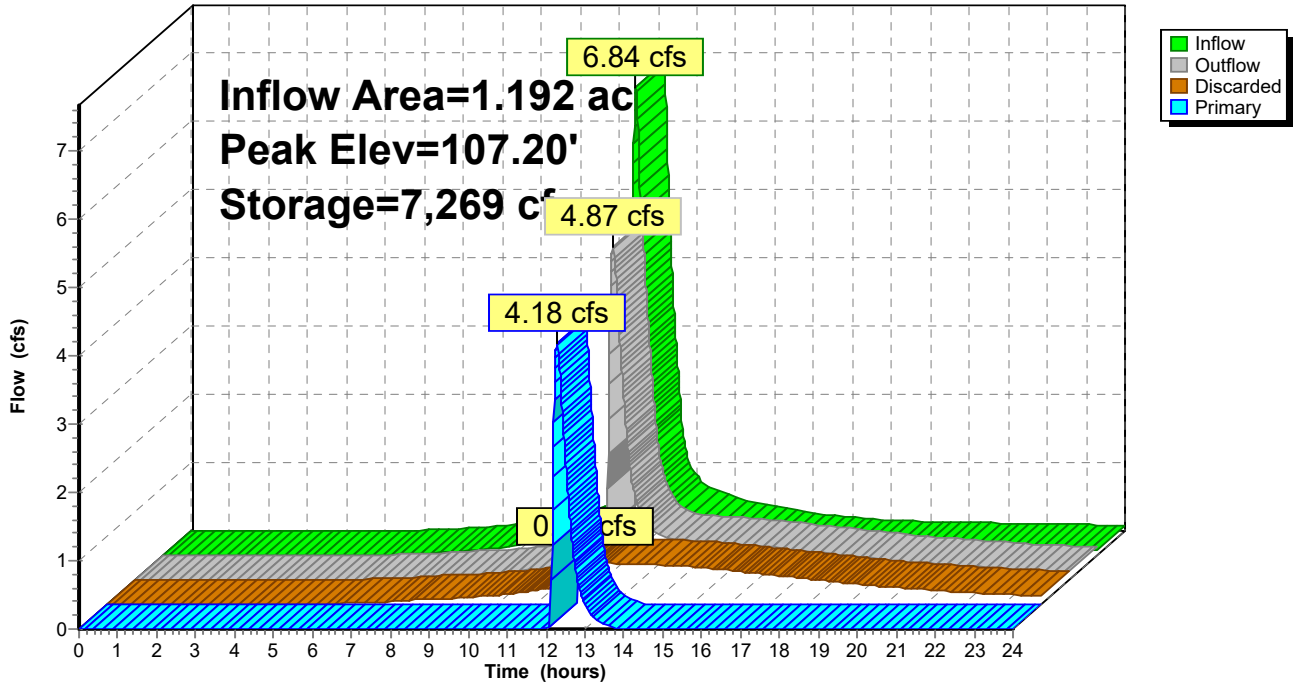

June 20, 2023

To: Mary Benedetto, Senior Planner  
Reading Town Hall  
16 Lowell Street, Town Hall  
Reading, MA 01867

**RE: DEFINITIVE SUBDIVISION – GRANDVIEW ROAD EXTENSION  
REVISION COMMENTS  
GRANDVIEW ROAD EXTENSION  
READING, MA 01867**

To Ms. Benedetto,

We have reviewed the comments provided by the CPDC and Engineering Division in regards to the the Major Modification of a Definitive Subdivision known as Grandview Road. Comments and associated responses by Fodera Engineering (FE) follows:

**Email from Mary Benedetto on 5/17/2023**

CPDC had the following asks:

- A response to the Engineering memo, both written comments and plan changes alike. Please reference/detail any plan changes within the memo.  
*FE Response: No comment.*
  
- The plan revised to directly address the following:
  - Addition of a treatment forebay to the drainage design  
*FE Response: Sediment forebay added.*
  
  - Lot 4 drainage pipe design so as to not discharge into Lot 3 or the proposed sidewalk.  
*FE Response: Roof runoff pipe from Lot 4 has been revised to enter directly into the drain manhole rather than daylighting to the sidewalk.*
  
  - Rip-rap design location being so near to the property line and ensure DEP requirements are met. Please provide further explanation on all overflow discharging to this area.  
*FE Response: The rip-rap outfall has been removed along with this point of discharge. Previously, the point of discharge was added to control peak rate of runoff and have it reduced compared to existing conditions. Although having the point of discharge and rip-rap outfall was satisfactory with it in place, we further determined that it was not needed in this case. The detention pond's overflow weir is satisfactory alone. Peak*

*rates of runoff are reduced in the post-construction conditions. Peak rates of runoff in cubic-feet per second (cfs) directed to the northeast (Reach 1) are as follows:*

	<u>Pre</u>	<u>Post</u>
<i>2-Year</i>	<i>0.24</i>	<i>0.01</i>
<i>10-Year</i>	<i>1.40</i>	<i>0.32</i>
<i>25-Year</i>	<i>2.38</i>	<i>2.05</i>

- The drainage design and calculations should include the future home on Lot 2  
*FE Response: Drainage design includes the future driveway and walkways of lot 2. It does not include roof runoff, which will need its own separate dry-well system as outlined on the plan set.*
- Please provide further TSS/Phosphorus calculations  
*FE Response: Provided herewith. TSS pre-treatment removal is 44%. TSS treatment removal is 89%. Phosphorous removal is almost 84%.*
- Can the lot lines of Lot 1 and Lot 2 be modified to remove the need for an easement to keep the shed?  
*FE Response: Property lines have been adjusted and the shed is now fully within the limits of Lot 1.*
- Provide more information or detail on the Lot 4 retaining wall. Is an easement required to ensure adequate build? If so, please provide a draft and likely a condition will be placed to receive a copy of the executed easement prior to permitting.  
*FE Response: We revised the retaining wall from a 6' high wall to two (2) tiered 3' high walls. A 3' high wall will not need structural design nor would it require extending into the abutting property.*
- Further justification for the proposed waiver or a revision to the design for further clearance  
*FE Response: We revised the plans to omit the need for a waiver on drainage pipe cover. Section 7.4.4.3e states that storm drain pipes shall have a minimum of four (4) feet of cover in paved or other vehicular roads and a minimum of three (3) feet of cover in easements. The drain pipe is located at the end of the cul-de-sac that is directed to the sediment forebay. There is no section of pipe that falls under a "paved or other vehicular roads" area. The section of pipe within the drainage easement has three (3) feet of cover with the addition of a headwall at the pipe outlet into the sediment forebay.*
- The design and calculations meet the stormwater permit requirements.  
*FE Response: No comment.*

**Memorandum from Engineering Division, Alex Rozycki P.E., dated April 27, 2023**

- Previous plans for the southernmost home included roof drainage tied into the infiltration system, there are concerns that the adjacent property will now receive stormwater flows given the grades. The stormwater report indicates all impervious areas will be captured, does that include hardscapes on the lots? The previous plan captured impervious areas on individual lots.  
***FE Response: Roof runoff from the southernmost house will now be tied directly into the drainage conveyance system and detention pond.***
- The infiltration chamber design under the endorsed plans will allow for more land use in the backyard areas, the proposed detention pond design eliminates the use of land.  
***FE Response: A detention pond is a common and accepted method for managing stormwater. There are still backyard areas provided to each new dwelling.***
- Engineering sees no reason to support the waiver allowing less cover on utilities, there appears to be no benefit to support such a waiver.  
***FE Response: The site has been redesigned to omit the need for a waiver from Section 7.4.4.3e of the subdivision rules and regulations.***
- The Engineering Department does not approve of gas lines or electrical services, those shall be coordinated and approved by others.  
***FE Response: Gas and electric utilities will be coordinated with the respective utility companies/ departments.***
- There are many instances of utilities crossing, we are particularly concerned with the crossing of water and sewer. Crossings should be limited, and invert elevations of the services may be requested to ensure proper separation.  
***FE Response: We limited crossings of utilities but it is inevitable that crossings will occur. There is a “Water Main Crossing” detail on sheet C-6.***
- Inverts of the existing sewer manhole should be provided, as well as a detail for the force main connection.  
***FE Response: Invert of the existing sewer manhole was provided by the surveyor and is INV=112.4. Details associated with the force main are on sheet C-6.***
- MaDEP regulations may not allow for discharge of water or overflow rip-rap within 10 feet of a property line.  
***FE Response: The overflow rip-rap has been removed as determined was unnecessary.***
- NPDES MS4 permit requirements shall be met for TSS removal and Phosphorous reduction. The supporting calculations should be provided and reviewed by Engineering. The project will also require a Storm Water Pollution Prevention Plan as well as an O&M plan for the proposed detention basin.

*FE Response: TSS removal and Phosphorous reduction is provided herewith. A Storm Water Pollution Prevention Plan (SWPPP) will be provided prior to construction. An O&M plan is outlined in the Stormwater Management Report dated March 10, 2023.*

- A Sewer Connection I/I fee is required.  
*FE Response: That will be paid for prior to construction.*
- The driveway curb cuts shall meet Town of Reading standard cross sections. The proposed elevations are unclear in these areas, all driveways will be approved individually.  
*FE Response: Proposed spot grade elevations at driveway curb cuts are shown on sheet C-4. A detail labeled "Typical Driveway Apron" is provided on sheet C-7.*
- All utilities shall be approved materials and installed in accordance with the Department of Public Works Standards.  
*FE Response: All utilities proposed are in accordance with the Department of Public Works Standards.*
- Engineering Division shall be notified 72 hours in advance to mark out Town utilities.  
*FE Response: This will be completed.*
- All water, sewer, curb cut, street opening and Jackie's Law excavation permits shall be obtained at the Engineering Division prior to any excavations.  
*FE Response: This will be completed.*
- All site work shall be inspected by the Engineering Division. The Applicant/Owner's contractor shall submit a construction schedule of proposed work. All inspections shall be scheduled 48 hours in advance.  
*FE Response: This will be submitted.*
- An approved site as-built shall be submitted to the Engineering Division within 60 days of certificate of occupancy. The as-built shall be submitted in mylar and electronic ACAD format.  
*FE Response: This will be submitted.*

Please accept this memorandum as a summary of responses and do not hesitate to call or email me shall you have any questions, comments, or concerns.



Giovanni G. Fodera, P.E.

Principal Engineer

**FODERA Engineering**

28 Harbor St., Suite 204

Danvers, MA 01923



Project: 4-Lot Subdivision  
 Address 4 Cold Spring Road  
 Calculated By: Giovanni G. Fodera, P.E.  
 Date: 6/20/2023

Standard 4 in the Massachusetts Stormwater Handbook, completed in accordance with 310 CMR 10.00 and 314 CMR 9.00

**WATER QUALITY CALCULATIONS, TSS REMOVAL**

Runoff from impervious surfaces flow overland and gather solids as the stormwater is directed into conveyance systems, and can have adverse effects to water pollution. Standard 4 was implemented for stormwater management systems to be designed to remove 80% of the average annual post-development load of Total Suspended Solids (TSS). Runoff volume requiring appropriate TSS treatment is known as the required water quality volume.

- Treatment Train 1:**
1. Catch Basin with Deep Sump & Hood
  2. Manhole with Deep Sump & Hood
  3. Infiltration Basin with Sediment Forebay

Pretreatment BMP	B TSS Removal Rate	C Starting TSS Load	D Amount Removed (BxC)	E Remaining Load (C-D)	F TSS Removal Rate
Deep Sump and Hooded Catch Basin	0.25	1.00	0.25	0.75	25%
Deep Sump and Hooded Catch Basin	0.25	0.75	0.19	0.56	44%

Treatment BMP	B TSS Removal Rate	C Starting TSS Load	D Amount Removed (BxC)	E Remaining Load (C-D)	F TSS Removal Rate
Infiltration Basin w/ Sediment Forebay	0.80	0.56	0.45	0.11	89%

Pretreatment TSS Removal =	44%	(standard is met)
Treatment TSS Removal =	89%	(standard is met)

Note: Roof runoff does not require pretreatment

1. Management Objective			
Select Pollutant Type ->	TP	Total BMP Cost (\$)	\$37,178
Enter Target Load Reduction (%) ->	60.0%	Total Pollutant Load Reduction (%)	83.9%

2. Optimization Target			
Select an option ->	BMP Storage Capacity	Total BMP Storage Capacity (gal)	11,133

3. Watershed Information			
Enter Land Use Area ->	<a href="#">Click Here</a>	Total Impervious Area (ac)	0.4

4. BMP Information			
Enter Drainage Area ->	<a href="#">Click Here</a>	Total Treated Impervious Area (ac)	0.4

5. Optimal Solution						
BMP Type	Design Storage Capacity (ft <sup>3</sup> )	BMP Cost (\$)	Treated Impervious Area (ac)	O&M (hr/yr)	Load Reduction (lbs)	Treated Runoff Depth (in)
Biofiltration with ISR	-	\$ -	-	-	-	-
Bioretention	-	\$ -	-	-	-	-
Dry Pond	-	\$ -	-	-	-	-
Grass Swale*	-	\$ -	-	-	-	-
Gravel Wetland	-	\$ -	-	-	-	-
Infiltration Basin	-	\$ -	-	-	-	-
Infiltration Chambers*	-	\$ -	-	-	-	-
Infiltration Trench	1,488	\$ 37,178	0.41	-	0.79	1.00
Porous Pavement*	-	\$ -	-	-	-	-
Sand Filter	-	\$ -	-	-	-	-
Wet Pond	-	\$ -	-	-	-	-

Note: Only fill in the yellow highlighted cells.

\* Place holder for future option (not implemented)

## Planning Level Analysis

The purpose of this tool is to provide decision-makers a comprehensive overview of stormwater management opportunities in a given watershed. The tool will characterize the watershed characteristics and opportunities for applying a variety of BMP technologies to various source areas based on land use, soils, and impervious cover. There are two approaches of the planning-level analysis tool:

- 1: BMP Storage Capacity** – to evaluate the changes in hydrologic and water quality benefits as the BMP/LID sizes are increased in fixed increments; and
- 2: BMP Drainage Area** – to determine how much impervious area would require treatment if specified BMP design capacities are selected for each HRU type to be treated.

[Run Single Scenario](#)

[Run Optimize Scenario](#)

[Return to Home Page](#)





**LEGEND**

- ⊕ BM # BENCHMARK
- ▣ BOUND (CONC. STONE, LAND COURT, ETC.)
- ▣ CB CATCH BASIN - SQUARE
- ⊕ CB CATCH BASIN - ROUND
- ⊙ DSK DISK (CAVT. USC&GS, LAND COURT, ETC.)
- ⊙ DH DRILL HOLE
- ⊙ DMH DRAIN MANHOLE
- ⊙ EHH ELECTRIC HANDHOLE
- ⊙ EM ELECTRIC MANHOLE
- ⊙ EM ELECTRIC METER
- ⊙ GG GAS GATE
- ⊙ GM GAS METER
- ♿ HANDICAP SYMBOL
- ⊙ GUY WIRE ANCHOR
- ⊙ FIRE HYDRANT
- ☀ LIGHT
- OHW OVERHEAD WIRE
- ⊙ MAG MAG NAIL
- ⊙ MB MAIL BOX
- ⊙ OTHER MANHOLE
- ⊙ PB PULL BOX
- ⊙ PED PEDESTRIAN SIGNAL
- ⊙ SEWER MANHOLE
- ⊙ TELEPHONE MANHOLE
- ⊙ TRANSFORMER
- ⊙ # OF PARKING SPACES
- ⊙ TS TRAFFIC SIGNAL
- ⊙ TS TRAFFIC SIGNAL MAST ARM/SPAN WIRE POLE SIGN
- ⊙ ULT# UTILITY POLE W/ LIGHT
- ⊙ UPL# UTILITY POLE
- ⊙ WG WATER GATE
- ⊙ WSO WATER SHUTOFF
- CHAIN LINK FENCE
- WOOD FENCE

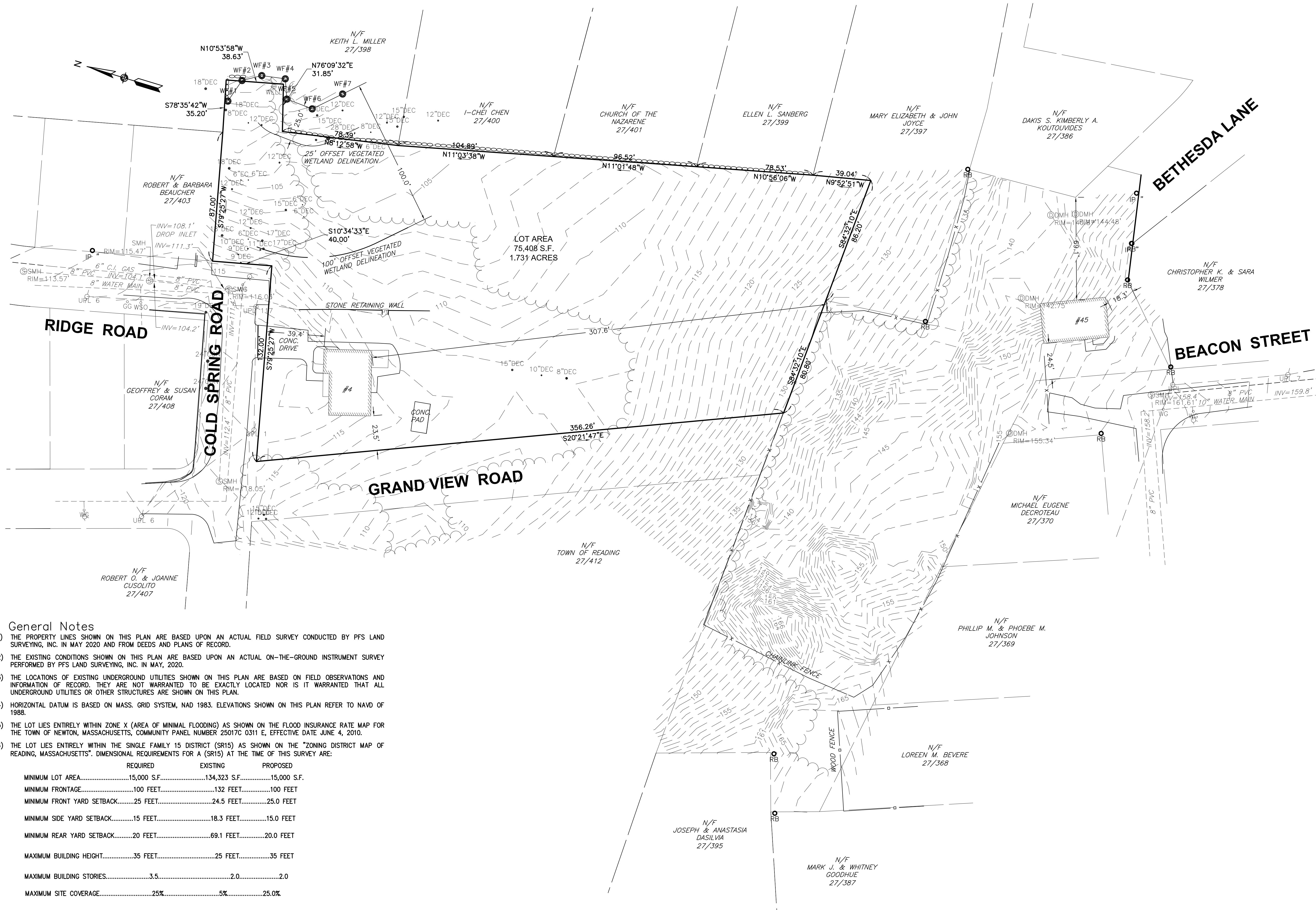

**General Notes**

- 1) THE PROPERTY LINES SHOWN ON THIS PLAN ARE BASED UPON AN ACTUAL FIELD SURVEY CONDUCTED BY PFS LAND SURVEYING, INC. IN MAY 2020 AND FROM DEEDS AND PLANS OF RECORD.
- 2) THE EXISTING CONDITIONS SHOWN ON THIS PLAN ARE BASED UPON AN ACTUAL ON-THE-GROUND INSTRUMENT SURVEY PERFORMED BY PFS LAND SURVEYING, INC. IN MAY, 2020.
- 3) THE LOCATIONS OF EXISTING UNDERGROUND UTILITIES SHOWN ON THIS PLAN ARE BASED ON FIELD OBSERVATIONS AND INFORMATION OF RECORD. THEY ARE NOT WARRANTED TO BE EXACTLY LOCATED NOR IS IT WARRANTED THAT ALL UNDERGROUND UTILITIES OR OTHER STRUCTURES ARE SHOWN ON THIS PLAN.
- 4) HORIZONTAL DATUM IS BASED ON MASS. GRID SYSTEM, NAD 1983. ELEVATIONS SHOWN ON THIS PLAN REFER TO NAVD OF 1988.
- 5) THE LOT LIES ENTIRELY WITHIN ZONE X (AREA OF MINIMAL FLOODING) AS SHOWN ON THE FLOOD INSURANCE RATE MAP FOR THE TOWN OF NEWTON, MASSACHUSETTS, COMMUNITY PANEL NUMBER 25017C 0311 E, EFFECTIVE DATE JUNE 4, 2010.
- 6) THE LOT LIES ENTIRELY WITHIN THE SINGLE FAMILY 15 DISTRICT (SR15) AS SHOWN ON THE "ZONING DISTRICT MAP OF READING, MASSACHUSETTS". DIMENSIONAL REQUIREMENTS FOR A (SR15) AT THE TIME OF THIS SURVEY ARE:

	REQUIRED	EXISTING	PROPOSED
MINIMUM LOT AREA.....	15,000 S.F.	134,323 S.F.	15,000 S.F.
MINIMUM FRONTAGE.....	100 FEET	132 FEET	100 FEET
MINIMUM FRONT YARD SETBACK.....	25 FEET	24.5 FEET	25.0 FEET
MINIMUM SIDE YARD SETBACK.....	15 FEET	18.3 FEET	15.0 FEET
MINIMUM REAR YARD SETBACK.....	20 FEET	69.1 FEET	20.0 FEET
MAXIMUM BUILDING HEIGHT.....	35 FEET	25 FEET	35 FEET
MAXIMUM BUILDING STORIES.....	3.5	2.0	2.0
MAXIMUM SITE COVERAGE.....	25%	5%	25.0%

- 7) THE WETLANDS SHOWN HEREON WERE FLAGGED BY LEC ENVIRONMENTAL IN JUNE 2020 AND LOCATED BY PFS LAND SURVEYING INC, IN JUNE 2020.

No.	Revision	Date	Apprv.
2	added tree locations in buffer zone	2-04-2021	BGP
1	updated well location	12-09-2020	BGP

Designed by BGP Drawn by BGP Checked by BGP  
 CAD checked by BGP Approved by BGP  
 Scale 1"=30' Date 7/8/2020

Existing Conditions  
4 Cold Spring Rd  
Reading, MA

Issued for  
Review

Drawing Title  
Existing Conditions  
Plan of Land

Drawing Number  
**SV-1**

Sheet  
1 of 1

Project Number

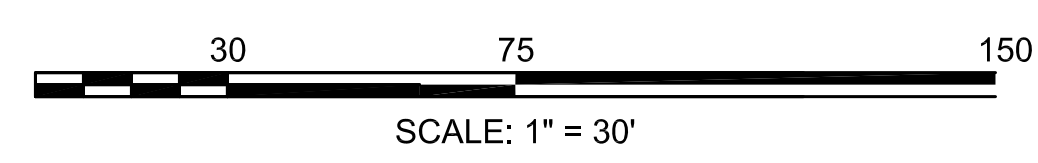

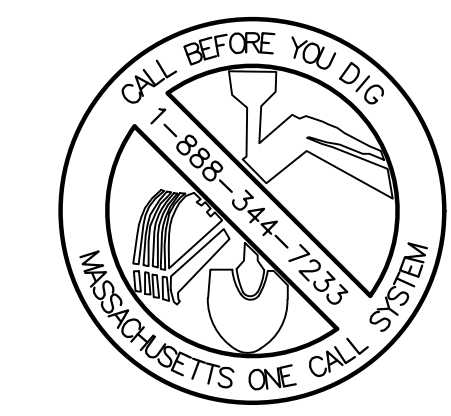

REVISION	DATE	BY

PROJECT LOCATION:  
 LOTS 2, 3, & 4  
 GRANDVIEW ROAD  
 READING, MA 01867  
 PARCEL ID:  
 MAP 27, LOT 404

PLAN SET:  
**MAJOR SITE PLAN MODIFICATION**  
**GRANDVIEW ROAD SUBDIVISION - PRIVATE WAY**  
**(GRANDVIEW ROAD EXTENSION)**  
 APRIL 20, 2023  
 SCALE: 1" = 20'

N/F  
 MARY ELIZABETH & JOHN  
 JOYCE  
 27/397

**RIGHT-OF-WAY STATEMENT**

THE RIGHT-OF-WAY (ROW), SOUTH OF THE INTERSECTION FROM COLD SPRING ROAD AND GRANDVIEW ROAD, IS AS A PRIVATE WAY FOR ALL LAND OWNERS IN AND ABUTTING THE SUBDIVISION, AND WILL REMAIN NAMED AS GRANDVIEW ROAD.

**LEGEND**

- PROPERTY LINE
- - - EASEMENT LINE
- - - WETLAND BOUNDARY
- RADIUS MEASUREMENT
- WETLAND FLAG
- STONE BOUND WITH DRILL HOLE

**GENERAL NOTES**

- WETLANDS WERE FLAGGED BY LEC ENVIRONMENTAL CONSULTANTS IN JUNE 2020.
- THE PROJECT IS LOCATED OUTSIDE OF ANY PROTECTED RESOURCE AREAS AND FLOOD ZONES AS DETERMINED BY THE MOST RECENTLY PUBLISHED DATA FROM THE MASSACHUSETTS DEPARTMENT OF ENVIRONMENTAL PROTECTION AND FEMA.
- IN LIEU OF A RETAINING WALL LOCATED IN THE RIGHT-OF-WAY ALONG THE WESTERN BOUNDARY OF GRANDVIEW ROAD, A TEMPORARY THIRTY (30) FOOT WIDE SLOPE EASEMENT IS PROPOSED ON TOWN PROPERTY AND SHALL BE APPROVED BY THE TOWN. SEE SHEET C-5 FOR GRADING.

**PLAN REFERENCES**

- BOUNDARY, TOPOGRAPHIC, AND PLANIMETRIC INFORMATION WAS OBTAINED FROM AN ON-THE-GROUND SURVEY PERFORMED AND COMPLETED BY PFS LAND SURVEYING.

**PROPERTY INFORMATION**

ADDRESS: LOTS 2, 3, & 4  
 GRANDVIEW ROAD EXTENSION  
 READING, MA 01867  
 TAX MAP, LOT: PART OF MAP 27, LOT 404  
 LOT SIZE: 45,132 S.F. (1.04 AC.)

**RECORD OWNERS**

LOTS 2, 3, & 4  
 GRANDVIEW, LLC  
 45 BEACON STREET  
 READING, MA 01867

**APPLICANT**

MICHAEL SALAMONE  
 45 BEACON ST.  
 READING, MA 01867

**ZONING SUMMARY**

ZONING DISTRICT: SINGLE FAMILY 15 (S15)

	REQUIRED	LOT 1	LOT 2	LOT 3	LOT 4
MIN. LOT WIDTH	60'	>60'	>60'	>60'	>60'
MIN. LOT AREA (SF)	15,000	22,112	15,002	15,026	15,104
MIN. FRONTAGE	100'	132.00'	151.62'	100.00'	100.00'
RELIEF REQUIRED	-	N	N	N	N

TOWN OF READING  
 COMMUNITY PLANNING & DEVELOPMENT COMMISSION

DATE: \_\_\_\_\_  
 \_\_\_\_\_  
 \_\_\_\_\_  
 \_\_\_\_\_

FOR REGISTRY USE ONLY

**ENGINEER:**

**FODERA ENGINEERING**  
 (617)877-3293  
 gfodera@foderaengineering.com  
 28 Harbor St., Suite 204  
 Danvers, MA 01923

PROFESSIONAL SEAL



**SURVEYOR:**

**PFS Land Surveying, Inc.**  
 30 Bulch Avenue  
 Groveland, MA 01834  
 P.978.891.5203  
 www.pfsland.com

PROFESSIONAL SEAL

**COPYRIGHT NOTICE**  
 This drawing is property of Fodera Engineering and is not to be used for any purpose other than the specific project and site named herein, and cannot be reproduced in any manner without the express written permission from the engineer on record.

JOB NO.: 20160-149

SHEET TITLE:  
**PLAN OF LAND**

SHEET NUMBER:  
**C-1**

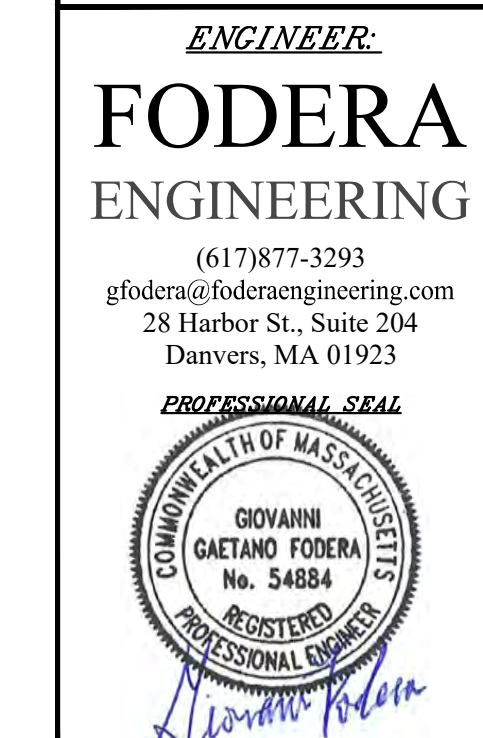
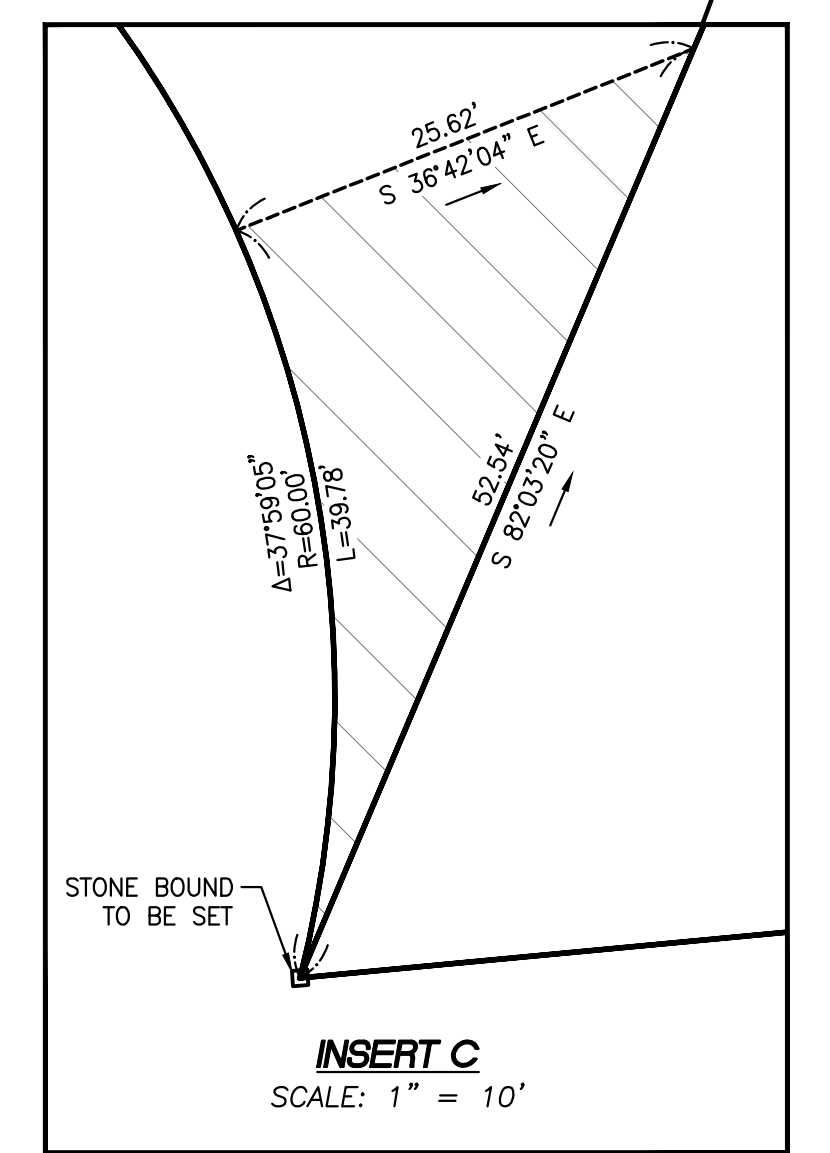
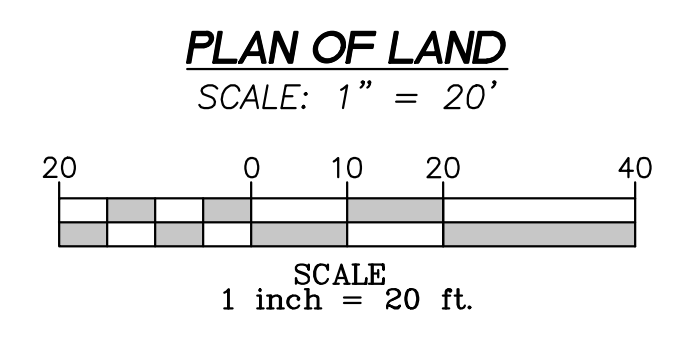
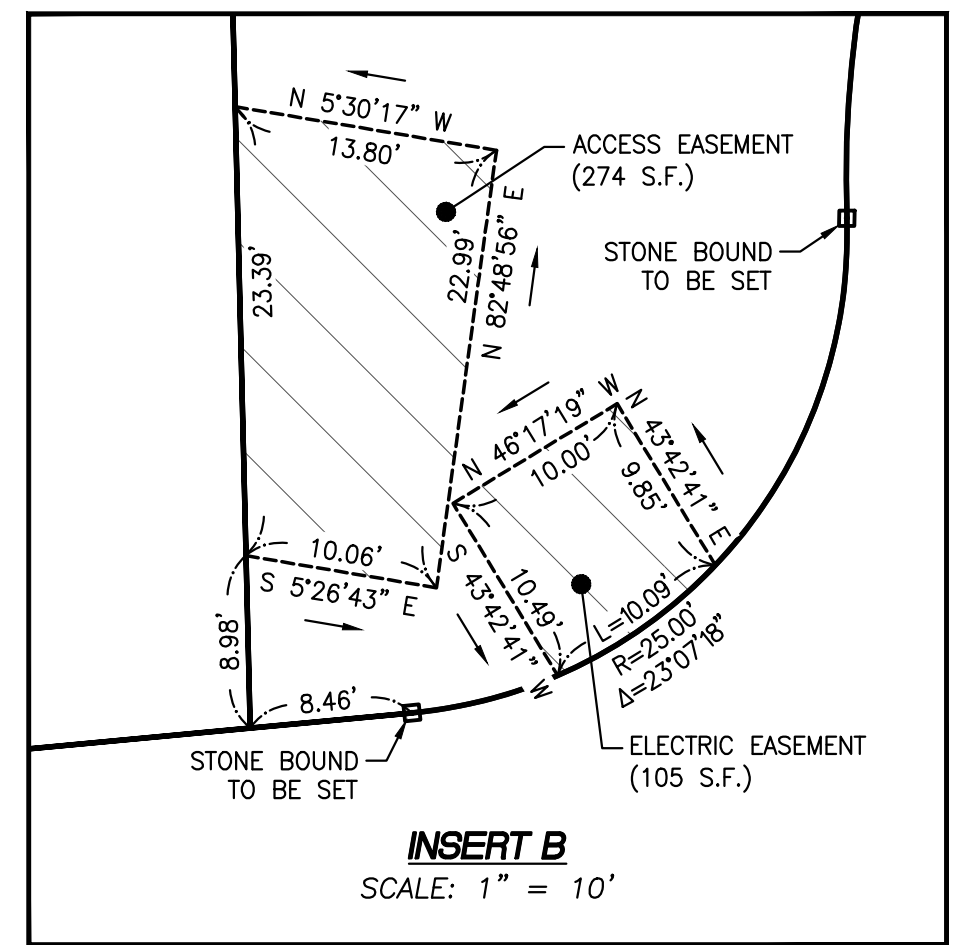
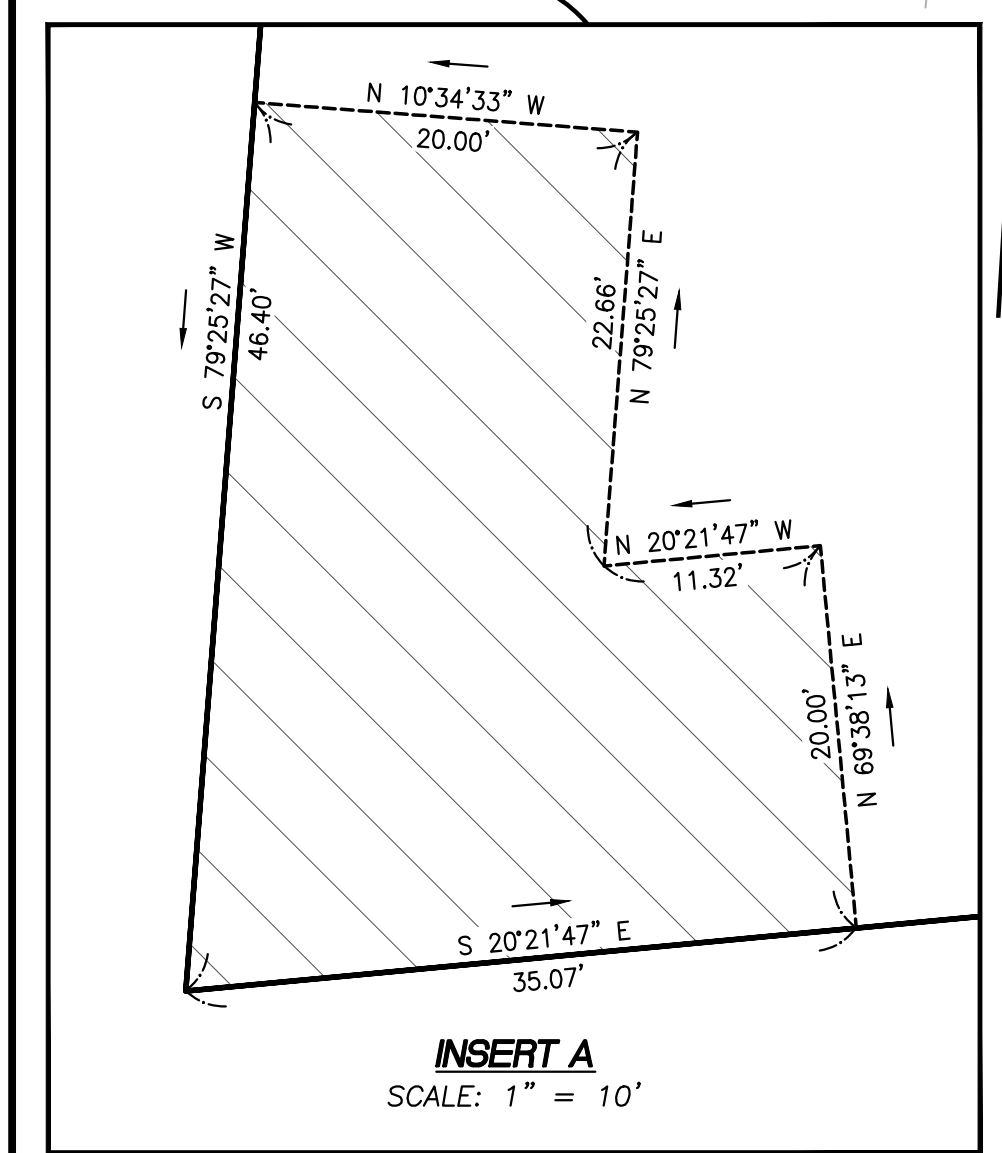
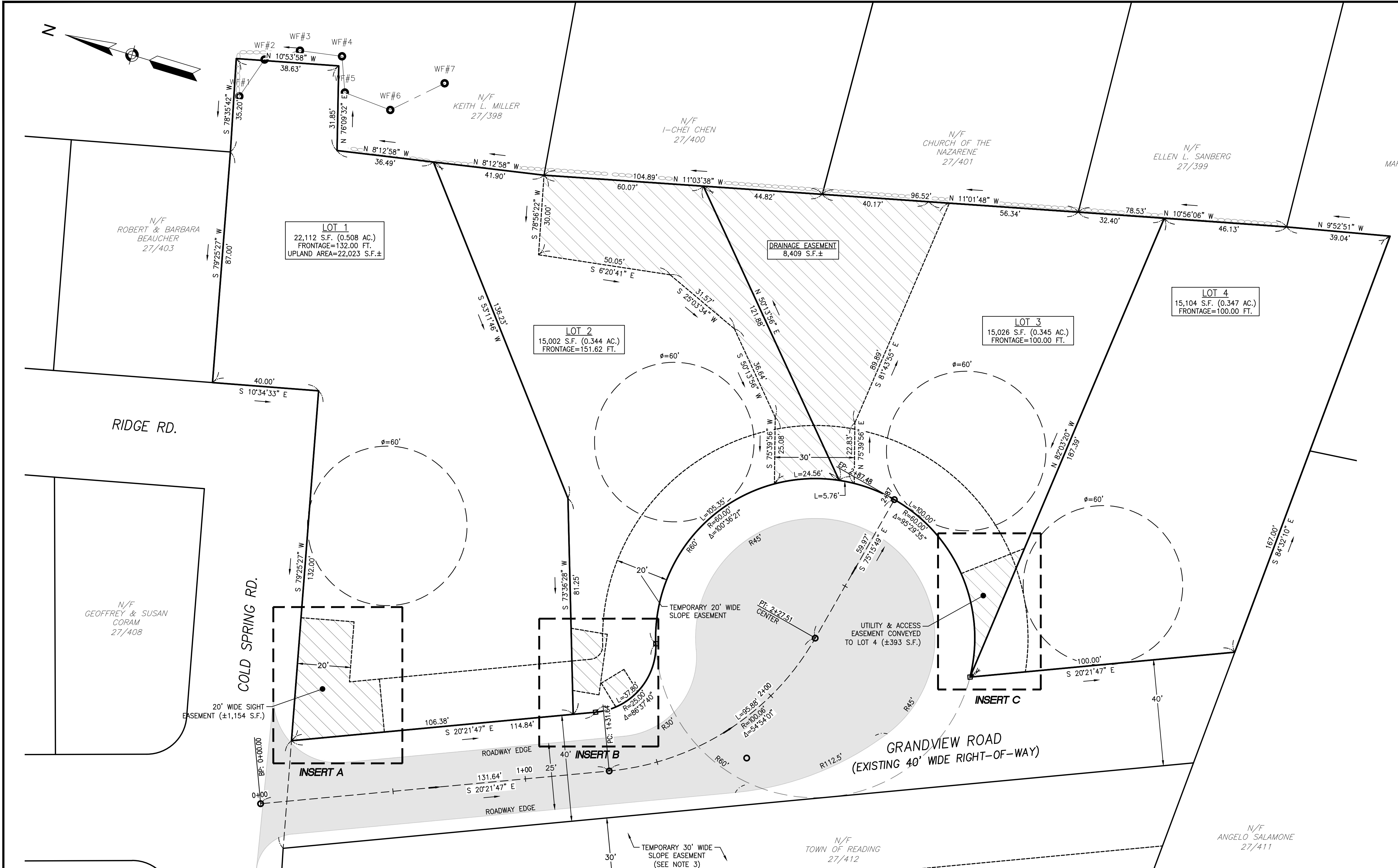

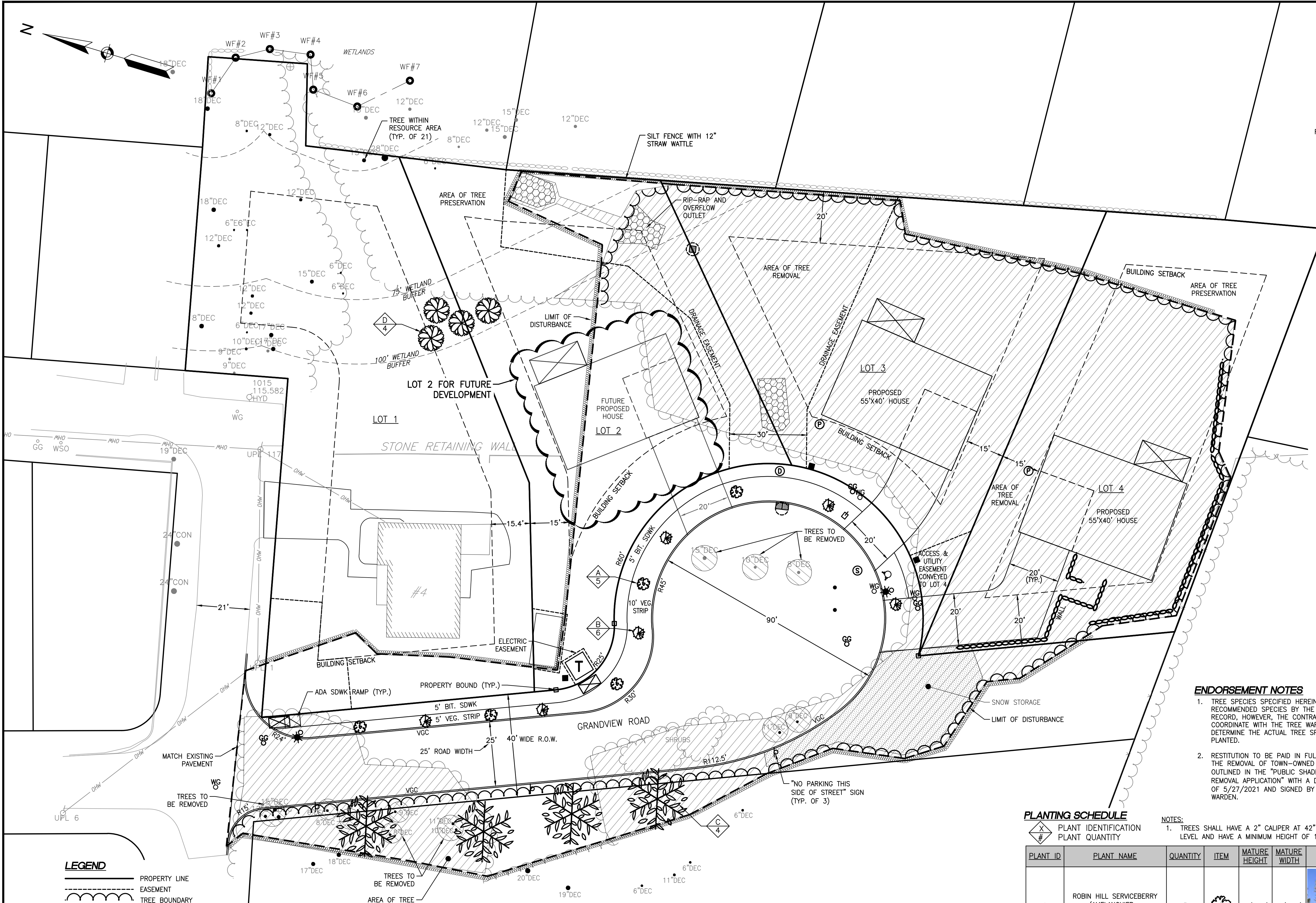

- LEGEND**
- PROPERTY LINE
  - - - EASEMENT
  - TREE BOUNDARY
  - SNOW STORAGE AREA
  - RIP-RAP
  - TREE REMOVAL AREA
  - RETAINING WALL
  - BUILDING SETBACK
  - LIMIT OF DISTURBANCE
  - WETLAND BOUNDARY
  - WETLAND BUFFER
  - WF# WETLAND FLAG
  - VGC VERTICAL GRANITE CURB
  - MB MAILBOX
  - SP SEWER PUMP
  - FM FORCE MAIN FLUSHING GATE
  - FS FORCE SERVICE BALL VALVE
  - CB CATCH BASIN
  - DMH DRAIN MANHOLE
  - OOS OVERFLOW OUTLET STRUCTURE
  - WG WATER VALVE
  - GS GAS VALVE
  - T ELECTRIC TRANSFORMER & EASEMENT
  - ES ELECTRIC SERVICE PULLBOX
  - EM ELECTRIC MANHOLE

**TREE PRESERVATION CALCULATIONS**

	LOT 1	LOT 2	LOT 3	LOT 4	Grand View Rd.	TOTALS
LOT AREA, S.F.	22,112	15,002	15,026	15,104	22,164	89,408
NEW IMPERVIOUS, S.F.	0	2,388	2,526	2,998	12,572	23,549
SUM: OPEN SPACE, S.F.	*19,047	12,614	12,500	12,106	9,592	65,859
**REQUIRED # OF TREES	10	7	7	7	N/A	31
AREA OF TREE REMOVAL, S.F.	0	3,605	13,325	11,140	6,217	34,287
AREA OF TREE PRESERVED, S.F.	7,948	3,260	1,590	3,970	2,832	19,600
**ESTIMATED # OF TREES PRESERVED	20	14	7	17	12	70

**TREE INVENTORY WITHIN WETLAND BUFFER ZONE**

	TREE COUNT
EXISTING TREE COUNT	21
TREES TO BE REMOVED	0
TOTAL TREES TO REMAIN	21

**PERMANENT GRASS SEED MIX**

LITTLE BLUESTEM OR BROOMSEDGE	0.25
TUMBLE LOVEGRASS	0.10
SWITCHGRASS	0.10
BUSH CLOVER	0.10
RED TOP	0.10

**PLANTING SCHEDULE**

PLANT ID	PLANT NAME	QUANTITY	ITEM	MATURE HEIGHT	MATURE WIDTH	IMAGE
A	ROBIN HILL SERVICEBERRY (AMELANCHIER x GRANDIFLORA 'ROBIN HILL')	5		15'-25'	12'-15'	
B	GOLDSPIRE GINKGO (GINKGO BILOBA 'GOLDSPIRE')	6		15'	5'-6'	
*C	SUGAR MAPLE TREE (ACER SACCHARUM)	4		60'-75'	40'-50'	
D	HIGHBUSH BLUEBERRY (VACCINIUM CORYMBOSUM)	4		6'-12'	8'-12'	

NOTES:  
1. TREES SHALL HAVE A 2" CALIPER AT 42" FROM GROUND LEVEL AND HAVE A MINIMUM HEIGHT OF 12'.

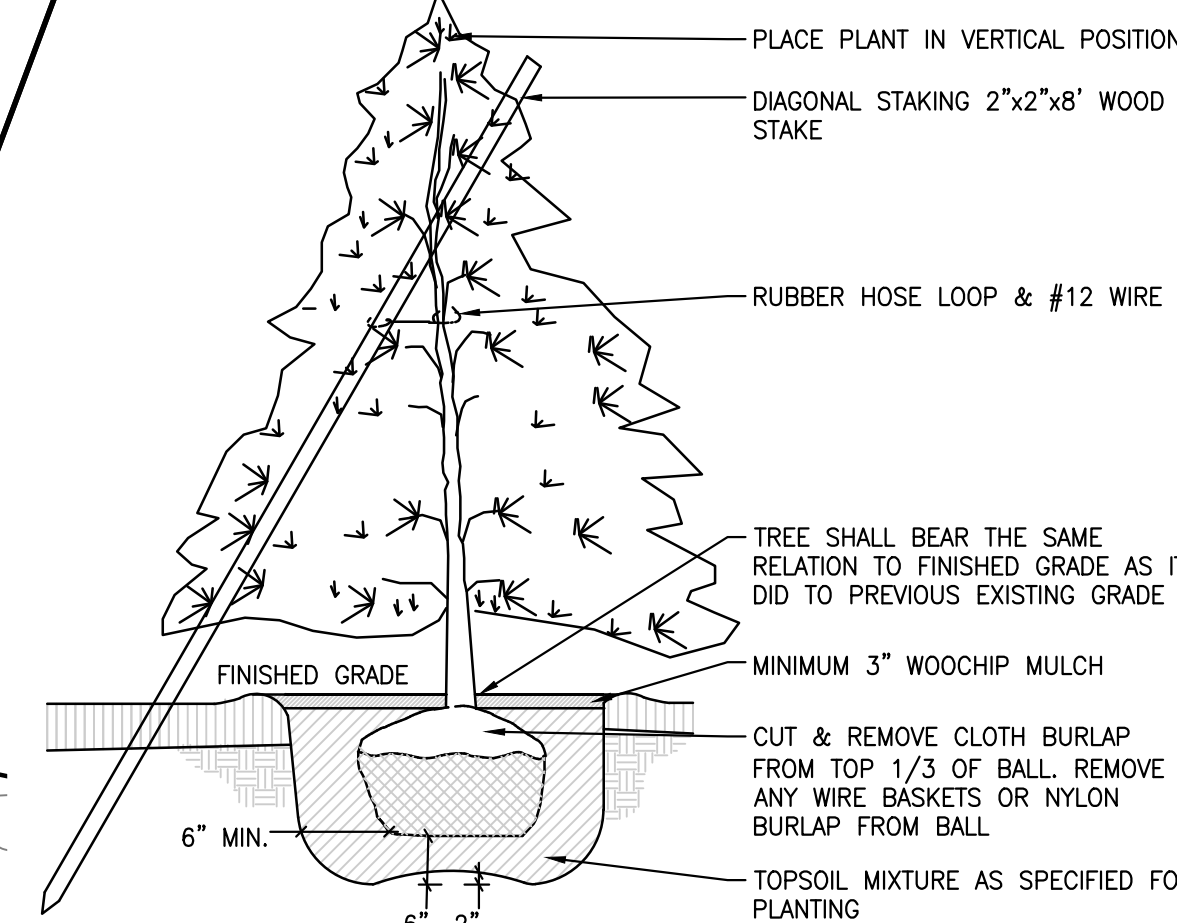
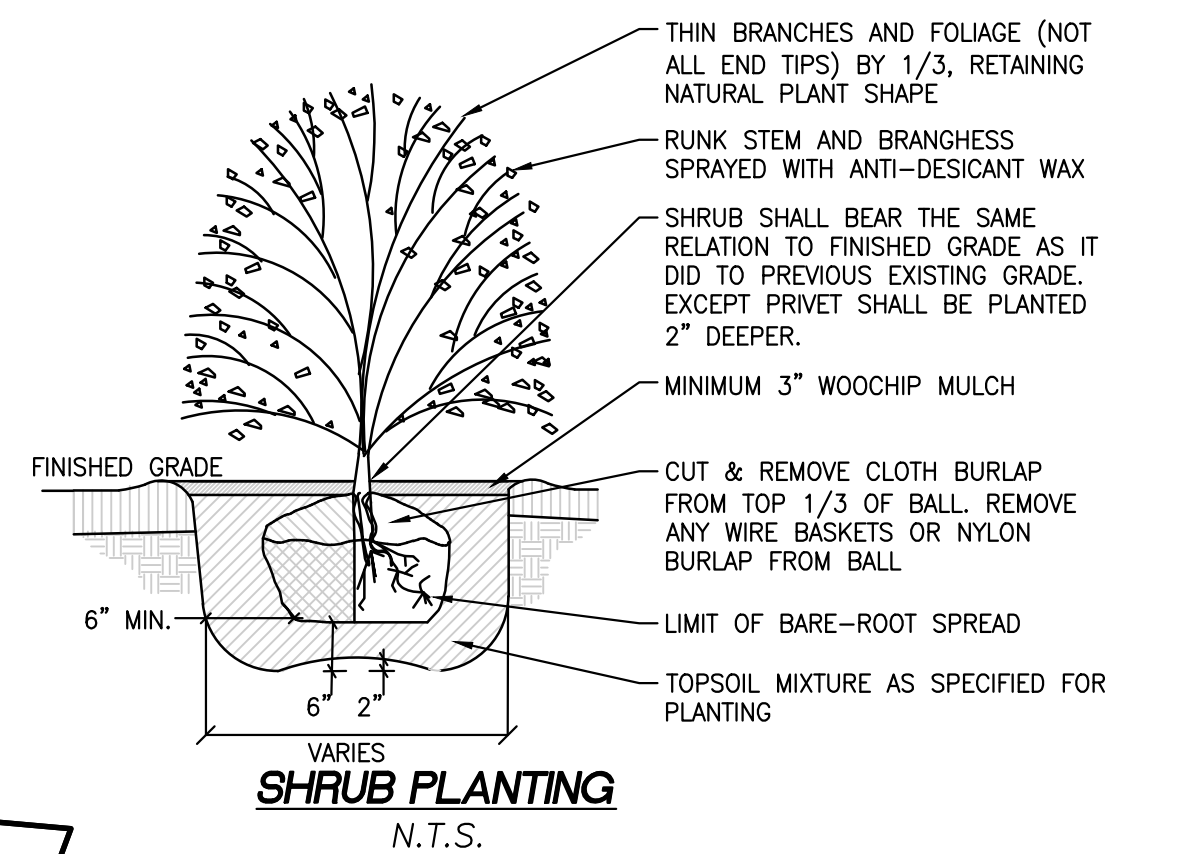

- GENERAL NOTES**
- ALL PLANT STOCK SHALL CONFORM TO ANSI Z260.1 - NURSERY STOCK, LATEST EDITION (AMERICAN ASSOCIATION OF NURSERYMEN, INC.).
  - NO TREES OR SHRUBS SHALL BE PLANTED AT THE STREET INTERSECTION WHERE THEY COULD BECOME A TRAFFIC HAZARD BY OBSTRUCTING VISION.
  - ALL TREES SHALL BE GUARANTEED BY THE DEVELOPER FOR THEIR ERRECTNESS AND GOOD HEALTH FOR TWO (2) YEARS AFTER PLANTING.
  - ALL AREAS DISTURBED DURING CONSTRUCTION SHALL BE LOAMED AND SEEDED. LOAM DEPTH SHALL BE A MINIMUM OF 4 INCHES. ALL LOAM PLACED SHALL BE pH CORRECTED AND FREE OF CLODS, LUMPS, STONES AND OTHER DELETERIOUS MATERIAL.
  - ANY DEAD VEGETATION SHALL BE REMOVED IMMEDIATELY AND REPLACED IN ACCORDANCE WITH THE SPECIFICATION ON PLAN.
  - OWNER SHALL MAINTAIN LANDSCAPE PLANTINGS TO ENSURE THE AESTHETIC APPEARANCE AND OVERALL PLANT HEALTHINESS IS RETAINED. THIS INCLUDES INSPECTING AND REPLACING PLANTINGS AS NECESSARY, WEEKLY MOWING AND MULCHING.
  - AN APPROVED SET OF PLANS AND ALL APPLICABLE PERMITS MUST BE AVAILABLE AT THE CONSTRUCTION SITE.
  - ANY DAMAGE TO PUBLIC OR PRIVATE PROPERTY RESULTING FROM CONSTRUCTION ACTIVITIES SHALL BE REPAIRED BY THE CONTRACTOR AT THEIR EXPENSE.
  - THE CONSTRUCTION SITE SHALL BE SECURED IN A MANNER SO AS TO PREVENT INJURY OR PROPERTY DAMAGE TO THE RESIDENTS OF THE TOWN.
  - AN APPROVED SITE AS-BUILT SHALL BE SUBMITTED TO THE ENGINEERING DIVISION WITHIN 60 DAYS OF CERTIFICATE OF OCCUPANCY. THE AS-BUILT SHALL BE SUBMITTED IN MYLAR AND ELECTRONIC ACAD FORMAT.

- ENDORSEMENT NOTES**
- TREE SPECIES SPECIFIED HEREIN ARE SIMPLY RECOMMENDED SPECIES BY THE ENGINEER OF RECORD, HOWEVER, THE CONTRACTOR SHALL COORDINATE WITH THE TREE WARDEN TO DETERMINE THE ACTUAL TREE SPECIES TO BE PLANTED.
  - RESTITUTION TO BE PAID IN FULL PRIOR TO THE REMOVAL OF TOWN-OWNED TREES AS OUTLINED IN THE "PUBLIC SHADE TREE REMOVAL APPLICATION" WITH A DATE OF ACTION OF 5/27/2021 AND SIGNED BY THE TREE WARDEN.

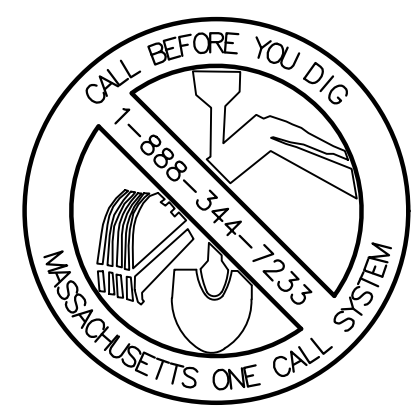

**REVISION**

REVISION	DATE	BY

**PROJECT LOCATION:**  
LOTS 2, 3, & 4  
GRANDVIEW ROAD  
READING, MA 01867  
**PARCEL ID:**  
MAP 27, LOT 404

**PLAN SET:**  
MAJOR SITE PLAN MODIFICATION  
GRANDVIEW ROAD SUBDIVISION - PRIVATE WAY  
(GRANDVIEW ROAD EXTENSION)  
**SITE PLAN PERMIT SET**

APRIL 20, 2023  
SCALE: 1" = 20'

**TOWN OF READING**  
COMMUNITY PLANNING & DEVELOPMENT COMMISSION  
DATE: \_\_\_\_\_  
\_\_\_\_\_  
\_\_\_\_\_  
\_\_\_\_\_

FOR REGISTRY USE ONLY

**ENGINEER:** FODERA ENGINEERING  
617-877-3293  
gfodera@foderaengineering.com  
28 Harbor St., Suite 204  
Danvers, MA 01923

**SURVEYOR:** PFS Land Surveying, Inc.  
20 Bulch Avenue  
Groveland, MA 01834  
P.978.891.5203  
www.pfsland.com

**PROFESSIONAL SEAL**  
GIOVANNI GAETANO FODERA  
No. 54884  
REGISTERED PROFESSIONAL ENGINEER

**COPYRIGHT NOTICE**  
This drawing is property of Fodera Engineering and is not to be used for any purpose other than the specific project and site named herein, and cannot be reproduced in any manner without the express written permission from the engineer on record.

**JOB NO.:** 20160-149  
**SHEET TITLE:** SITE AND TREE PRESERVATION  
**SHEET NUMBER:** C-2

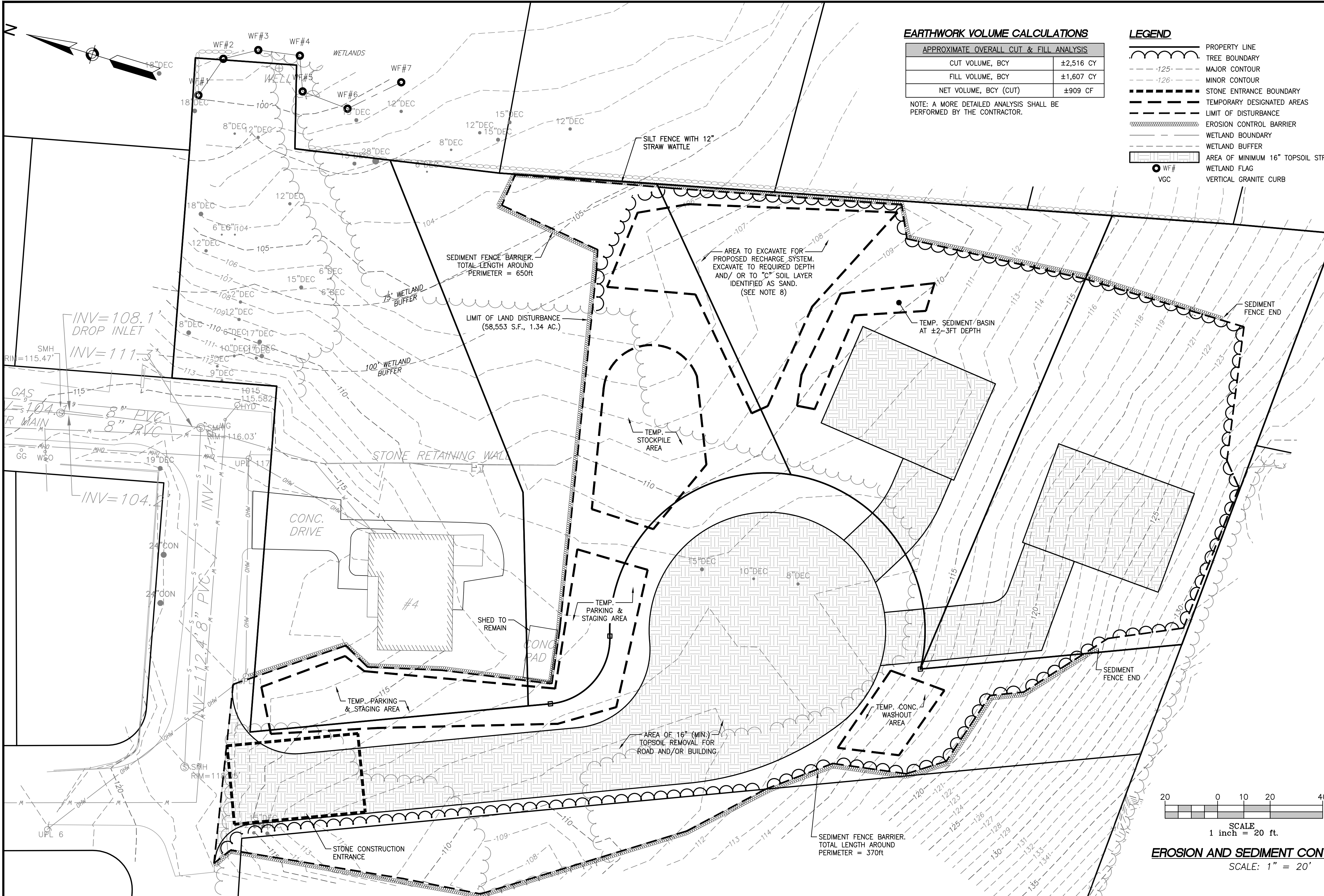

**EARTHWORK VOLUME CALCULATIONS**

APPROXIMATE OVERALL CUT & FILL ANALYSIS	
CUT VOLUME, BCY	±2,516 CY
FILL VOLUME, BCY	±1,607 CY
NET VOLUME, BCY (CUT)	±909 CF

NOTE: A MORE DETAILED ANALYSIS SHALL BE PERFORMED BY THE CONTRACTOR.

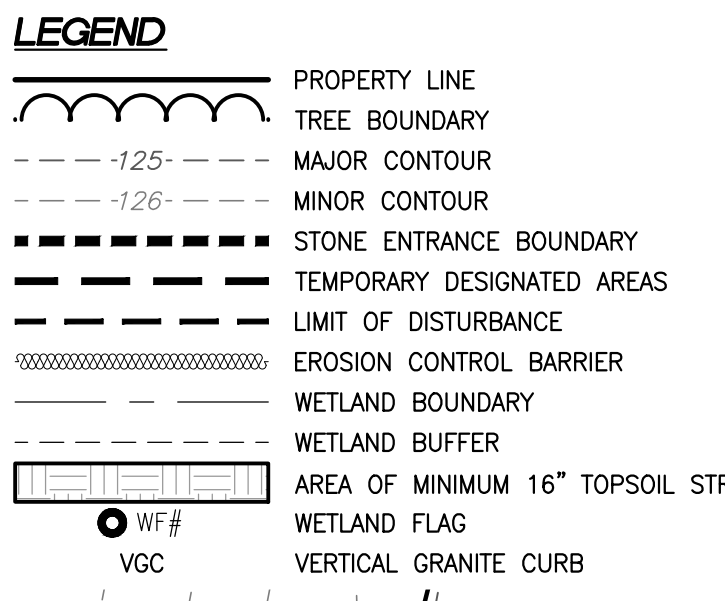

- EROSION CONTROL NOTES**
- PRIOR TO COMMENCING LAND DISTURBANCE ACTIVITY THE LIMITS OF LAND DISTURBANCE SHALL BE CLEARLY AND ACCURATELY DEMARCATED WITH STAKES, RIBBONS, OR OTHER APPROPRIATE MEANS.
  - INSTALL SEDIMENTATION AND EROSION CONTROL MEASURES PRIOR TO CLEARING GRADING AND DEMOLITION WORK. MAINTAIN ALL SEDIMENT AND EROSION CONTROL, AND TREE PROTECTION MEASURES UNTIL PERMANENT GROUND COVER IS ESTABLISHED.
  - ALL EROSION AND SEDIMENT CONTROL PRACTICES ARE SUBJECT TO FIELD MODIFICATIONS AT THE DIRECTION OF THE TOWN'S DPW ENGINEERING DEPARTMENT.
  - PRIOR TO ANY OTHER CONSTRUCTION, A STABILIZED CONSTRUCTION ENTRANCE SHALL BE CONSTRUCTED AT EACH ENTRY TO OR EXIT FROM THE SITE. CONSTRUCTION SHALL MAINTAIN CONSTRUCTION ENTRANCE UNTIL SITE PAVING IS COMPLETE.
  - INLET PROTECTIONS SHALL BE INSTALLED ON ALL EXISTING CATCH BASINS AS INDICATED ON THE PLAN, AND IMMEDIATELY AFTER THE INSTALLATION OF ALL NEWLY INSTALLED INLETS.
  - THE CONSTRUCTION ENTRANCE SHALL BE MAINTAINED IN A CONDITION WHICH WILL PREVENT TRACKING OR FLOW OF MUD ONTO THE ACCESSING ROADWAY. THIS MAY REQUIRE PERIODIC TOP DRESSING WITH STONE, AS CONDITIONS DEMAND, AND REPAIR AND/OR CLEAN-OUT OF ANY STRUCTURES USED TO TRAP SEDIMENT. ALL MATERIALS SPILLED, DROPPED, WASHED, OR TRACKED BY VEHICLE OFF-SITE ONTO THE ROADWAY OR INTO STORM DRAINS MUST BE REMOVED.
  - IMMEDIATELY AFTER THE ESTABLISHMENT OF CONSTRUCTION ENTRANCES/EXITS, ALL PERIMETER EROSION CONTROL DEVICES AND STORM WATER MANAGEMENT DEVICES SHALL BE INSTALLED PRIOR TO ANY OTHER CONSTRUCTION.
  - ADD EROSION BARRIER AROUND PERIMETER OF PROPOSED RECHARGE AREA IF THE EXCAVATED PIT WILL REMAIN EXPOSED FOR MORE THAN TWO (2) DAYS, WEATHER PERMITTING. THE EXCAVATED PIT SHALL BE CLEAN OF ALL SEDIMENT.
  - EROSION CONTROL DEVICES SHALL BE INSTALLED BEFORE GROUND DISTURBANCE OCCURS. THE LOCATION OF SOME OF THE EROSION CONTROL DEVICES MAY HAVE TO BE ALTERED FROM THAT SHOWN ON THE APPROVED PLANS IF DRAINAGE PATTERNS DURING CONSTRUCTION ARE DIFFERENT FROM THE FINAL PROPOSED DRAINAGE PATTERNS. IT IS THE CONTRACTOR'S RESPONSIBILITY TO ACCOMPLISH EROSION CONTROL FOR ALL DRAINAGE PATTERNS CREATED AT VARIOUS STAGES DURING CONSTRUCTION. ANY DIFFICULTY IN CONTROLLING EROSION DURING ANY PHASE OF CONSTRUCTION SHALL BE REPORTED TO THE ENGINEER IMMEDIATELY.
  - THE CONSTRUCTION OF THE SITE WILL INITIATE WITH THE INSTALLATION OF EROSION CONTROL MEASURES SUFFICIENT TO CONTROL SEDIMENT DEPOSITS AND EROSION. ALL SEDIMENT CONTROL WILL BE MAINTAINED UNTIL ALL UPSTREAM GROUND WITHIN THE CONSTRUCTION AREA HAS BEEN COMPLETELY STABILIZED WITH PERMANENT VEGETATION AND ALL ROADS/DRIVES HAVE BEEN PAVED.
  - THE CONTRACTOR SHALL FURNISH AND MAINTAIN ALL NECESSARY BARRICADES WHILE IMPROVEMENTS ARE BEING MADE. TRAFFIC CONTROL MEASURES TO BE IN ACCORDANCE WITH LOCAL REGULATIONS AND OR MASSDOT.
  - ALL SILT BARRIERS MUST BE PLACED AS ACCESS IS OBTAINED DURING CLEARING. NO GRADING SHALL BE DONE UNTIL SILT BARRIER INSTALLATION AND DETENTION FACILITIES, IF REQUIRED, ARE CONSTRUCTED.
  - CONTRACTOR SHALL PERFORM EROSION CONTROL INSPECTIONS REGULARLY AND IMMEDIATELY FOLLOWING HEAVY RAIN STORMS TO ENSURE MEASURES ARE FUNCTIONING PROPERLY. REPAIR OR REPLACE FAILED SYSTEMS AT THE EARLIEST POSSIBLE DATE.
  - ANY DISTURBED AREA LEFT EXPOSED FOR A PERIOD GREATER THAN 14 DAYS SHALL BE STABILIZED WITH TEMPORARY SEEDING.
  - ALL DISTURBED AREAS, WITH NO SPECIFIED GROUND COVER ARE TO BE RESTORED WITH MINIMUM FOUR (4) INCHES OF TOPSOIL AND SEEDING.
  - PROPERTY MARKERS AND STREET LINE MONUMENTS SHALL BE PROPERLY PROTECTED AT ALL TIMES DURING CONSTRUCTION TO ENSURE INTEGRITY. IF DISTURBED, THEY SHALL BE REPLACED BY A REGISTERED SURVEYOR AT THE CONTRACTOR'S EXPENSE.
  - ALL EXCAVATION SHALL INCLUDE CLEARING, STRIPPING AND STOCKPILING TOPSOIL, REMOVING UNSUITABLE MATERIALS, THE CONSTRUCTION OF EMBANKMENTS, CONSTRUCTION FILLS, AND THE FINAL SHAPING AND TRIMMING TO THE LINES AND GRADES SHOWN ON THE PLANS.
  - ALL TREES, BRUSH, AND ORGANIC TOPSOIL AND OTHER OBJECTIONABLE MATERIAL SHALL BE REMOVED, UNLESS OTHERWISE SPECIFIED, AND DISPOSED OF AT AN OFF-SITE LOCATION, WITH THE EXCEPTION THAT ENOUGH TOPSOIL SHALL BE RETAINED FOR RE-SPREAD AND GENERAL LANDSCAPING. AREAS WHICH ARE TO BE FILLED SHALL BE COMPACTED TO A MINIMUM DENSITY OF 95% AS DETERMINED BY THE MODIFIED PROCTOR (ASTM D1557, METHOD C) COMPACTION TEST IN THE PAVED AREAS AND 90% IN THE OTHER AREAS.
  - SWEEP CLEAN THE BINDER COURSE PRIOR TO THE INSTALLATION OF THE FINAL BITUMINOUS CONCRETE SURFACE COURSE. EXCESSIVE CLEANING OF THE BINDER COURSE THAT MAY BE REQUIRED, AND IS NOT THE FAULT OF THE PAVING CONTRACTOR, SHALL BE PAID FOR ON A TIME AND MATERIAL BASIS BY PRIOR AGREEMENT WITH THE GENERAL CONTRACTOR.
  - THE TOWN'S ENGINEERING DIVISION SHALL BE NOTIFIED SEVENTY-TWO (72) HOURS PRIOR TO ANY EXCAVATION TO MARK OUT TOWN UTILITIES.
  - ALL WATER, SEWER, CURB CUT, STREET OPENING AND JACKIE'S LAW EXCAVATION PERMITS SHALL BE OBTAINED AT THE ENGINEERING DIVISION PRIOR TO ANY EXCAVATIONS.
  - ALL SITE WORK SHALL BE INSPECTED BY THE ENGINEERING DIVISION. THE APPLICANT/OWNER'S CONTRACTOR SHALL SUBMIT A CONSTRUCTION SCHEDULE OF PROPOSED WORK. ALL INSPECTIONS SHALL BE SCHEDULED 48 HOURS IN ADVANCE.

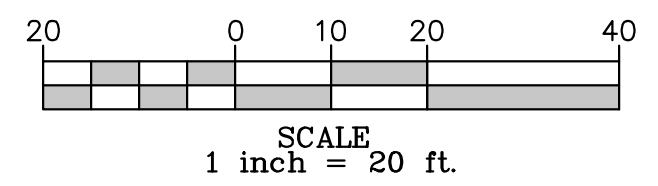

**EROSION AND SEDIMENT CONTROL PLAN**  
SCALE: 1" = 20'

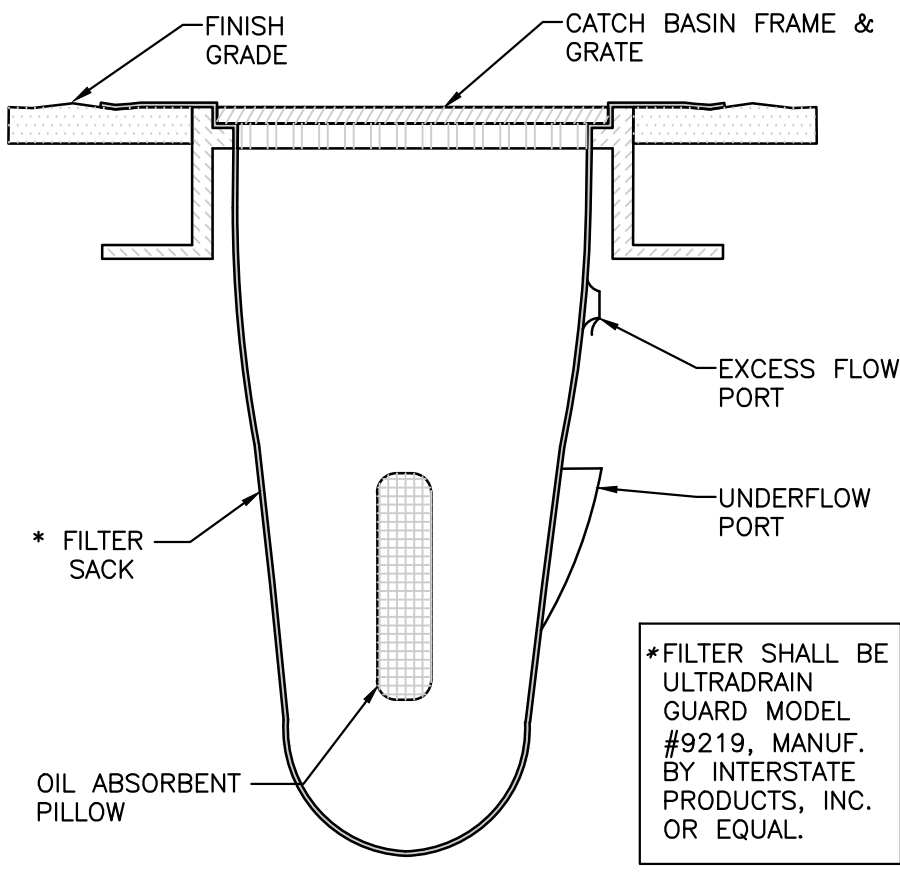

**CATCH BASIN INLET PROTECTION**  
N.T.S.

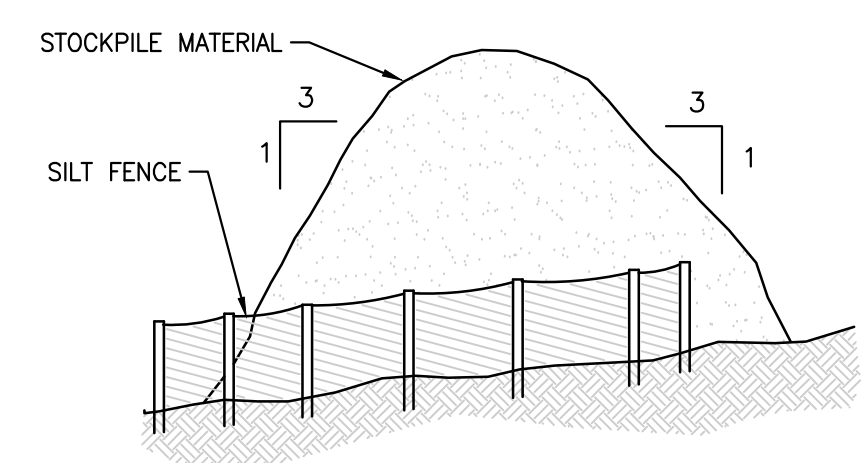

- NOTES:**
- STOCKPILE HEIGHTS MUST NOT EXCEED 35 FEET.
  - STOCKPILE SLOPES MUST BE 3:1 OR FLATTER.

**STOCKPILE DETAIL**  
N.T.S.

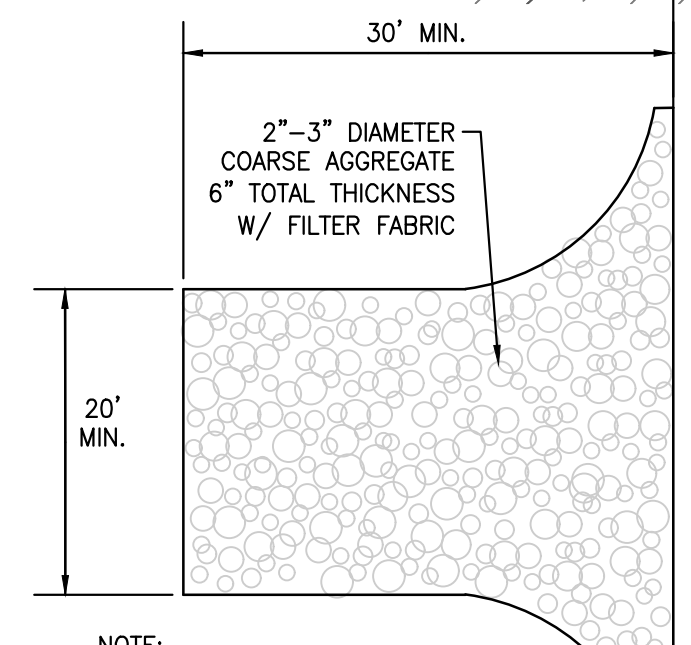

- NOTE:**
- GRAVEL PAD IS REQUIRED TO PROVIDE BUFFER AREA WHERE VEHICLES CAN DROP MUD AND SEDIMENT TO AVOID TRANSPORTING IT ONTO PAVED ROADS, TO CONTROL EROSION FROM SURFACE RUNOFF AND TO HELP CONTROL DUST.

**STONE CONSTRUCTION ENTRANCE**  
N.T.S.

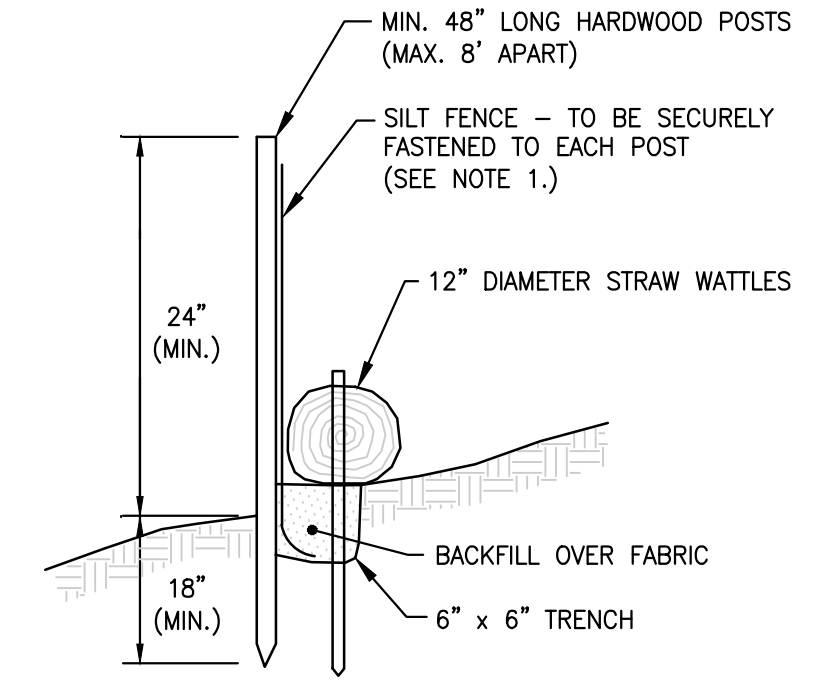

- NOTES:**
- WATTLES SHALL BE STAKED A MINIMUM OF 24 INCHES INTO THE GROUND WITH 2 INCHES OR LESS OF STAKE EXPOSED ABOVE WATTLE. STAKE SHALL BE A MAXIMUM OF 4 FEET APART AND WITHIN 2 FEET OF END OF WATTLE SECTIONS.

**SILT FENCE/ STRAW WATTLE BARRIER**  
N.T.S.

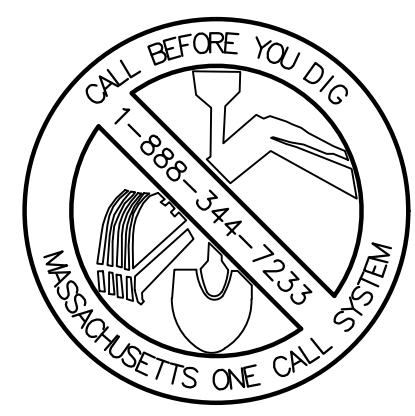

REVISION	DATE	BY

**PROJECT LOCATION:**  
LOTS 2, 3, & 4  
GRANDVIEW ROAD  
READING, MA 01867

**PARCEL ID:**  
MAP 27, LOT 404

**PLAN SET:**  
MAJOR SITE PLAN MODIFICATION  
GRANDVIEW ROAD SUBDIVISION - PRIVATE WAY  
(GRANDVIEW ROAD EXTENSION)

**DATE:** APRIL 20, 2023

**SCALE:** 1" = 20'

**SITE PLAN PERMIT SET**

TOWN OF READING  
COMMUNITY PLANNING & DEVELOPMENT COMMISSION

DATE: \_\_\_\_\_

FOR REGISTRY USE ONLY

**ENGINEER:**  
**FODERA ENGINEERING**  
(617)877-3293  
gfodera@foderaengineering.com  
28 Harbor St., Suite 204  
Danvers, MA 01923

**SURVEYOR:**  
**PFS Land Surveying, Inc.**  
30 Balch Avenue  
Groveland, MA 01834  
P.978.891.5203  
www.pfsland.com



**COPYRIGHT NOTICE:**  
This drawing is property of Fodera Engineering and is not to be used for any purpose other than the specific project and site named herein, and cannot be reproduced in any manner without the express written permission from the engineer on record.

**JOB NO.:** 20160-149

**SHEET TITLE:**  
EROSION + SEDIMENT CONTROL PLAN

**SHEET NUMBER:**  
C-3

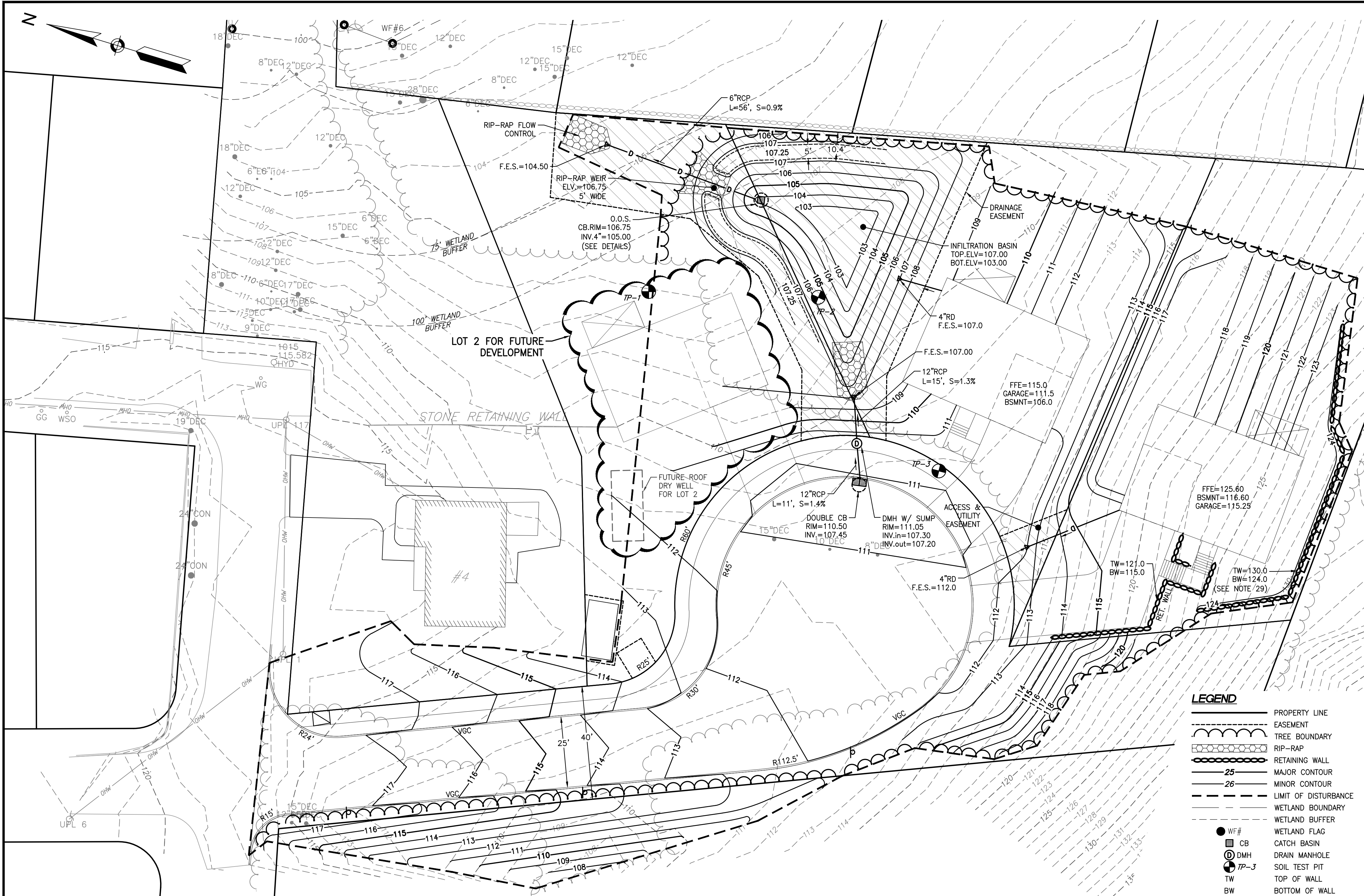

- GRADING AND DRAINAGE NOTES**
- ALL CONSTRUCTION MATERIALS AND WORKMANSHIP SHALL BE IN ACCORDANCE TO THE TOWN'S LATEST CONSTRUCTION SPECIFICATIONS AND DETAILS.
  - GRADING IN THE RIGHT-OF-WAY SHALL IN ACCORDANCE WITH LOCAL REGULATIONS, UNLESS OTHERWISE APPROVED BY THE TOWN.
  - THE CONTRACTOR SHALL NOTIFY DIG SAFE AND THE TOWN A MINIMUM OF 72 HOURS PRIOR TO THE START OF ANY EXCAVATIONS.
  - INSTALL ALL APPROPRIATE TREE PROTECTION MEASURES PRIOR TO GRADING AND EXCAVATION.
  - EXACT LOCATIONS OF SAW-CUTTING MAY BE FIELD DETERMINED BASED ON EXISTING PAVEMENT CONDITIONS.
  - THE CONTRACTOR SHALL CAREFULLY PRESERVE BENCHMARKS, REFERENCE POINTS AND STAKES.
  - EROSION CONTROL MEASURES SHALL BE STABILIZED IN PLACE BEFORE BEGINNING SITE WORK. THESE MEASURES SHALL BE MAINTAINED THROUGHOUT CONSTRUCTION.
  - ALL INDICATED ELEVATIONS ARE FINISHED ELEVATIONS.
  - LOCATE AND PROTECT ALL UTILITIES ASSOCIATED WITH THE PROJECT PRIOR TO CONSTRUCTION.
  - ALL EXCAVATION SHALL INCLUDE CLEARING, STRIPPING AND STOCKPILING TOPSOIL, REMOVING UNSUITABLE MATERIALS, THE CONSTRUCTION OF EMBANKMENTS, CONSTRUCTION FILLS, AND THE FINAL SHAPING AND TRIMMING TO THE LINES AND GRADES SHOWN ON THE PLANS.
  - ALL TREES, BRUSH, AND ORGANIC TOPSOIL AND OTHER OBJECTIONABLE MATERIAL SHALL BE REMOVED, UNLESS OTHERWISE SPECIFIED, AND DISPOSED OF AT AN OFF-SITE LOCATION, WITH THE EXCEPTION THAT ENOUGH TOPSOIL SHALL BE RETAINED FOR RE-SPREAD AND GENERAL LANDSCAPING AREAS WHICH ARE TO BE FILLED SHALL BE COMPACTED TO A MINIMUM DENSITY OF 95% AS DETERMINED BY THE MODIFIED PROCTOR (ASTM D1557, METHOD C) COMPACTION TEST IN THE PAVED AREAS AND 90% IN THE OTHER AREAS.
  - CONTRACTOR SHALL PROVIDE POSITIVE DRAINAGE TO ALL INLETS AND CATCH BASINS. AREAS OF SURFACE PONDING SHALL BE CORRECTED BY CONTRACTOR AT NO ADDITIONAL EXPENSE TO THE OWNER.
  - IF AREAS ARE DISTURBED BEYOND PROPOSED GRADES BY NEGLIGENCE OF THE CONTRACTOR, THE CONTRACTOR SHALL BE HELD RESPONSIBLE FOR ANY REGRADING OR REPAIR TO MATCH ORIGINAL EXISTING CONDITIONS.
  - SHORING SHALL BE DONE AS NECESSARY FOR THE PROTECTION OF THE WORK AND FOR THE SAFETY OF PERSONNEL. SHORING SHALL BE IN ACCORDANCE WITH ALL O.S.H.A AND LOCAL REGULATIONS.
  - CONTRACTOR SHALL ADJUST GRADES BY VARYING THE PAVEMENT SECTIONS ACCORDINGLY. EXISTING COMPACTED SUBGRADE TO BE DISTURBED AS LITTLE AS POSSIBLE.
  - ALL PROPOSED SPOT ELEVATIONS SHOWN INDICATE FINISHED GRADED ELEVATIONS AT EDGE OF PAVEMENT AND/OR GRADE BREAKS, UNLESS OTHERWISE NOTED.
  - MAINTAIN PROPER SITE DRAINAGE AT ALL TIMES DURING THE COURSE OF CONSTRUCTION, AND PREVENT STORM WATER FROM RUNNING INTO OR STANDING IN EXCAVATED AREAS.
  - SPREAD AND COMPACT UNIFORMLY TO THE DEGREE SPECIFIED ALL EXCESS TRENCH SPOIL AFTER COMPLETION OF THE UNDERGROUND IMPROVEMENTS (EARTHWORK CONTRACTOR SHALL MAKE APPROPRIATE ADJUSTMENTS IN ROUGH GRADING TO ACCOMMODATE TRENCH SPOIL).
  - PROVIDE WATER TO ADD TO DRY MATERIAL IN ORDER TO ADJUST THE MOISTURE CONTENT FOR THE PURPOSE OF ACHIEVING THE SPECIFIED COMPACTION.
  - UNSUITABLE MATERIAL SHALL BE CONSIDERED AS MATERIAL WHICH IS NOT SUITABLE FOR THE SUPPORT OF PAVEMENT AND BUILDING CONSTRUCTION, AND IS ENCOUNTERED BELOW NORMAL TOPSOIL DEPTHS AND THE PROPOSED SUB-GRADE ELEVATION. THE DECISION TO REMOVE SAID MATERIAL, AND TO WHAT EXTENT, SHALL BE MADE BY A SOILS ENGINEER WITH THE CONCURRENCE OF THE OWNER.
  - REPAIR ANY BASE COURSE AND BINDER COURSE FAILURES PRIOR TO THE INSTALLATION OF THE FINAL BITUMINOUS CONCRETE SURFACE COURSE.
  - SWEEP CLEAN THE BINDER COURSE PRIOR TO THE INSTALLATION OF THE FINAL BITUMINOUS CONCRETE SURFACE COURSE. EXCESSIVE CLEANING OF THE BINDER COURSE THAT MAY BE REQUIRED, AND IS NOT THE FAULT OF THE PAVING CONTRACTOR, SHALL BE PAID FOR ON A TIME AND MATERIAL BASIS BY PRIOR AGREEMENT WITH THE GENERAL CONTRACTOR.
  - CONFIRM INVERTS OF ALL EXISTING STORM INLETS AND SANITARY SEWER MANHOLES BEFORE COMMENCING CONSTRUCTION.
  - A GEOTEXTILE MATTING (LANDLOCK TRM 450 OR EQUIVALENT) SHALL BE USED FOR EROSION CONTROL AN ALL SLOPES GREATER THAN 3H:1V IF NECESSARY.
  - DRAINAGE STRUCTURES AND UNDERGROUND INFILTRATION FACILITIES SHALL BE INSPECTED SEMIANNUALLY TO ENSURE PROPER WORKING ORDER.
  - UNSUITABLE EXISTING SOILS, SILT, AND DEBRIS SHALL BE ADEQUATELY REMOVED FROM THE AREA OF THE PROPOSED INFILTRATION BASIN. REMOVE ALL ORGANICS.
  - IF THE CONTRACTOR IN THE COURSE OF WORK FINDS ANY DISCREPANCIES BETWEEN THE PLANS AND THE PHYSICAL CONDITIONS OF THE LOCALITY, OR ANY ERRORS OR OMISSIONS IN THE PLANS OR IN THE LAYOUT AS GIVEN BY THE ENGINEER, IT SHALL BE HIS DUTY TO IMMEDIATELY INFORM THE ENGINEER, IN WRITING AND THE ENGINEER WILL PROMPTLY VERIFY THE SAME. ANY WORK DONE AFTER SUCH A DISCOVERY, UNTIL AUTHORIZED, WILL BE AT THE CONTRACTOR'S RISK.
  - ANNUAL O&M REPORTS SHALL BE DELIVERED TO THE OFFICE OF THE TOWN ENGINEER BY JANUARY 15 OF EACH YEAR.
  - ANY RETAINING WALL OVER FOUR (4) FEET IN RETAINED HEIGHT SHALL REQUIRE AN ENGINEERED DESIGN FROM A DESIGN PROFESSIONAL.

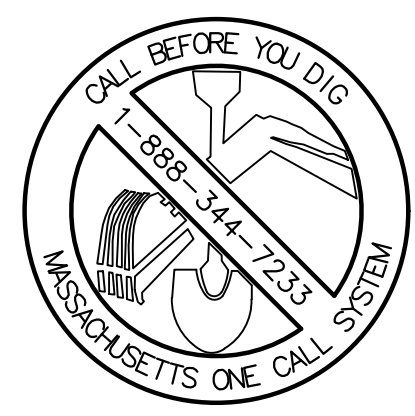

REVISION	DATE	BY

**PROJECT LOCATION:**  
 LOTS 2, 3 & 4  
 GRANDVIEW ROAD  
 READING, MA 01867  
**PARCEL ID:**  
 MAP 27, LOT 404

**PLAN SET:**  
 MAJOR SITE PLAN MODIFICATION  
 GRANDVIEW ROAD SUBDIVISION - PRIVATE WAY  
 (GRANDVIEW ROAD EXTENSION)  
 SCALE: 1" = 20'  
 APRIL 20, 2023  
 SITE PLAN PERMIT SET

**LEGEND**

—	PROPERTY LINE
---	EASEMENT
---	TREE BOUNDARY
--- ---	RIP-RAP
--- ---	RETAINING WALL
---	MAJOR CONTOUR
---	MINOR CONTOUR
---	LIMIT OF DISTURBANCE
---	WETLAND BOUNDARY
---	WETLAND BUFFER
● WF#	WETLAND FLAG
■ CB	CATCH BASIN
○ DMH	DRAIN MANHOLE
● TP-3	SOIL TEST PIT
---	TOP OF WALL
---	BOTTOM OF WALL
---	T.O.F.
---	F.F.E.
---	RIM
---	INVERT ELEVATION
○ O.O.S.	OVERFLOW OUTLET STRUCTURE
---	F.L.E.S.

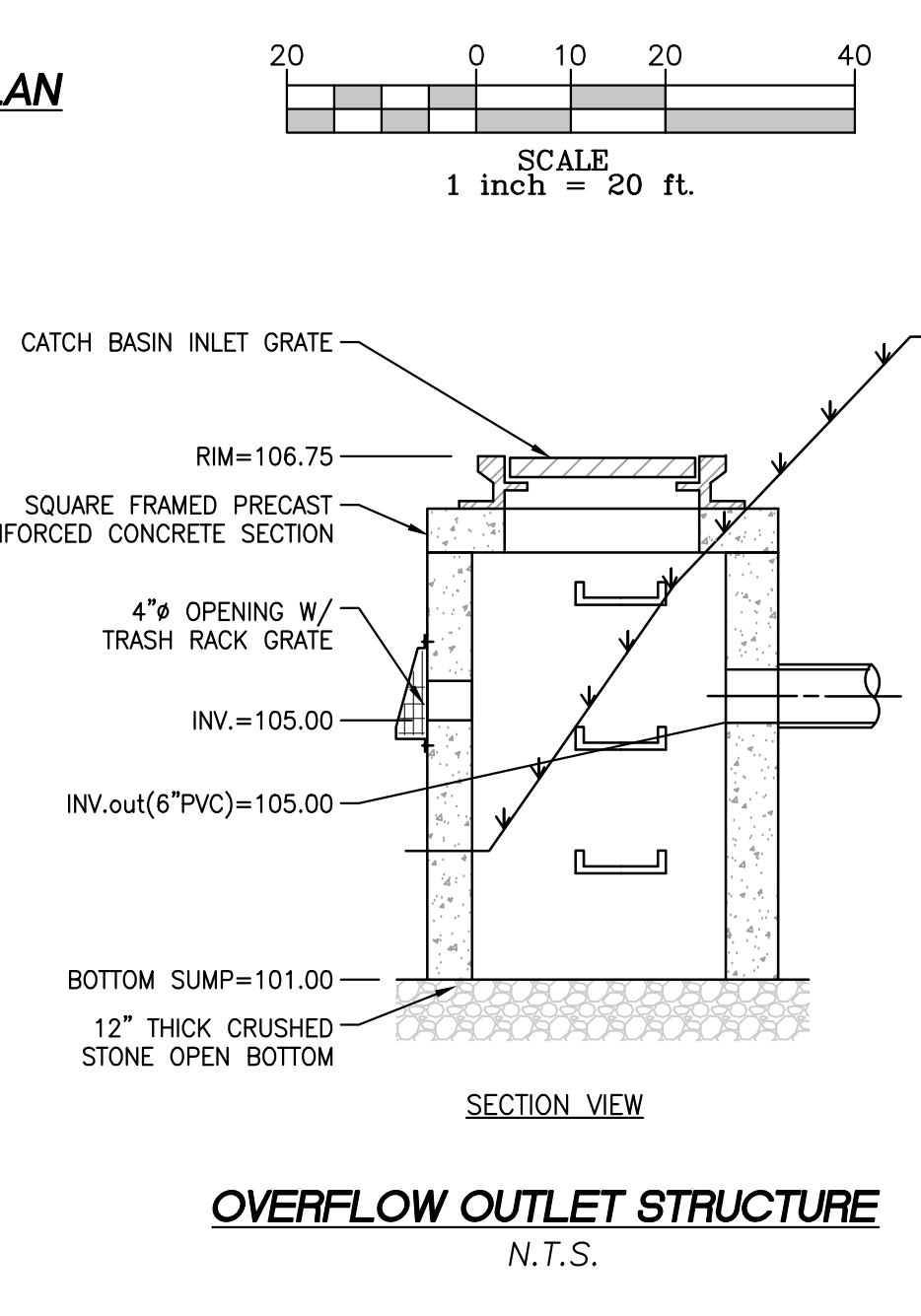
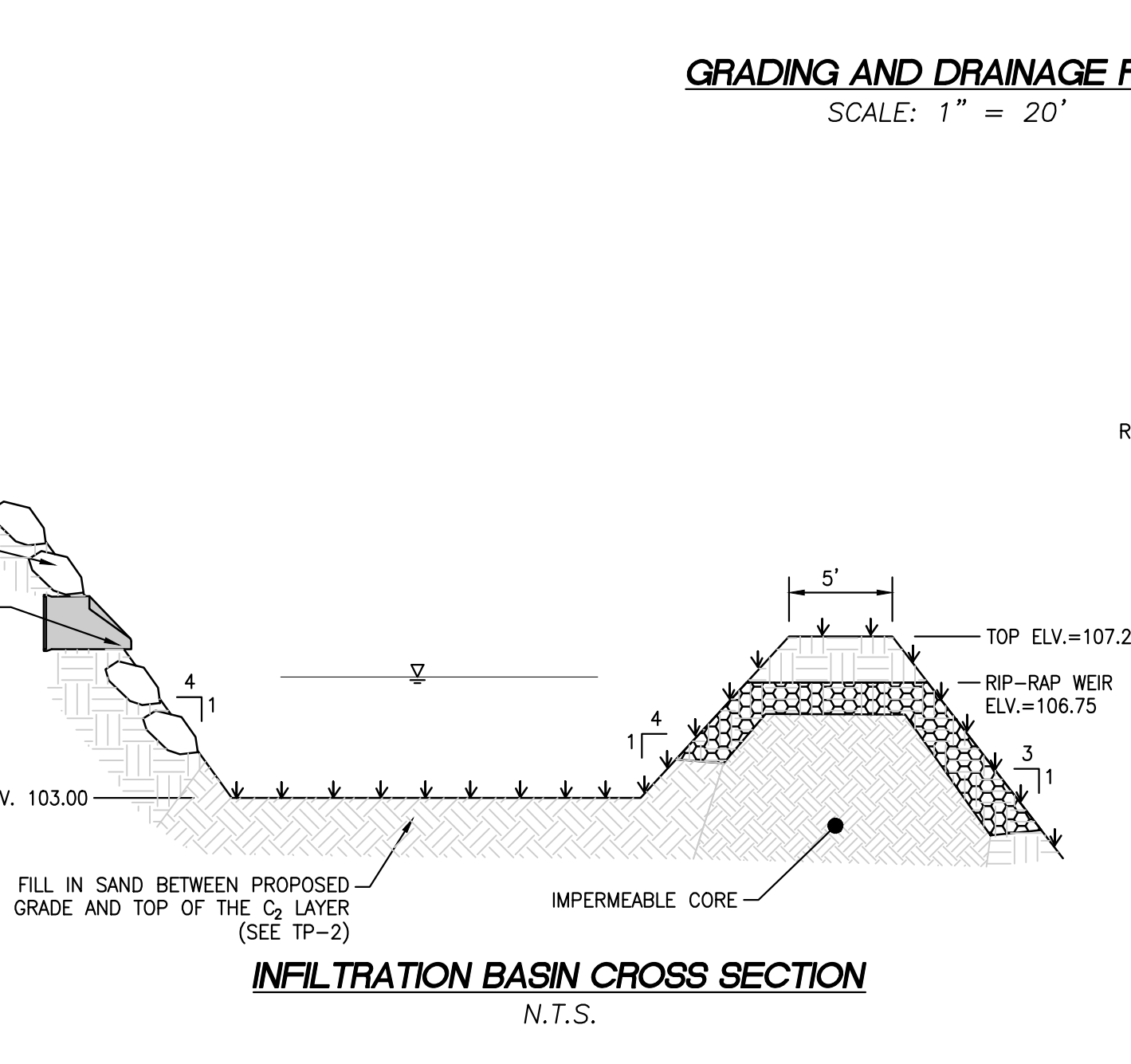
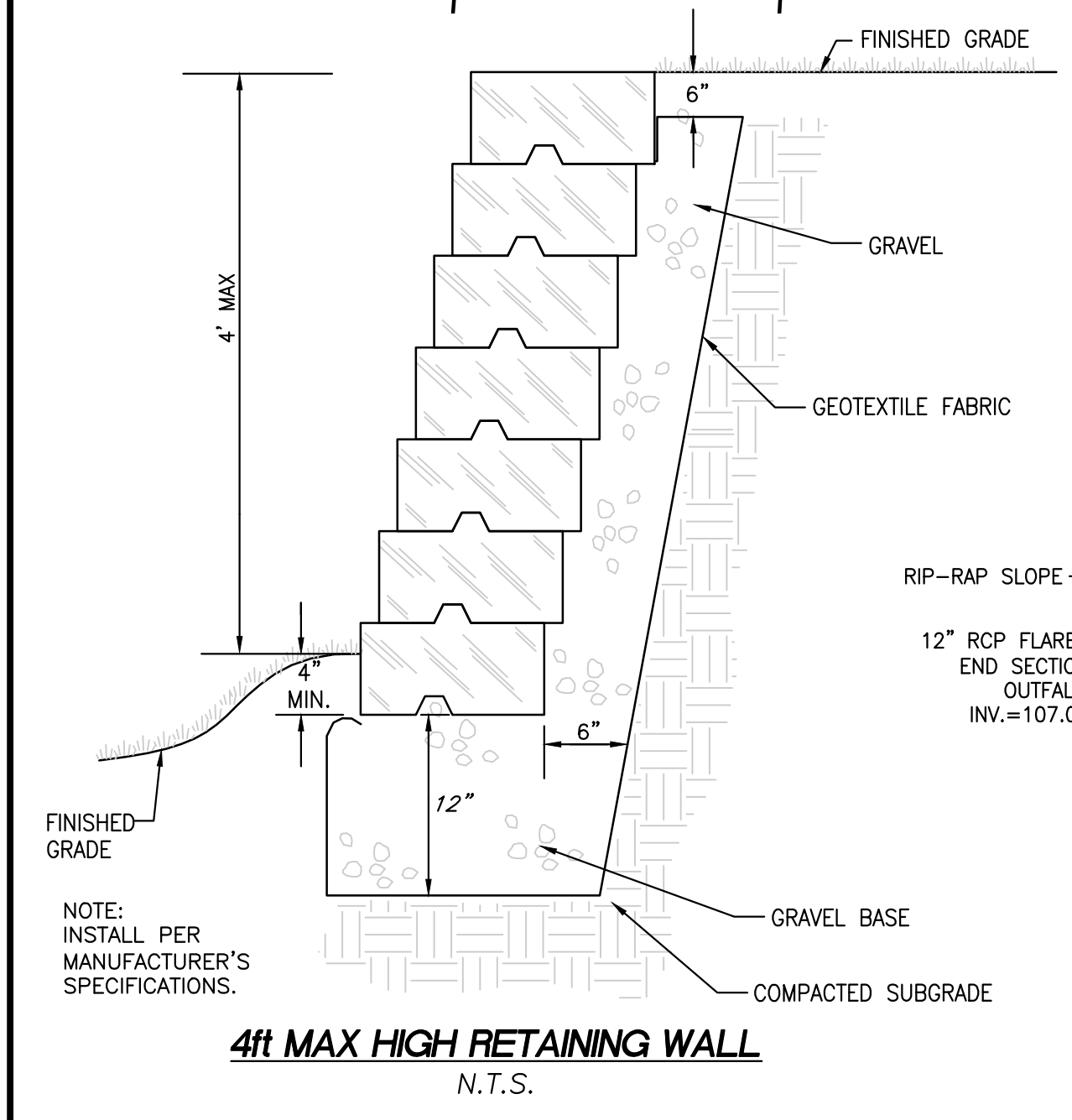

**SOIL TEST RESULTS**  
 TEST DATE: 7/6/2020  
 WEATHER: 65°F, SUNNY/ DRY  
 SOIL EVALUATOR: ARMAND PORRAZZO  
 LICENCE #: 1958

TP-1	TP-2	TP-3
ELV. DPT.	ELV. DPT.	ELV. DPT.
106 0"	108 0"	112 0"
105 9"	107 12"	111 8"
104 24"	106 36"	110 27"
103 10YR 3/2	105 36"	109 10YR 3/2
102 10YR 7/6	104 10YR 7/6	108 10YR 7/6
101 2.5Y 4/3	103 2.5Y 5/2	107 2.5Y 5/2
100 2.5Y 4/3	102 2.5Y 5/2	106 2.5Y 5/2
99	101	105
98	100	104
97 108"	99	103
96 120"	98	102
	97	101
	96	100
	95	99
	94	98
	93	97
	92	96
	91	95
	90	94
	89	93
	88	92
	87	91
	86	90
	85	89
	84	88
	83	87
	82	86
	81	85
	80	84
	79	83
	78	82
	77	81
	76	80
	75	79
	74	78
	73	77
	72	76
	71	75
	70	74
	69	73
	68	72
	67	71
	66	70
	65	69
	64	68
	63	67
	62	66
	61	65
	60	64
	59	63
	58	62
	57	61
	56	60
	55	59
	54	58
	53	57
	52	56
	51	55
	50	54
	49	53
	48	52
	47	51
	46	50
	45	49
	44	48
	43	47
	42	46
	41	45
	40	44
	39	43
	38	42
	37	41
	36	40
	35	39
	34	38
	33	37
	32	36
	31	35
	30	34
	29	33
	28	32
	27	31
	26	30
	25	29
	24	28
	23	27
	22	26
	21	25
	20	24
	19	23
	18	22
	17	21
	16	20
	15	19
	14	18
	13	17
	12	16
	11	15
	10	14
	9	13
	8	12
	7	11
	6	10
	5	9
	4	8
	3	7
	2	6
	1	5
	0	4

NO REFUSAL  
 NO WEEPING  
 REDOX @ 60"  
 ESHWT = 101.0

TOWN OF READING  
 COMMUNITY PLANNING & DEVELOPMENT COMMISSION  
 FOR REGISTRY USE ONLY  
 DATE: \_\_\_\_\_

**ENGINEER:**  
**FODERA ENGINEERING**  
 (617) 877-3293  
 gfodera@foderaengineering.com  
 28 Harbor St., Suite 204  
 Danvers, MA 01923  
 PROFESSIONAL SEAL

**SURVEYOR:**  
**PFS Land Surveying, Inc.**  
 20 Bulch Avenue  
 Groveland, MA 01834  
 P.978.891.5203  
 www.pfsland.com  
 PROFESSIONAL SEAL

**PROFESSIONAL SEAL**  
 GIOVANNI GAETANO FODERA  
 No. 54884  
 REGISTERED PROFESSIONAL ENGINEER

**PROFESSIONAL SEAL**  
 GIOVANNI GAETANO FODERA  
 No. 54884  
 REGISTERED PROFESSIONAL SURVEYOR

**COPYRIGHT NOTICE**  
 This drawing is property of Fodera Engineering and is not to be used for any purpose other than the specific project and site named herein, and cannot be reproduced in any manner without the express written permission from the engineer on record.

**JOB NO.:** 20160-149  
**SHEET TITLE:**  
 GRADING AND DRAINAGE PLAN  
**SHEET NUMBER:**  
 C-4

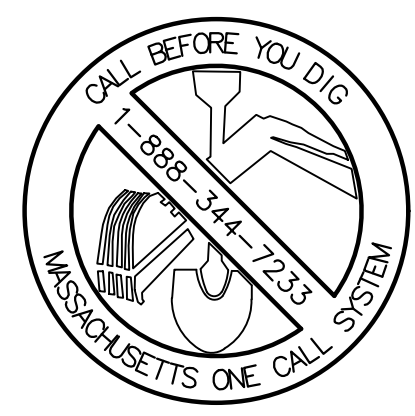

**SEWAGE CALCULATIONS**  
 ASSUMPTIONS MADE FOR EACH PROPOSED HOUSE TO CONTAIN FOUR (4) BEDROOMS. CALCULATIONS BELOW ARE IN ACCORDANCE TO 310 CMR 15.00.  
 3 NEW HOUSES \* 4 BEDROOMS PER HOUSE = 12 BEDROOMS ADDED  
 12 BEDROOMS \* 110 GAL/DAY = 1,320 GAL/DAY OF ADDED SEWAGE

- UTILITY NOTES**
- CONTRACTOR IS TO VERIFY THE LOCATION OF ALL EXISTING UTILITIES PRIOR TO CONSTRUCTION AND ENSURE NO CONFLICTS EXIST WITH PROPOSED IMPROVEMENTS. NOTIFY ENGINEER IMMEDIATELY IF UTILITIES ARE LOCATED DIFFERENTLY THAN SHOWN. THE CONTRACTOR SHALL COORDINATE WITH EACH RESPECTIVE UTILITY COMPANY IN ORDER TO RELOCATE IF NEEDED IN CONFORMANCE WITH THEIR GUIDELINES.
  - CONTRACTOR SHALL NOTIFY AND COORDINATE WITH THE APPROPRIATE UTILITY COMPANY PRIOR TO THE REMOVAL OF INDICATED UTILITIES ON SITE. CONTRACTOR SHALL BE RESPONSIBLE FOR OBTAINING ANY PERMITS REQUIRED FOR DEMOLITION AND HULL OFF FROM THE APPROPRIATE AUTHORITIES.
  - THE DEPARTMENT OF PUBLIC WORKS OR APPLICABLE GOVERNING DEPARTMENT MUST AUTHORIZE AND PERMIT TO CONSTRUCT, ALTER OR MODIFY A WATER OR SEWER LINE.
  - AT THE COMPLETION OF THE WATER AND/OR SEWER CONSTRUCTION AND PRIOR TO RECORDING THE FINAL PLAN, THE CONTRACTOR WILL FURNISH THE WATER SYSTEM INSPECTOR RECORD DRAWINGS OF THE PROJECT.
  - BUILDING CONTRACTOR SHALL BE RESPONSIBLE FOR COORDINATION WITH THE GAS COMPANY FOR THE CONSTRUCTION OF THE GAS LINE BETWEEN METER AND MAIN.
  - BUILDING CONTRACTOR SHALL BE RESPONSIBLE FOR COORDINATION WITH THE POWER COMPANY FOR THE CONSTRUCTION OF ELECTRICAL CONDUIT TO PROVIDE SERVICE AND IF A TRANSFORMER IS REQUIRED TO BE INSTALLED.
  - THE CONTRACTOR SHALL BE RESPONSIBLE FOR VERIFYING, PRIOR TO CONSTRUCTION, ALL EXISTING LOCATIONS AND INVERT ELEVATIONS OF SANITARY SEWERS, STORM DRAINAGE, AND WATER MAINS. IF ANY INVERT ELEVATION VARIES MORE THAN 0.1 FT. FROM RECORD ELEVATIONS, THE CONTRACTOR SHALL NOTIFY THE ENGINEER IMMEDIATELY. WORK SHALL NOT PROCEED UNTIL THE CONTRACTOR IS NOTIFIED BY THE ENGINEER.
  - CONNECT TO EXISTING UTILITIES AND INSTALL UTILITIES IN COMPLIANCE WITH REQUIREMENTS OF APPROPRIATE JURISDICTIONAL AGENCIES.
  - COORDINATE WITH BUILDING PLANS TO ASSURE ACCURACY OF UTILITY CONNECTIONS AND COMPLIANCE WITH LOCAL CODES.
  - ALL SEWERS TO BE MAINTAINED THROUGHOUT CONSTRUCTION, INCLUDING CLEANING OF ANY SILT OR DEBRIS ACCUMULATED IN STRUCTURES.
  - ALL SURPLUS EXCAVATED MATERIAL FROM THE TRENCH SHALL BE DISPOSED OFF THE SITE BY CONTRACTOR.
  - TRENCHING SHOULD BE CONDUCTED IN ACCORDANCE WITH ALL OSHA REGULATIONS.
  - COORDINATE EXACT TRENCHING, ROUTING, AND POINT OF TERMINATION WITH ALL UTILITY COMPANIES.
  - BACKFILL MATERIAL SHALL BE SUITABLE MATERIAL IN COMPLIANCE WITH THE TOWN OF DANVERS AND/OR THE MASSACHUSETTS DEPARTMENT OF TRANSPORTATION (MASSDOT).
  - WATER MAIN SHALL HAVE A MINIMUM COVER OF FIVE (5) FEET.
  - THE SANITARY SEWER AND POTABLE WATER LINES ARE TO BE SEPARATED BY AT LEAST 10 FEET HORIZONTALLY, OR THE POTABLE WATER LINE SHALL BE AT LEAST 18 INCHES VERTICALLY ABOVE THE SANITARY SEWER.
  - CONTRACTOR TO RECONFIGURE PROPOSED ELECTRIC/TELEPHONE/CABLE CONDUITS AS NECESSARY TO AVOID CONFLICT WITH TREES/LANDSCAPING.
  - THRUST BLOCKS TO BE PLACED AT ALL BEND LOCATIONS WITHIN THE POTABLE WATER LINES. SEE DETAIL SHEETS.
  - ALL UTILITIES SHALL BE APPROVED MATERIALS AND INSTALLED IN ACCORDANCE WITH THE DEPARTMENT OF PUBLIC WORKS STANDARDS.
  - THE TOWN'S ENGINEERING DIVISION SHALL BE NOTIFIED SEVENTY-TWO (72) HOURS PRIOR TO ANY EXCAVATION TO MARK OUT TOWN UTILITIES.

REVISION	DATE	BY

**PROJECT LOCATION:**  
 LOTS 2, 3, & 4  
 GRANDVIEW ROAD  
 READING, MA 01867  
**PARCEL ID:**  
 MAP 27, LOT 404

**PLAN SET:**  
 MAJOR SITE PLAN MODIFICATION  
 GRANDVIEW ROAD SUBDIVISION - PRIVATE WAY  
 (GRANDVIEW ROAD EXTENSION)  
 SITE PLAN PERMIT SET

**UTILITY AND ROADWAY PROFILE PLAN**  
 SCALE: 1" = 20' (HORIZONTAL)

**TOWN OF READING**  
 COMMUNITY PLANNING & DEVELOPMENT COMMISSION  
 DATE: \_\_\_\_\_  
 \_\_\_\_\_  
 \_\_\_\_\_  
 \_\_\_\_\_

FOR REGISTRY USE ONLY

**ENGINEER:**  
**FODERA ENGINEERING**  
 (617)877-3293  
 gfodera@foderaengineering.com  
 28 Harbor St., Suite 204  
 Danvers, MA 01923

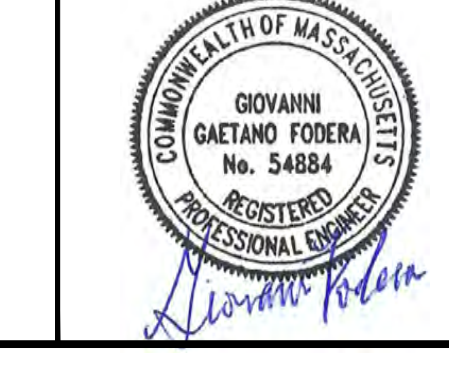

**SURVEYOR:**  
**PFS Land Surveying, Inc.**  
 20 Balch Avenue  
 Groveland, MA 01834  
 P.978.891.5203  
 www.pfsland.com

**COPYRIGHT NOTICE**  
 This drawing is property of Fodera Engineering and is not to be used for any purpose other than the specific project and site named herein, and cannot be reproduced in any manner without the express written permission from the engineer on record.

**JOB NO.:** 20160-149  
**SHEET TITLE:**  
 UTILITY + ROADWAY PROFILE PLAN  
**SHEET NUMBER:**  
 C-5

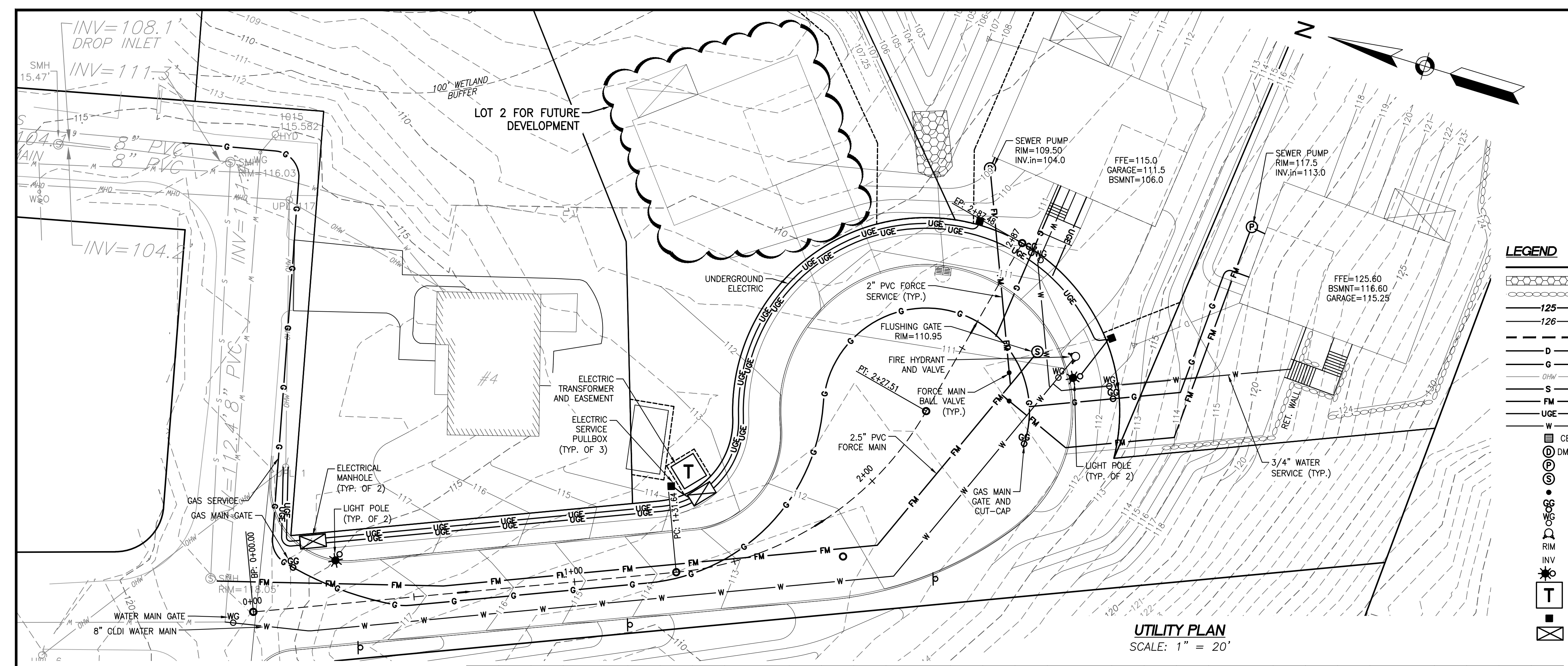

**UTILITY PLAN**  
 SCALE: 1" = 20'

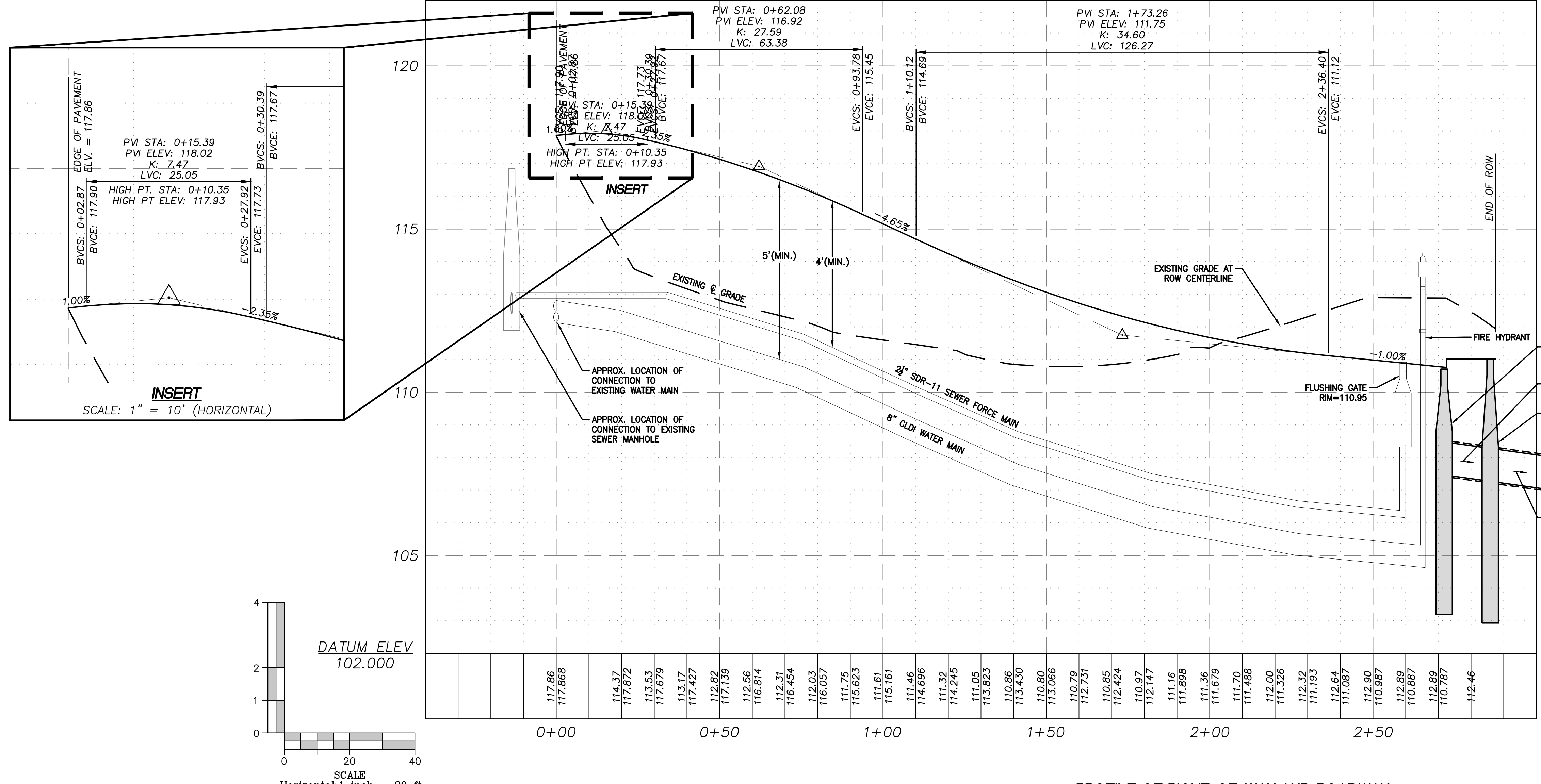

**PROFILE OF RIGHT-OF-WAY AND ROADWAY**  
 SCALE: 1" = 20' (HORIZONTAL)  
 1" = 2' (VERTICAL)

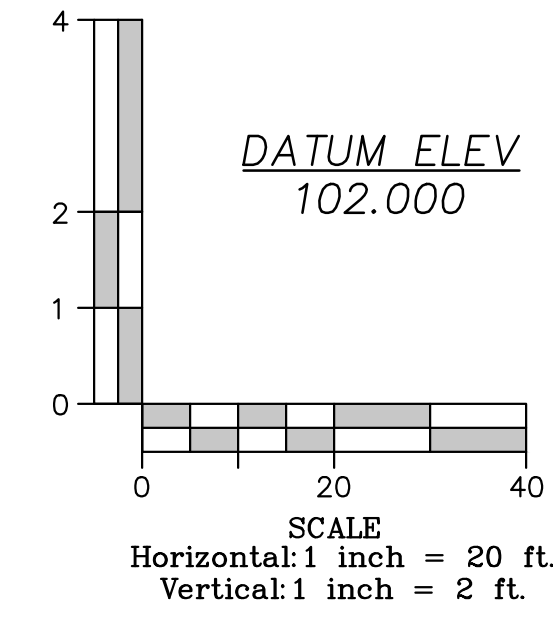

**INSERT**  
 SCALE: 1" = 10' (HORIZONTAL)

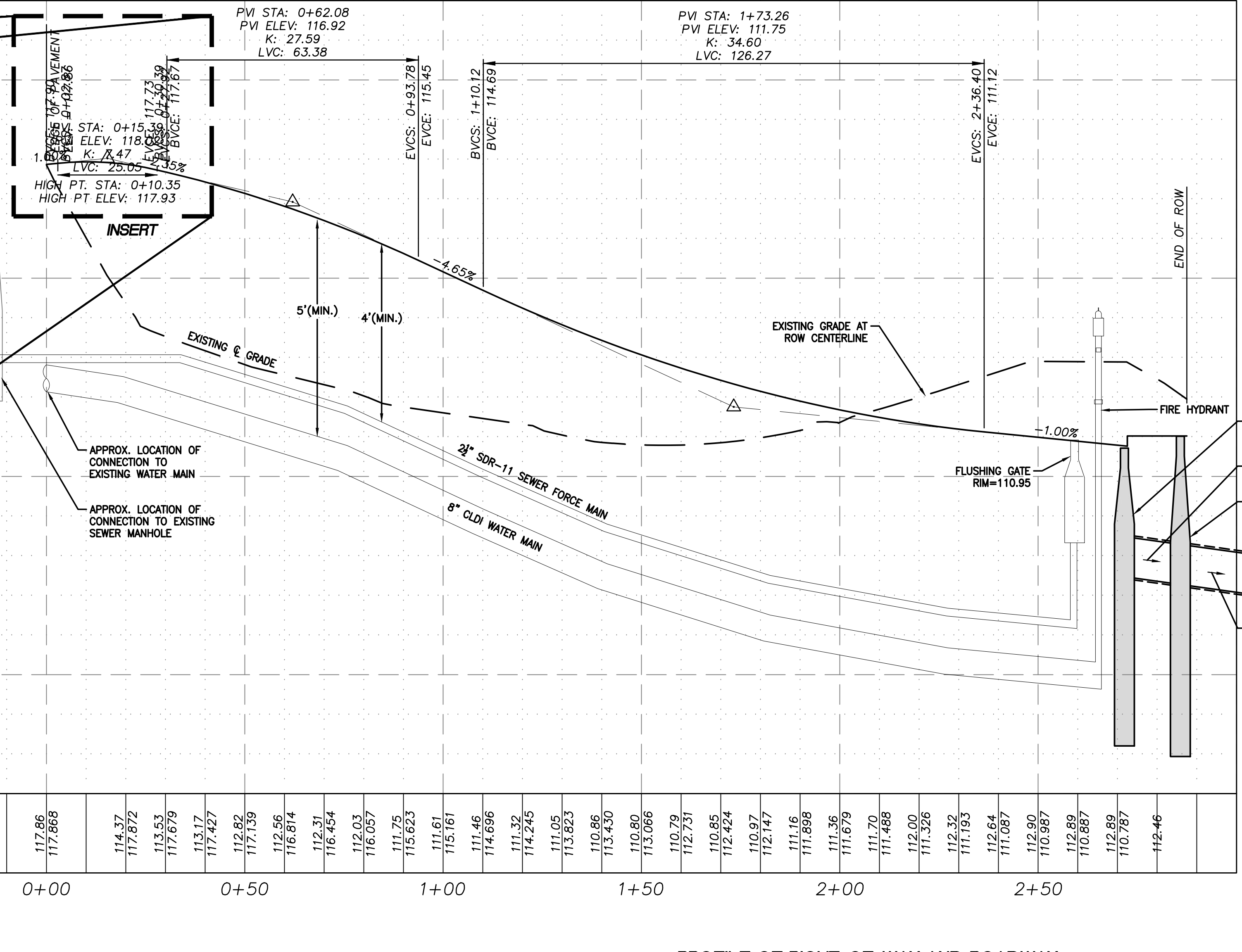
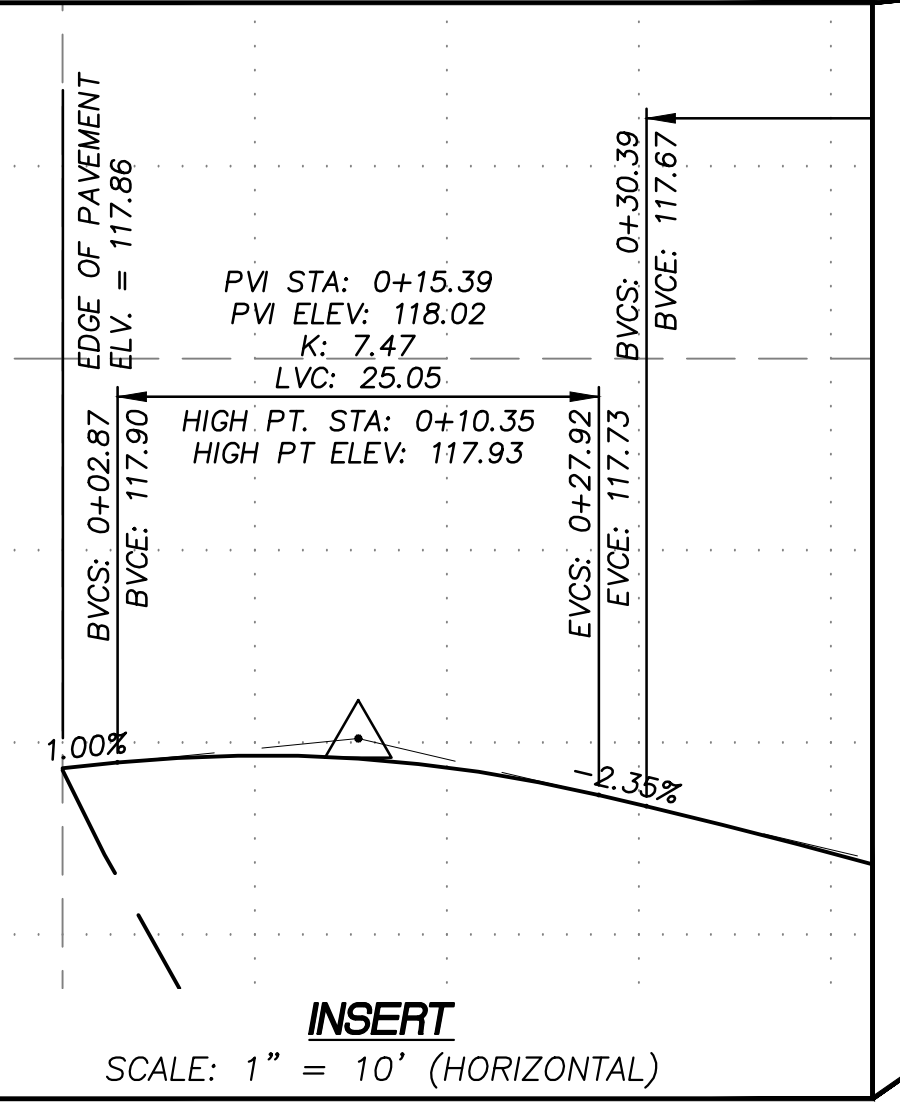

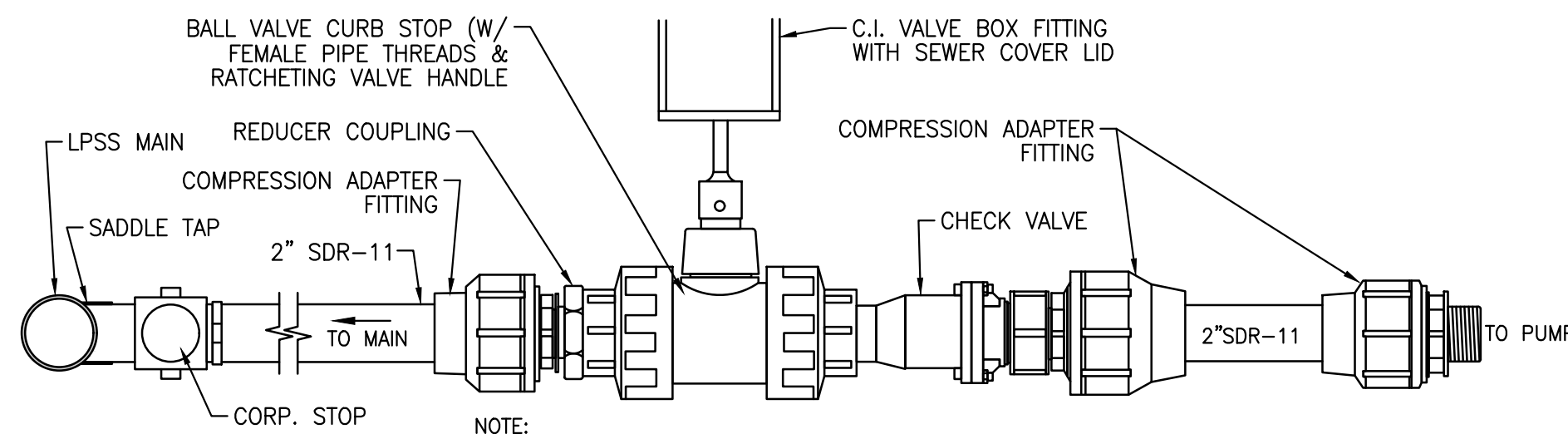

**LOW PRESSURE SEWER SERVICE LATERAL VALVE AND CONNECTION**  
N.T.S.

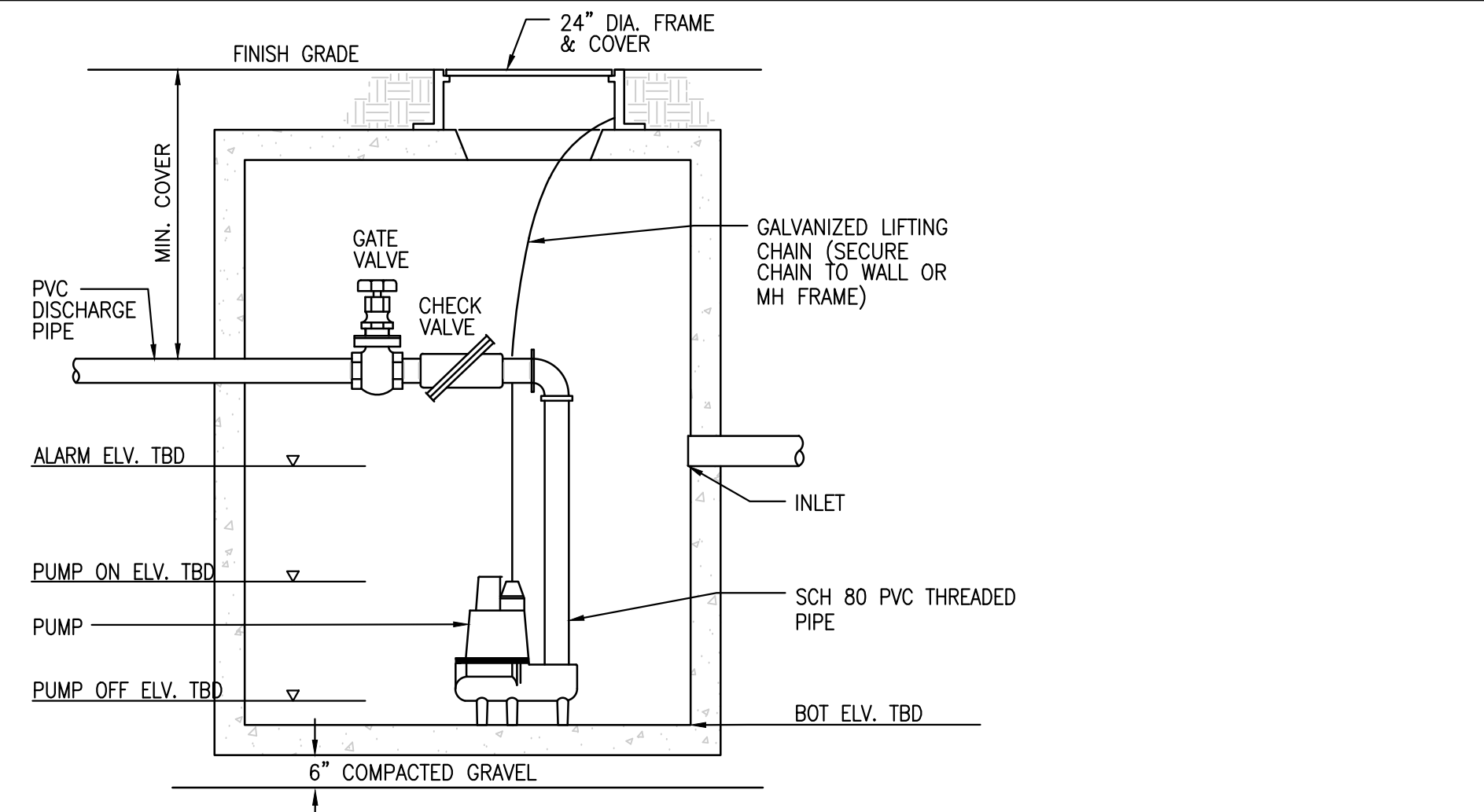

**PUMP CHAMBER**  
N.T.S.

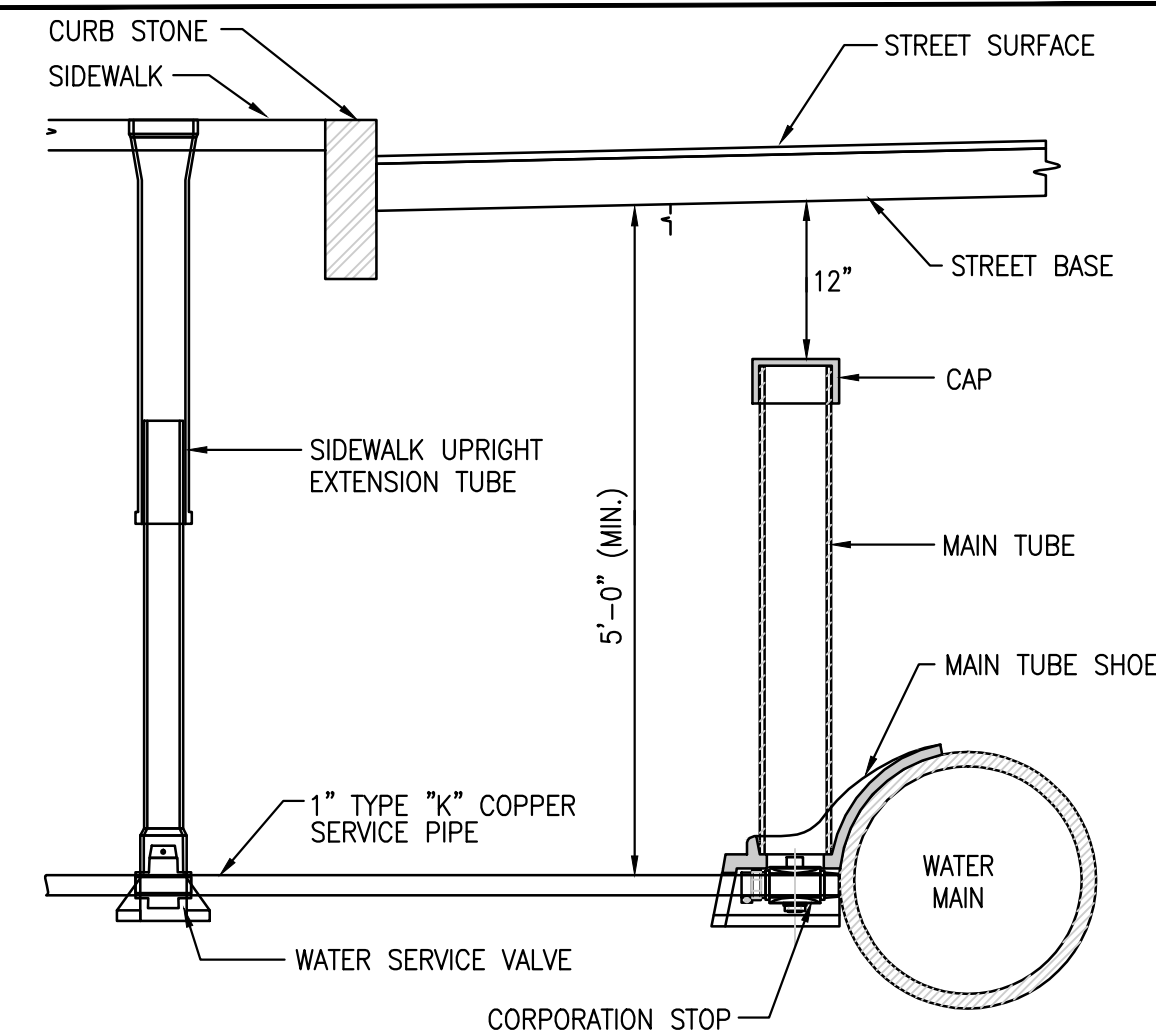

**TYPICAL WATER SERVICE CONNECTION**  
N.T.S.

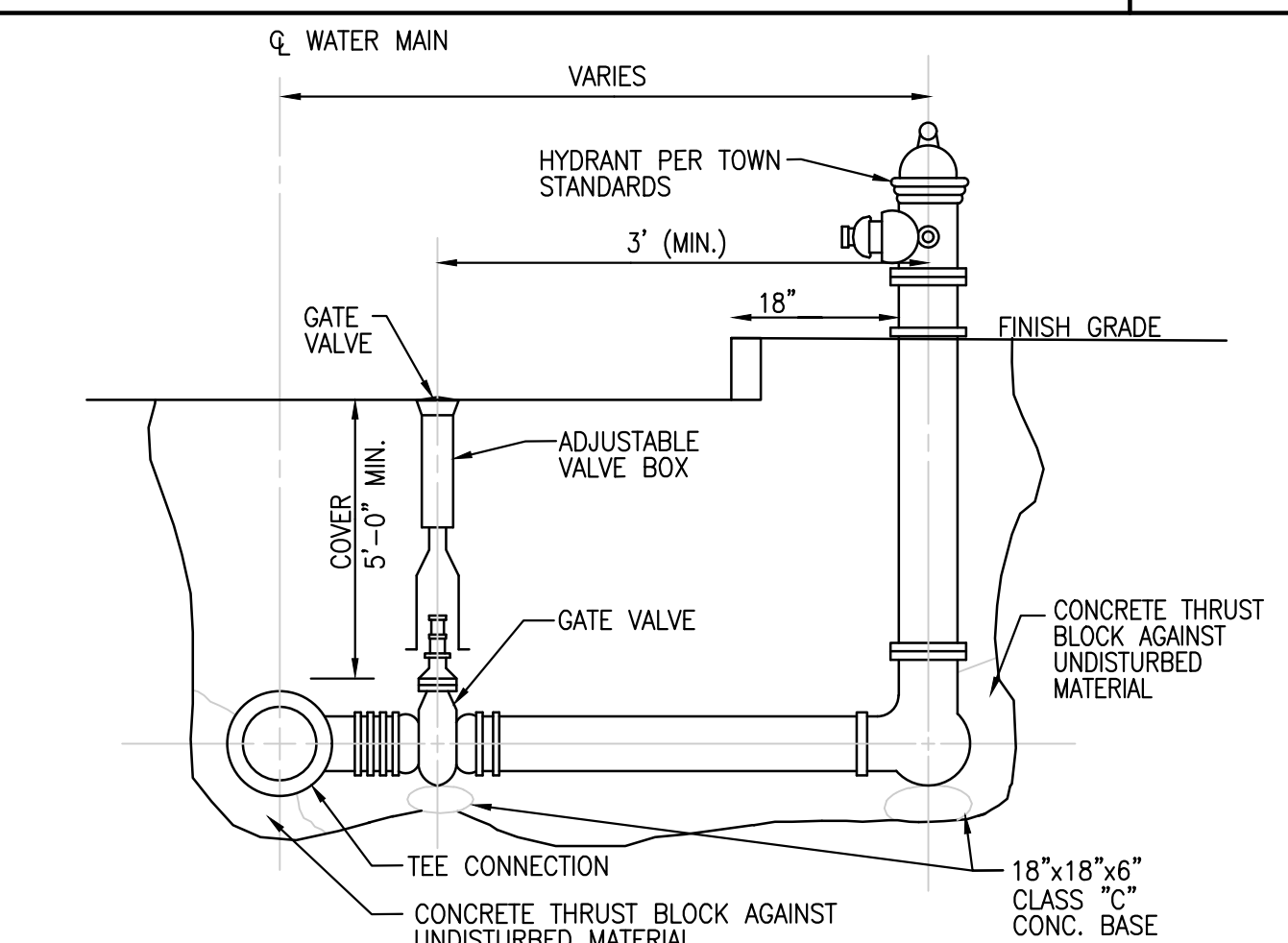

**PROPOSED FIRE HYDRANT**  
N.T.S.

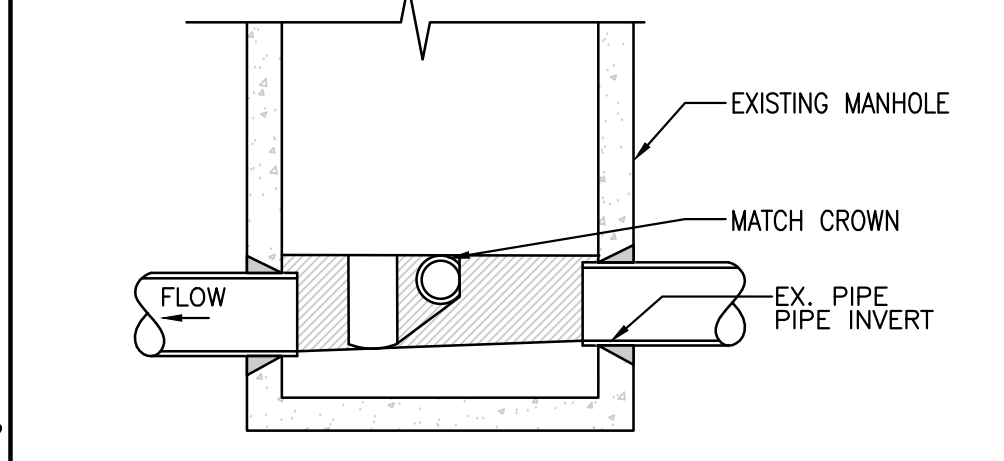

**CONNECTION TO EXISTING SEWER MANHOLE**  
N.T.S.

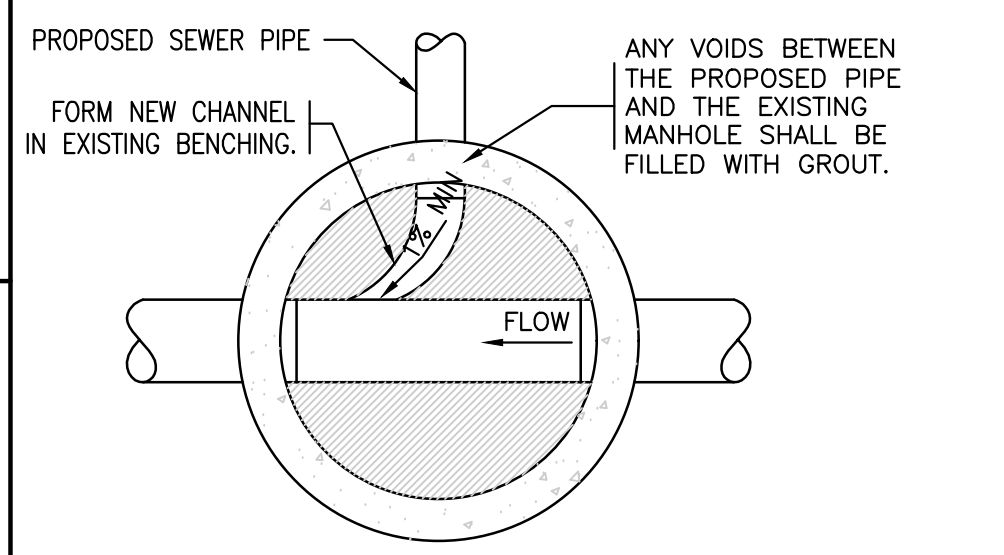

**RESTRAINED MECHANICAL JOINT FITTING**  
N.T.S.

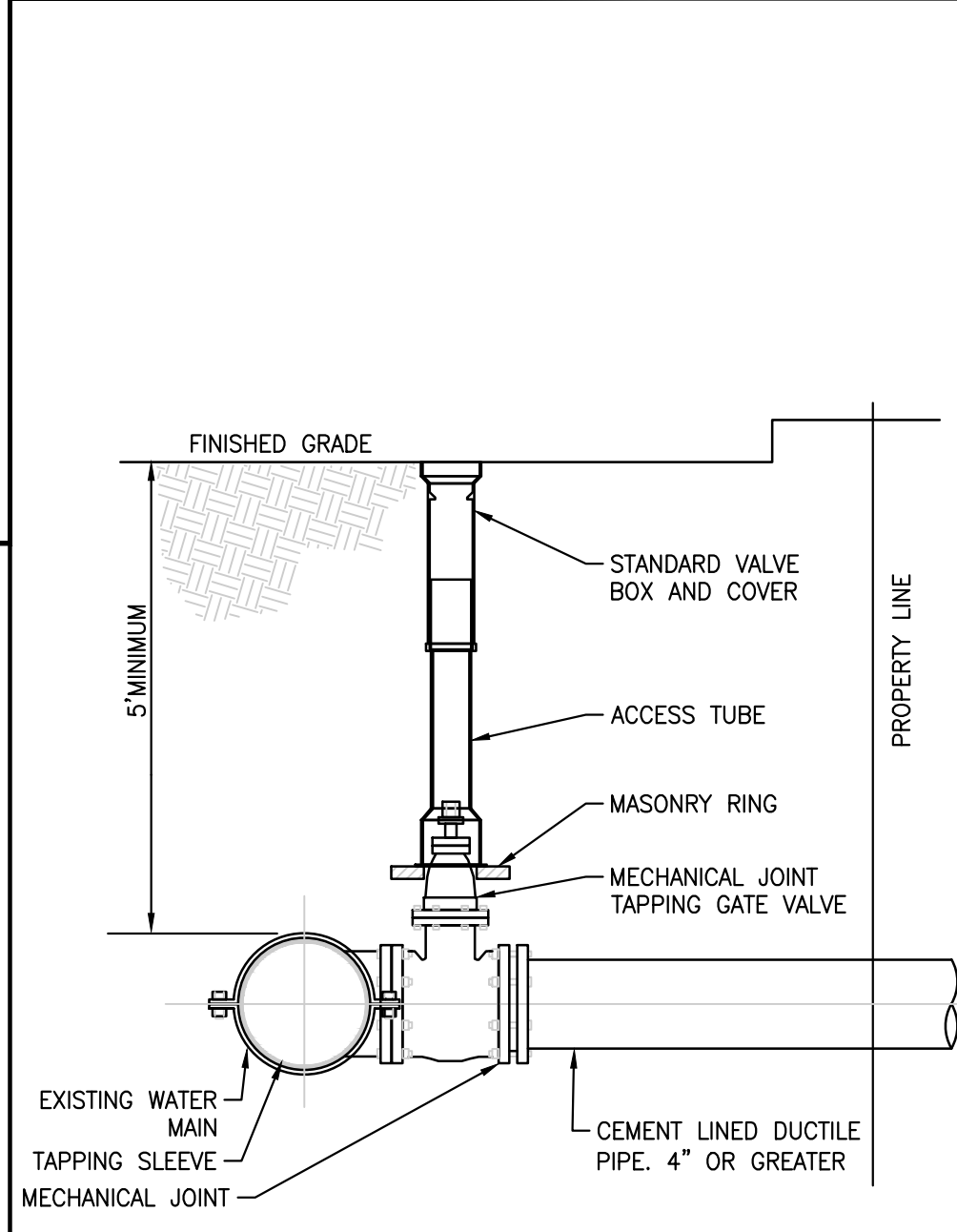

**WATER CONNECTION WITH TAPPING SLEEVE AND VALVE**  
N.T.S.

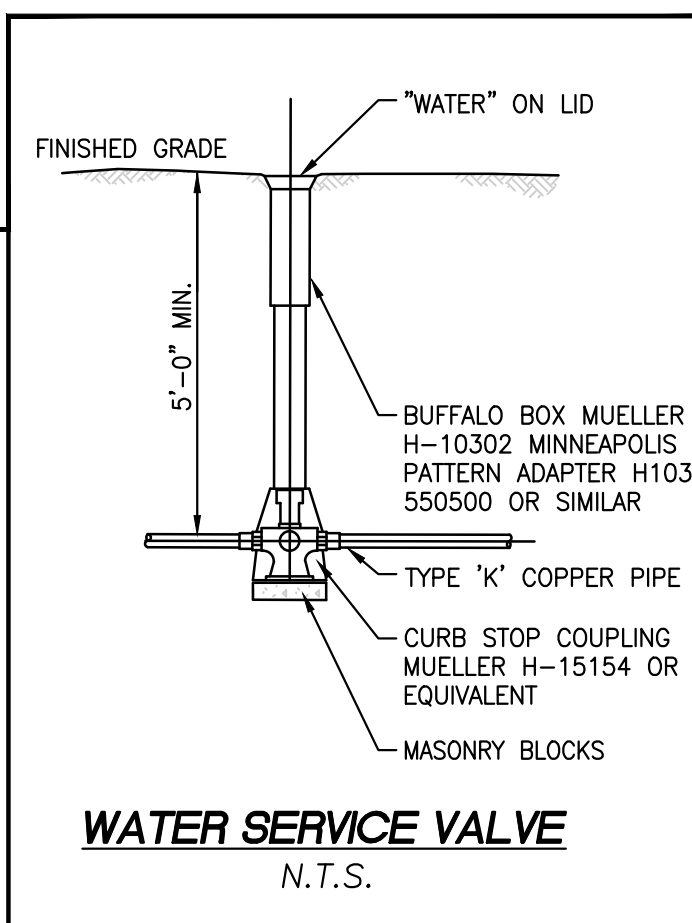

**WATER SERVICE VALVE**  
N.T.S.

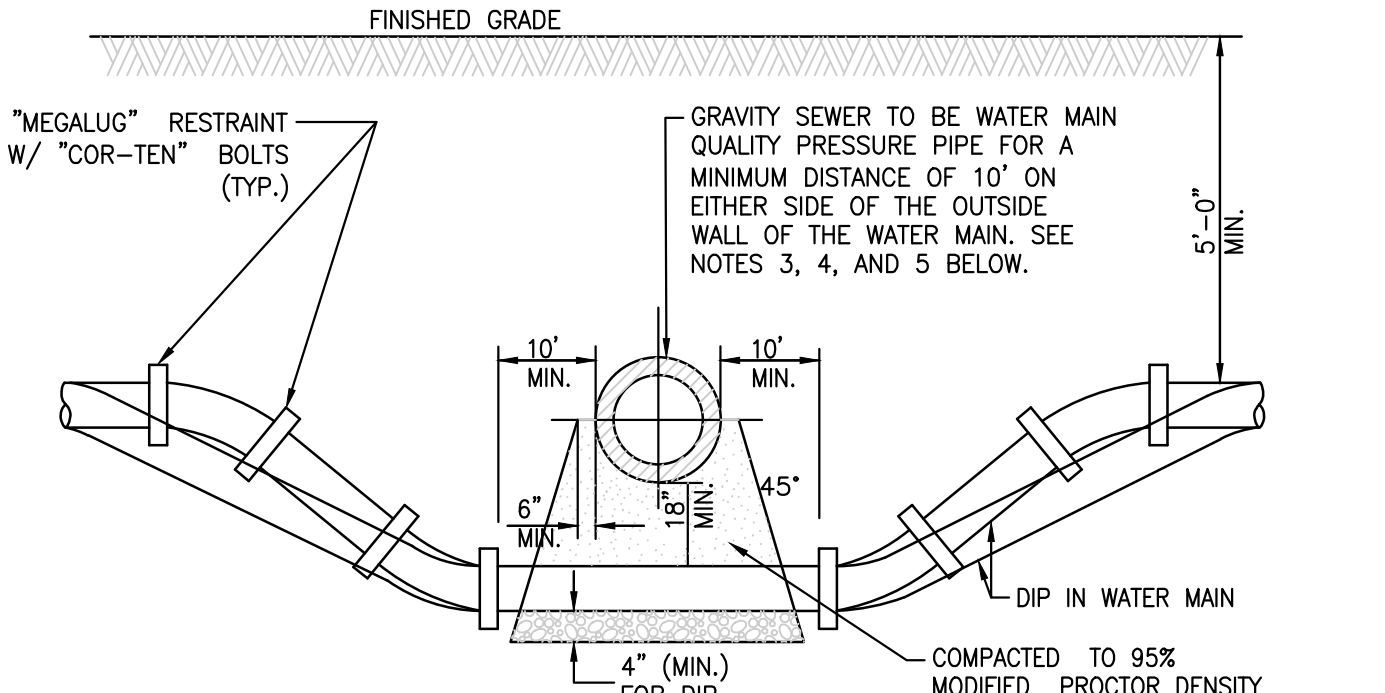

- NOTES:**
- HORIZONTAL AND VERTICAL SEPARATION BETWEEN WATERMAINS AND SEWERS SHALL COMPLY WITH APPLICABLE SECTIONS OF LOCAL OR STATE REQUIREMENTS, WHICHEVER IS MORE STRINGENT.
  - CONTRACTOR MAY BEND WATER MAIN PIPE UNIFORMLY UNDER SEWERS WITHOUT USING FITTINGS, PROVIDED THAT JOINT DEFLECTION DOES NOT EXCEED 5 DEGREES PER JOINT FOR PIPE UNDER 14" IN DIAMETER AND 3 DEGREES PER JOINT FOR PIPE 14" AND OVER IN DIAMETER. IF FITTINGS ARE USED, CONTINUOUS STRAPPING WITH RODS, STRAPS, NUTS AND BOLTS BELOW NORMAL WATERMAIN DEPTH ARE REQUIRED, OR RETAINER GLANDS MAY BE USED IN LIEU OF STRAPPING. RETAINER GLANDS TO BE CLOW No. F-1058 OR APPROVED EQUAL.
  - ALL SANITARY SEWER (INCLUDING SERVICE) CROSSINGS WHERE THE WATER MAINS OR WATER SERVICES ARE LESS THAN 18" VERTICALLY ABOVE THE SEWER SHALL BE POLYVINYL CHLORIDE PRESSURE PIPE (SDR 26-160 PSI) AND SHALL CONFORM WITH THE LATEST REVISION OF ASTM D-2241. JOINTS SHALL CONFORM TO ASTM D-3139 AND ELASTOMERIC GASKETS SHALL CONFORM TO ASTM F-477. THE SAME PIPE AND JOINT MATERIALS SHALL BE USED WHENEVER WATER MAIN CROSSES BELOW THE SEWER.
  - ALL STORM SEWER (INCLUDING SERVICE) CROSSINGS WHERE THE WATER MAINS ARE LESS THAN 18" VERTICALLY ABOVE THE SEWER SHALL BE REINFORCED CONCRETE PIPE, ASTM C-361, CLASS D-25, WITH BELL AND SPIGOT JOINTS AND RUBBER GASKETS, OR PVC SDR 26 AS SPECIFIED IN NOTE 3 ABOVE. THE SAME PIPE AND JOINT MATERIAL SHALL BE USED WHENEVER WATER MAIN CROSSES BELOW THE SEWER.
  - FOR NEW SEWER INSTALLATIONS CROSSING OVER WATER MAINS, THE ENTIRE RUN OF NEW SEWER SHALL BE WATER MAIN QUALITY PIPE, EXTENDING FROM STRUCTURE TO STRUCTURE ON EACH SIDE OF THE CROSSING.

**WATER MAIN CROSSING**  
N.T.S.

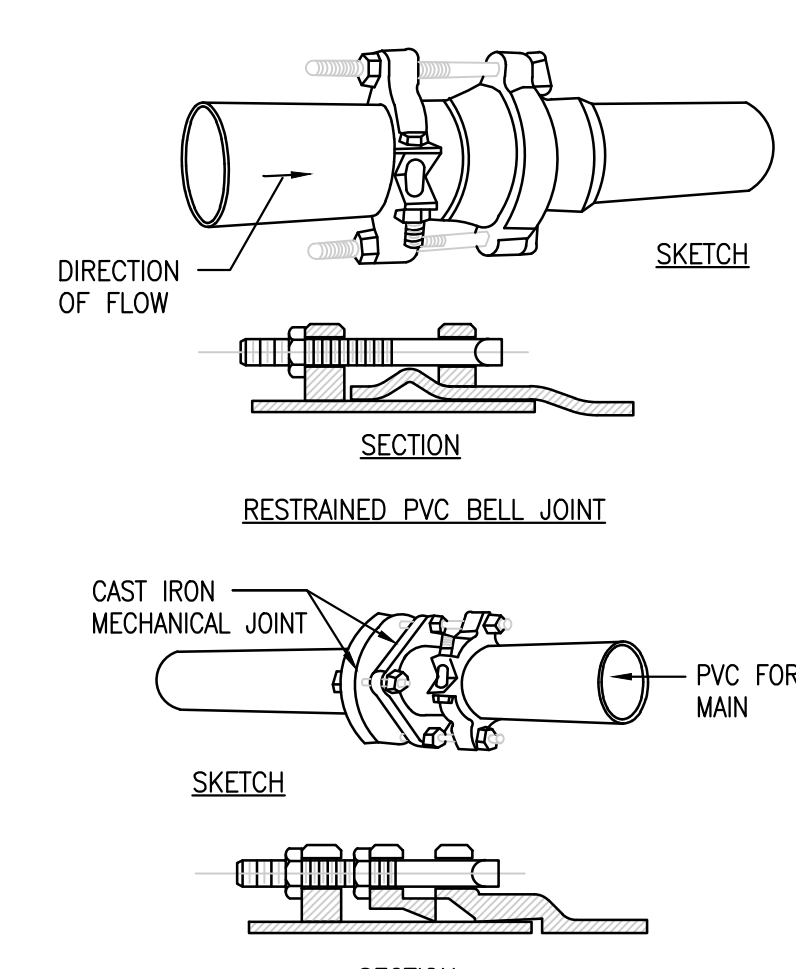

**SEWER FORCE MAIN FLUSHING CONNECTION**  
N.T.S.

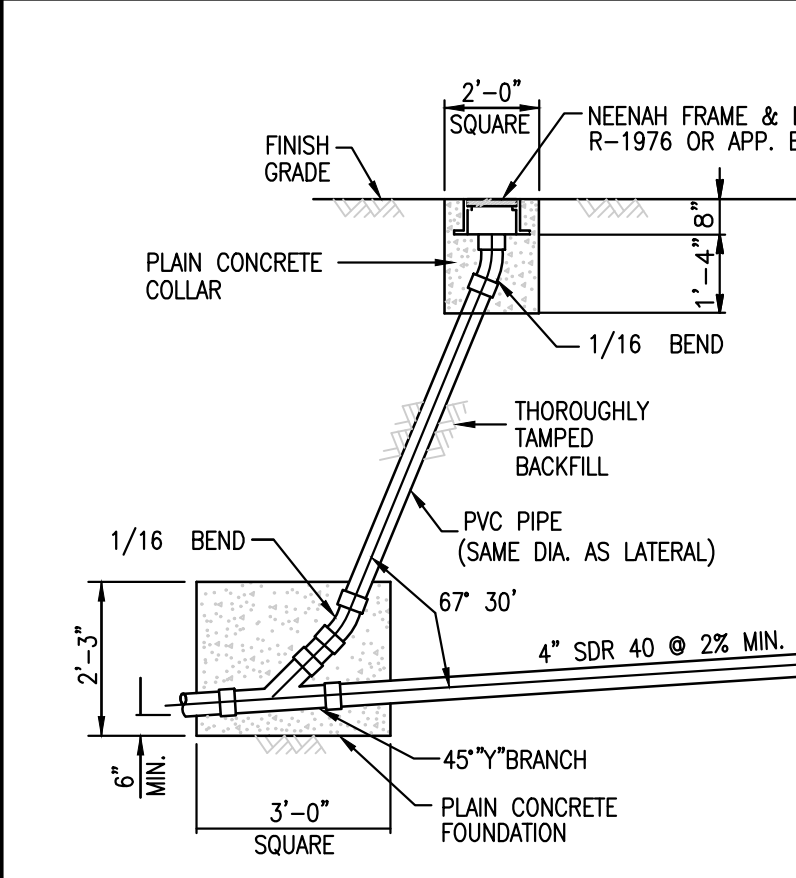

**SEWER SERVICE AT BUILDING W/ CLEANOUT**  
N.T.S.

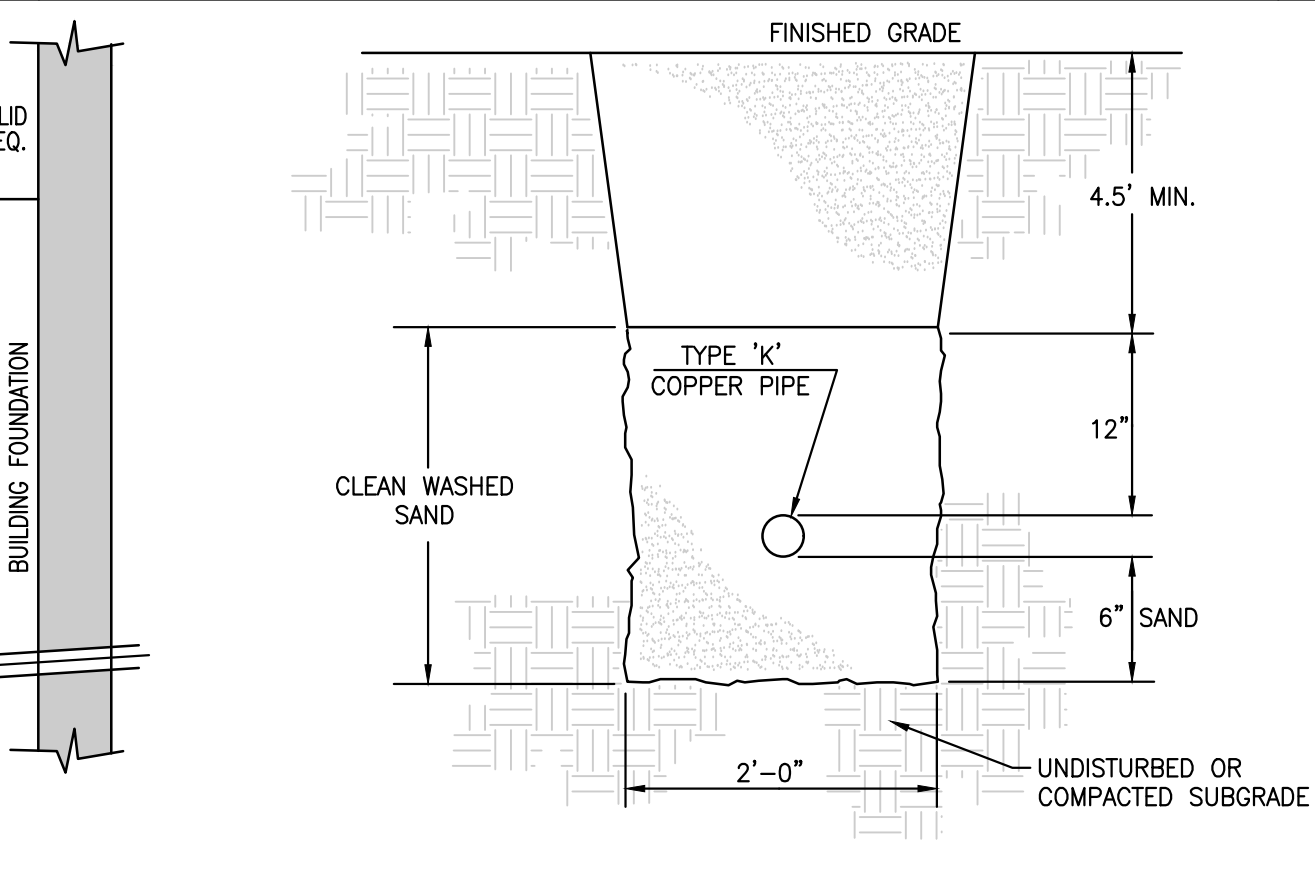

**COPPER WATER SERVICE PIPE TRENCH**  
N.T.S.

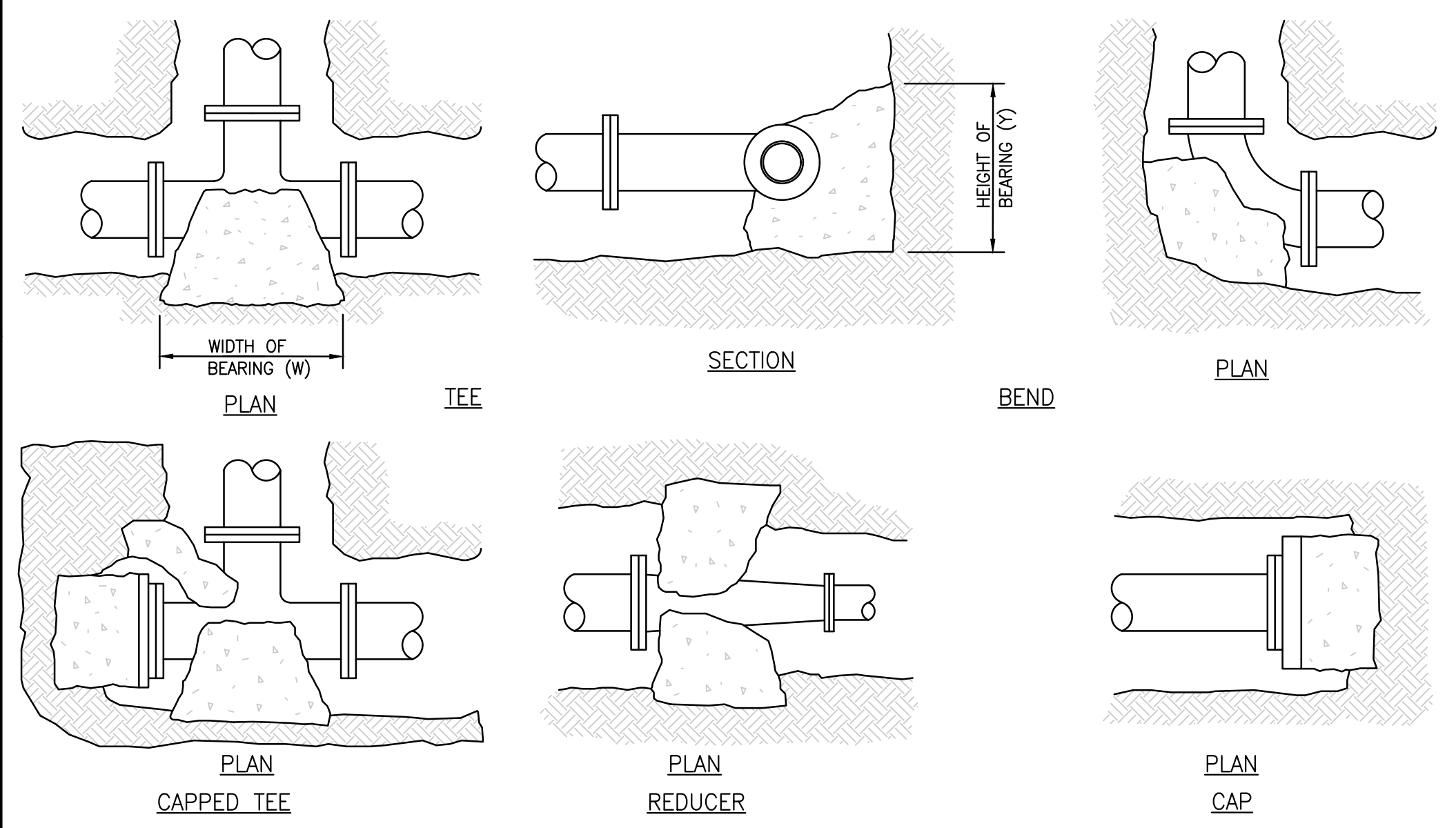

**MINIMUM THRUST BLOCK AREA REQUIRED (Y x W)**

PIPE SIZE	WATER PIPE	
	TEE, DEAD END, 90° BEND	45° & 22-8° BENDS
4" OR LESS	3 SQ. FEET	3 SQ. FEET
6"	4 SQ. FEET	3 SQ. FEET
8"	6 SQ. FEET	3 SQ. FEET
10"	9 SQ. FEET	5 SQ. FEET
12"	13 SQ. FEET	7 SQ. FEET
16"	23 SQ. FEET	12 SQ. FEET

- NOTES:**
- THRUST BLOCKS TO EXTEND TO UNDISTURBED GROUND.
  - ALL CONCRETE SHALL BE CLASS B.
  - TABLE IS BASED ON 3000 LB./SQ. FT. SOIL. IF SOIL CONDITIONS ARE FOUND TO INDICATE SOIL BEARING LESS, THE AREAS SHALL BE INCREASED ACCORDINGLY.
  - AREAS FOR PIPES GREATER THAN 16" SHALL BE CALCULATED FOR EACH PROJECT.
  - FOR ALL NON BEARING VERTICAL SURFACES.

**THRUST BLOCKS FOR WATER SYSTEM**  
N.T.S.

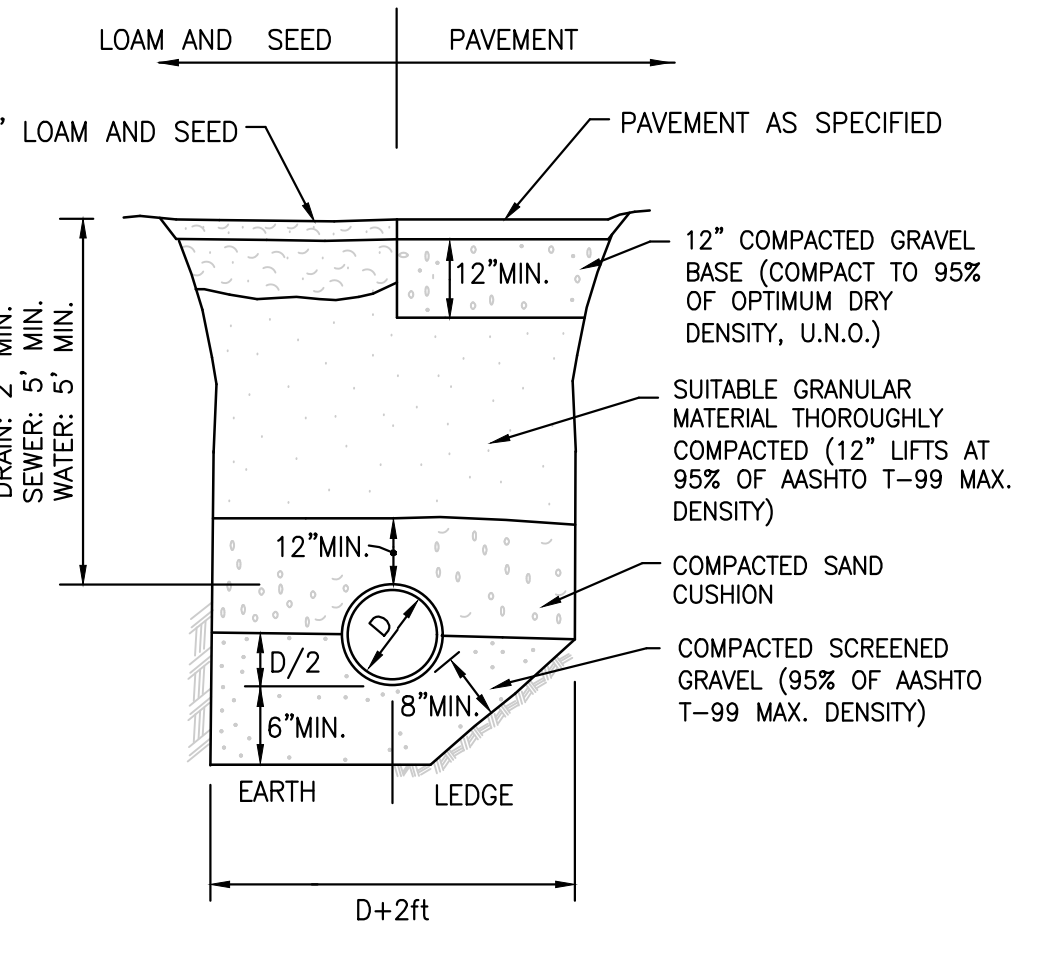

**DRAIN/ SEWER/ WATER TRENCH AND BACKFILL DETAIL**  
N.T.S.

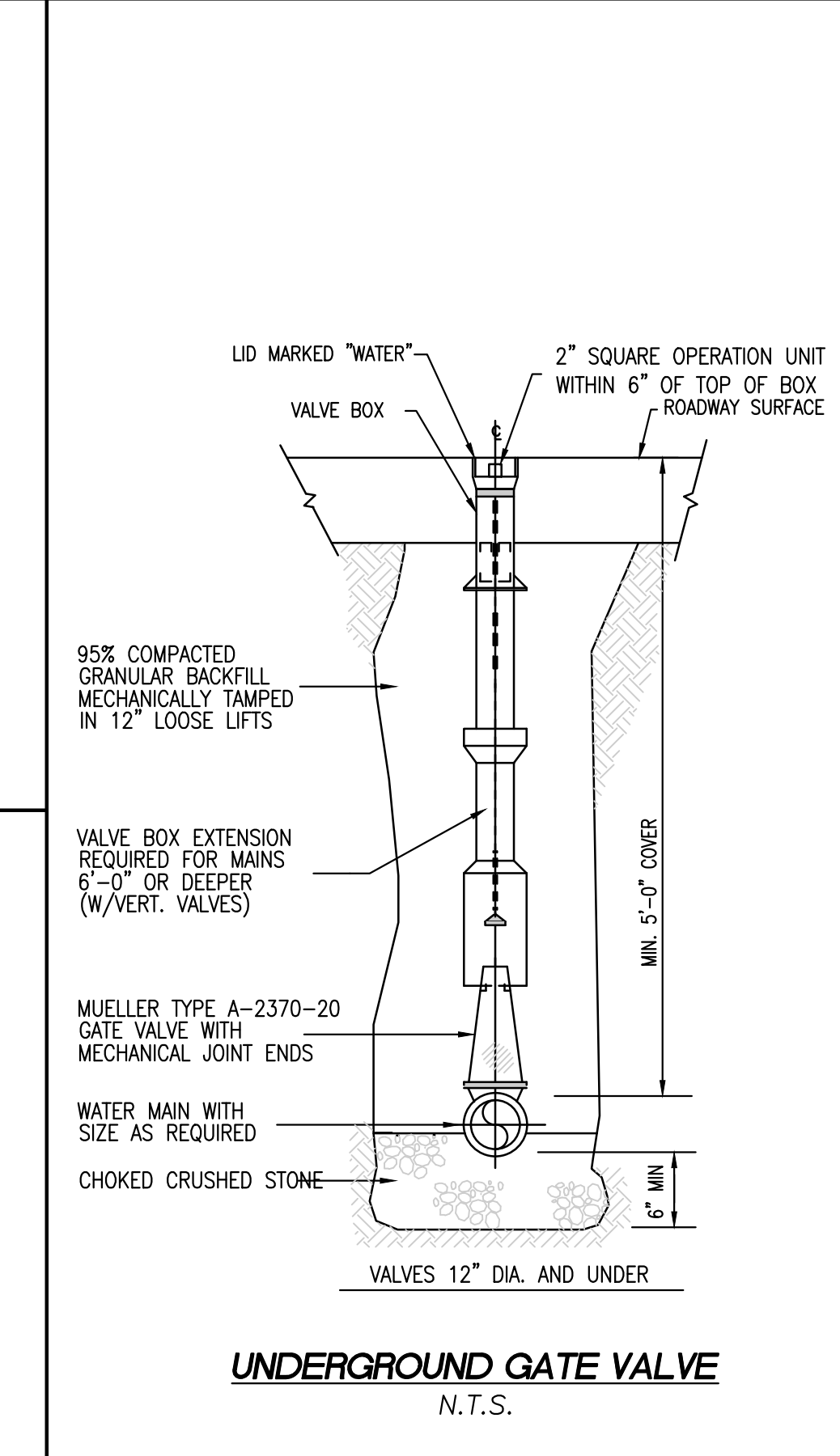

**UNDERGROUND GATE VALVE**  
N.T.S.

TOWN OF READING  
COMMUNITY PLANNING & DEVELOPMENT COMMISSION  
DATE: \_\_\_\_\_  
FOR REGISTRY USE ONLY

**ENGINEER:** FODERA ENGINEERING  
(617)877-3293  
gfodera@foderaengineering.com  
28 Harbor St., Suite 204  
Danvers, MA 01923

**SURVEYOR:** PFS Land Surveying, Inc.  
30 Balch Avenue  
Groveland, MA 01834  
P.978.891.5203  
www.pfsland.com

PROFESSIONAL SEAL  
GIOVANNI GAETANO FODERA  
No. 54884  
REGISTERED PROFESSIONAL ENGINEER

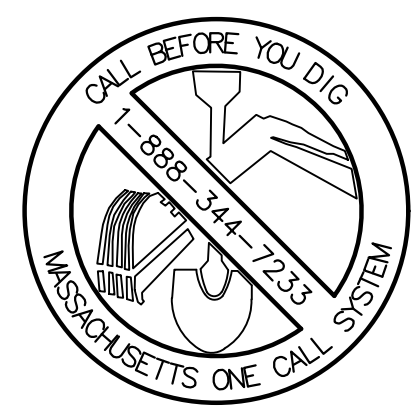

REVISION	DATE	BY

PROJECT LOCATION:  
LOTS 2, 3, & 4  
GRANDVIEW ROAD  
READING, MA 01867  
PARCEL ID:  
MAP 27, LOT 404

PLAN SET:  
**MAJOR SITE PLAN MODIFICATION  
GRANDVIEW ROAD SUBDIVISION - PRIVATE WAY  
(GRANDVIEW ROAD EXTENSION)**  
SCALE: N.T.S.  
APRIL 20, 2023  
SITE PLAN PERMIT SET

FOR REGISTRY USE ONLY

**COPYRIGHT NOTICE**  
This drawing is property of Fodera Engineering and is not to be used for any purpose other than the specific project and site named herein, and cannot be reproduced in any manner without the express written permission from the engineer on record.

JOB NO.: 20160-149  
**SHEET TITLE:**  
DETAILS  
SHEET 1  
**SHEET NUMBER:**  
C-6

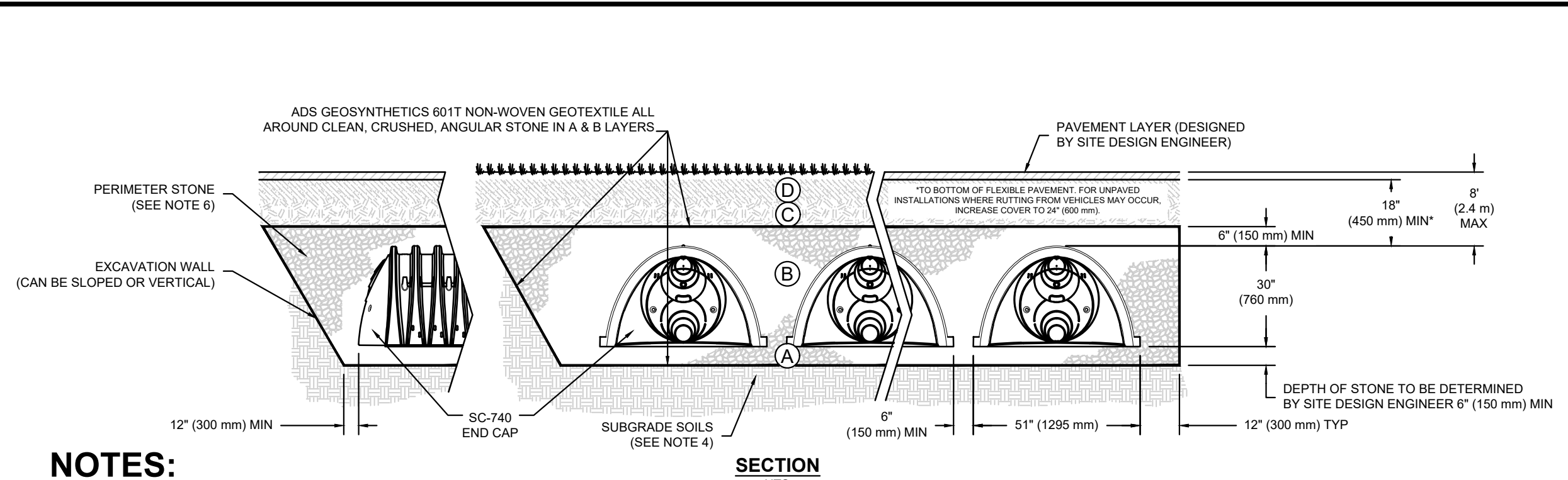
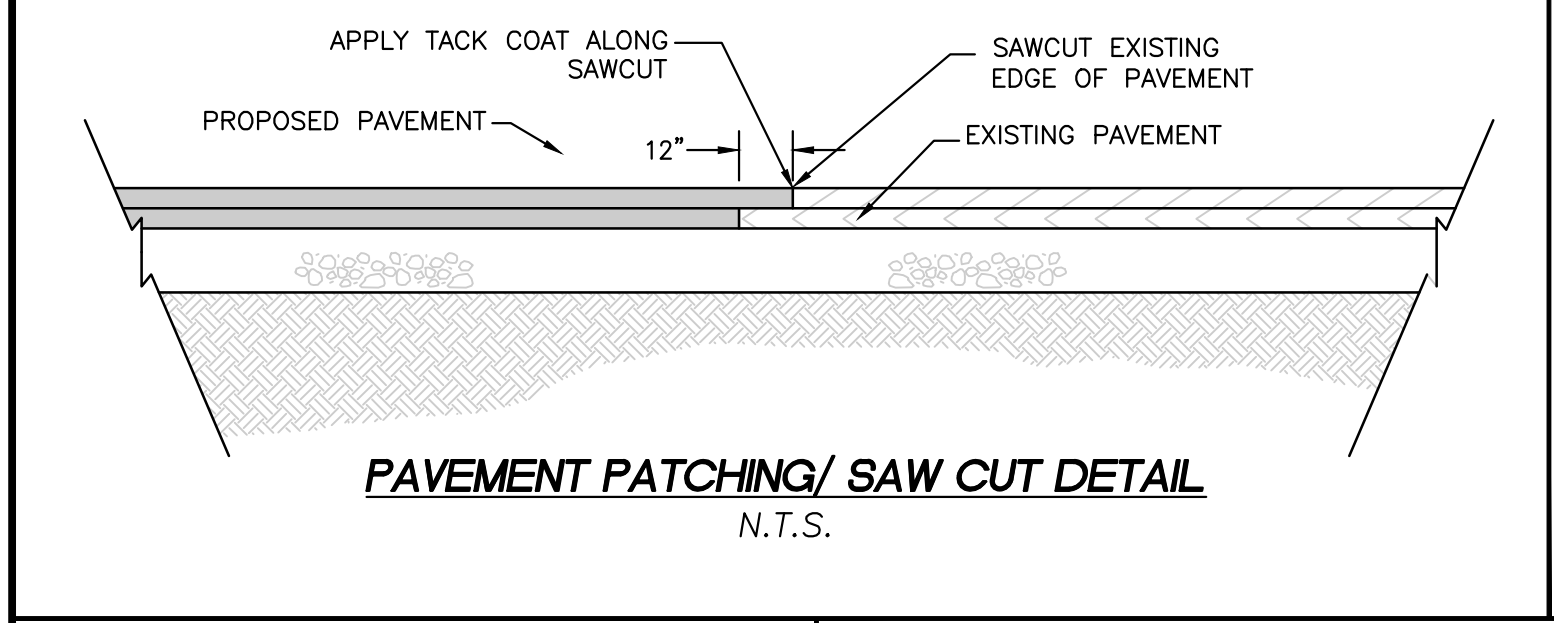
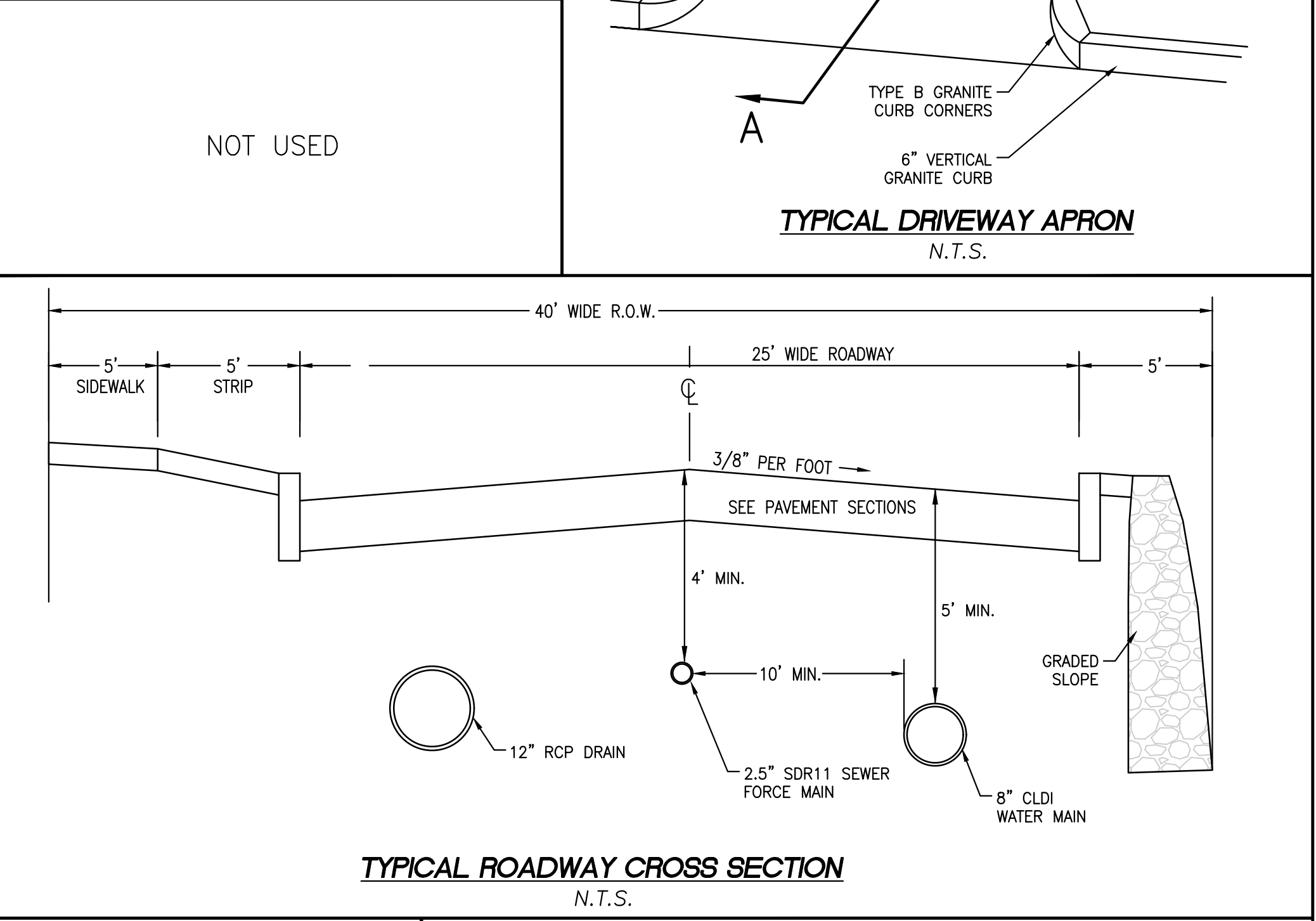
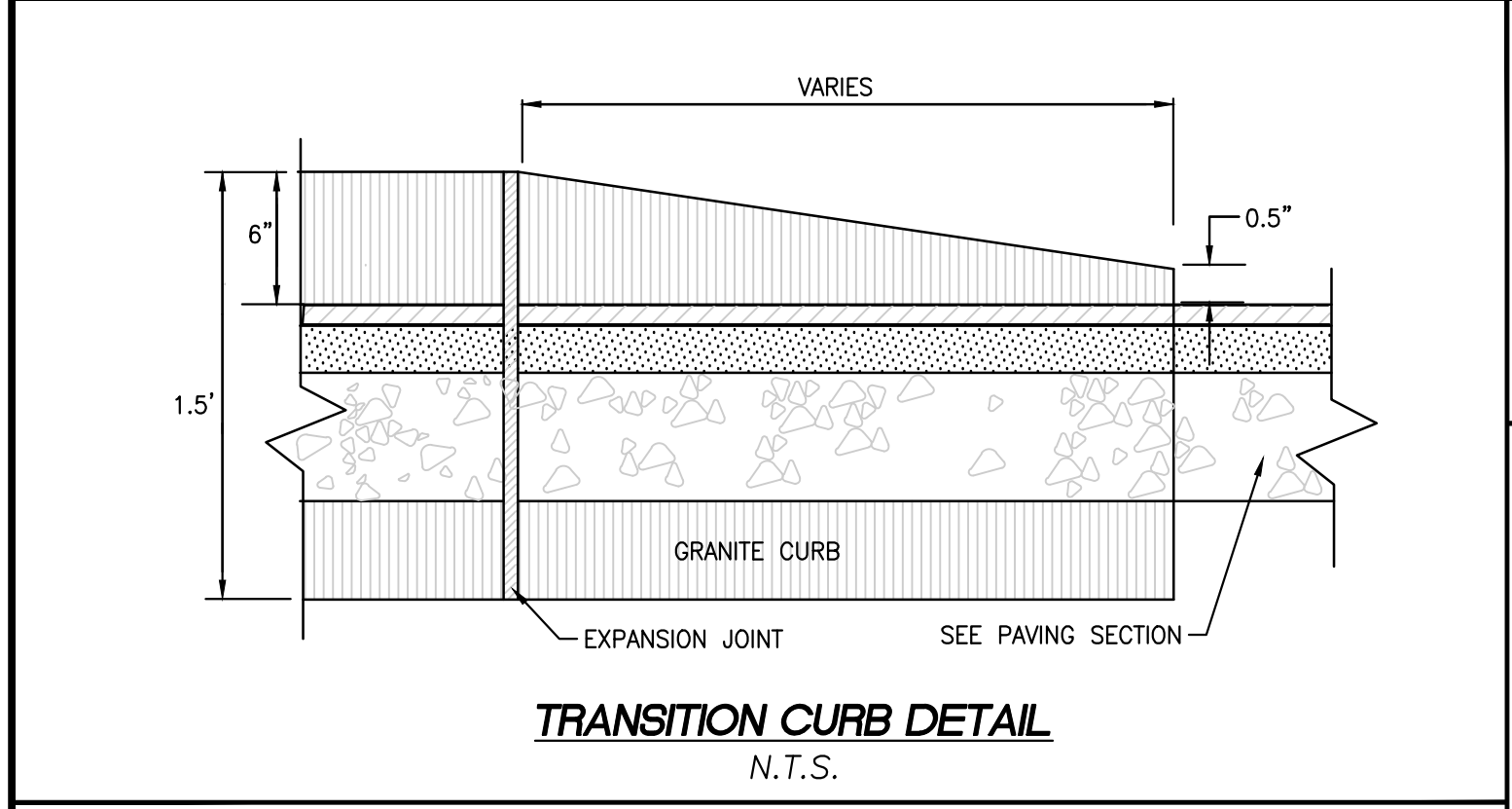
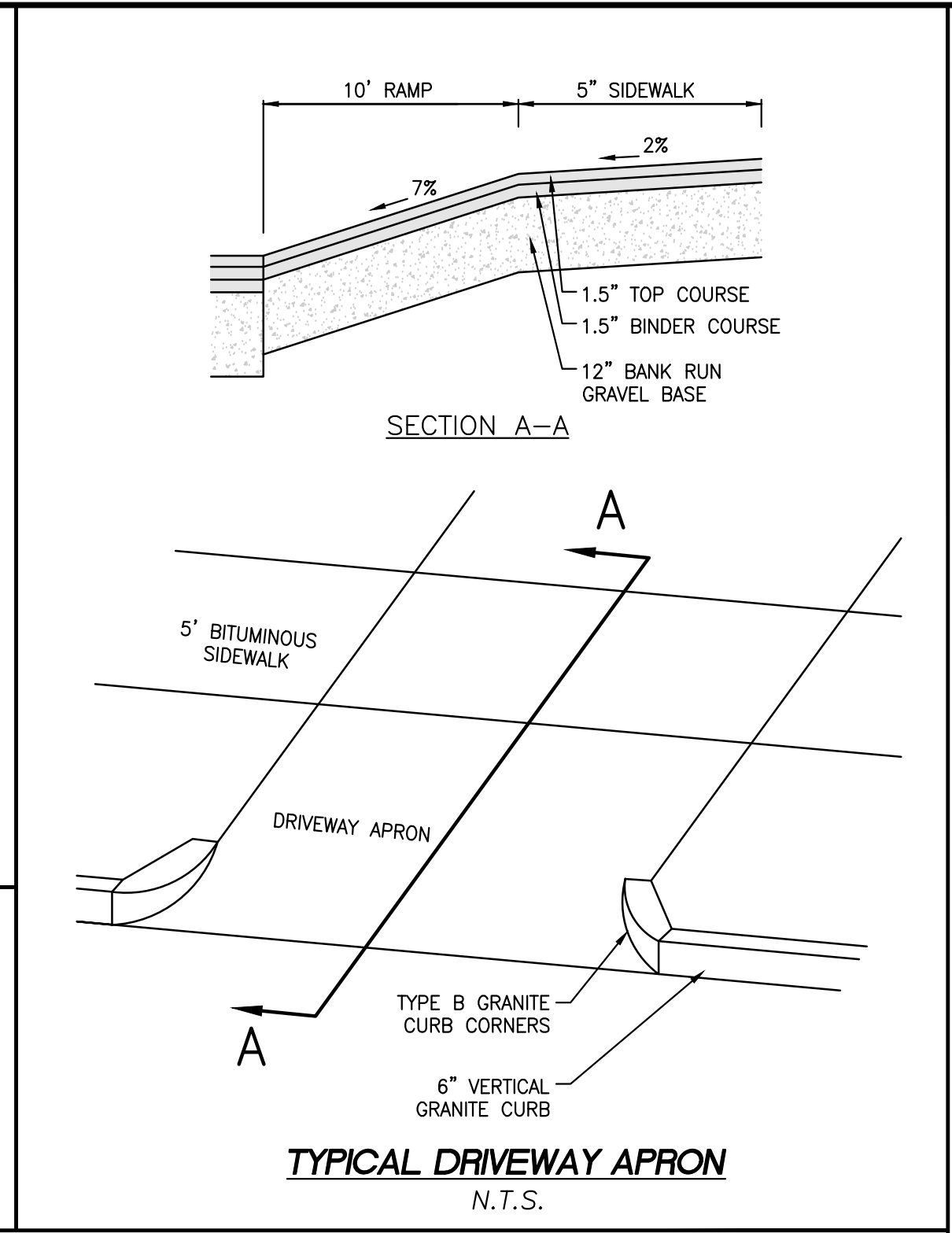
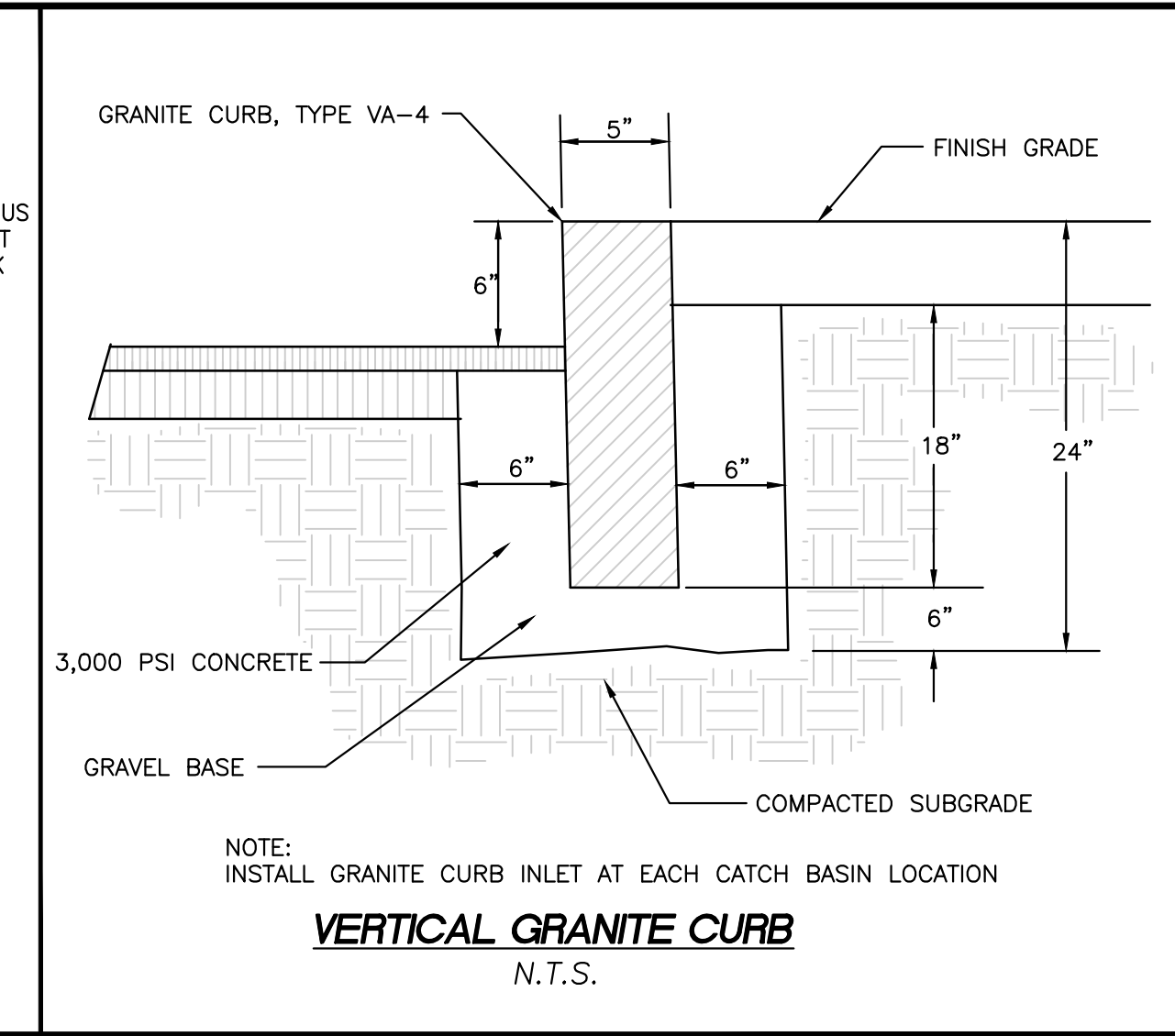
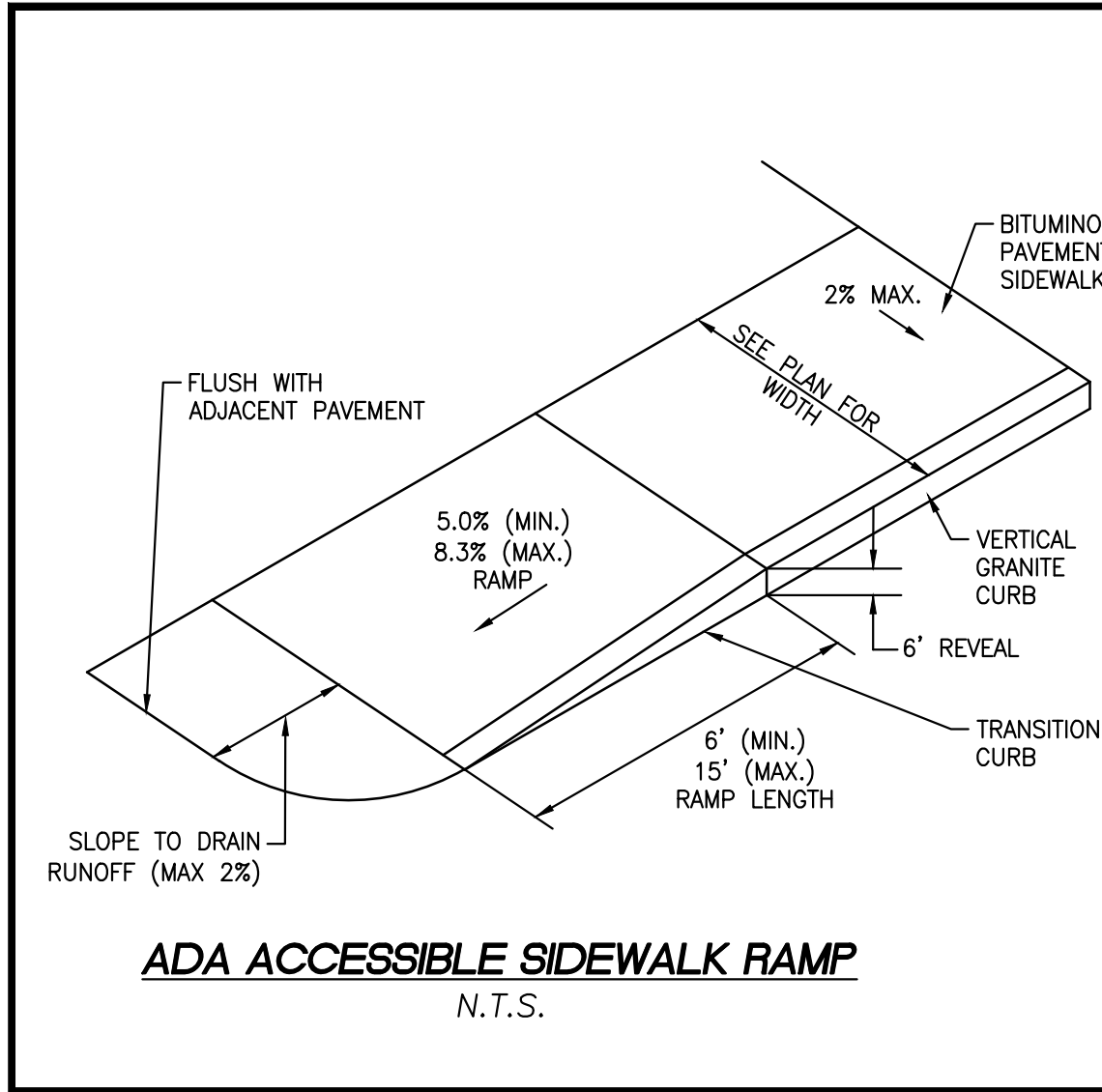

- NOTES:**
- SC-740 CHAMBERS SHALL BE DESIGNED IN ACCORDANCE WITH ASTM F2787 "STANDARD PRACTICE FOR STRUCTURAL DESIGN OF THERMOPLASTIC CORRUGATED WALL STORMWATER COLLECTION CHAMBERS".
  - "ACCEPTABLE FILL MATERIALS" TABLE ABOVE PROVIDES MATERIAL LOCATIONS, DESCRIPTIONS, GRADATIONS, AND COMPACTION REQUIREMENTS FOR FOUNDATION, EMBEDMENT, AND FILL MATERIALS.
  - THE SITE DESIGN ENGINEER IS RESPONSIBLE FOR ASSESSING THE BEARING RESISTANCE (ALLOWABLE BEARING CAPACITY) OF THE SUBGRADE SOILS AND THE DEPTH OF FOUNDATION STONE WITH CONSIDERATION FOR THE RANGE OF EXPECTED SOIL MOISTURE CONDITIONS.
  - PERIMETER STONE MUST BE EXTENDED HORIZONTALLY TO THE EXCAVATION WALL FOR BOTH VERTICAL AND SLOPED EXCAVATION WALLS.
  - ONCE LAYER 'C' IS PLACED, ANY SOIL/MATERIAL CAN BE PLACED IN LAYER 'D' UP TO THE FINISHED GRADE. MOST PAVEMENT SUBBASE SOILS CAN BE USED TO REPLACE THE MATERIAL REQUIREMENTS OF LAYER 'C' OR 'D' AT THE SITE DESIGN ENGINEER'S DISCRETION.

- (A) DOUBLE WASHED 3/4"-1 1/2" STONE
- (B) DOUBLE WASHED 3/4"-1 1/2" STONE
- (C) CLEAN GRANULAR FILL MATERIAL
- (D) 4"-6" TOPSOIL (LAWN AREA) OR 12" COMPACTED GRAVEL BASE (PAVEMENT AREA)

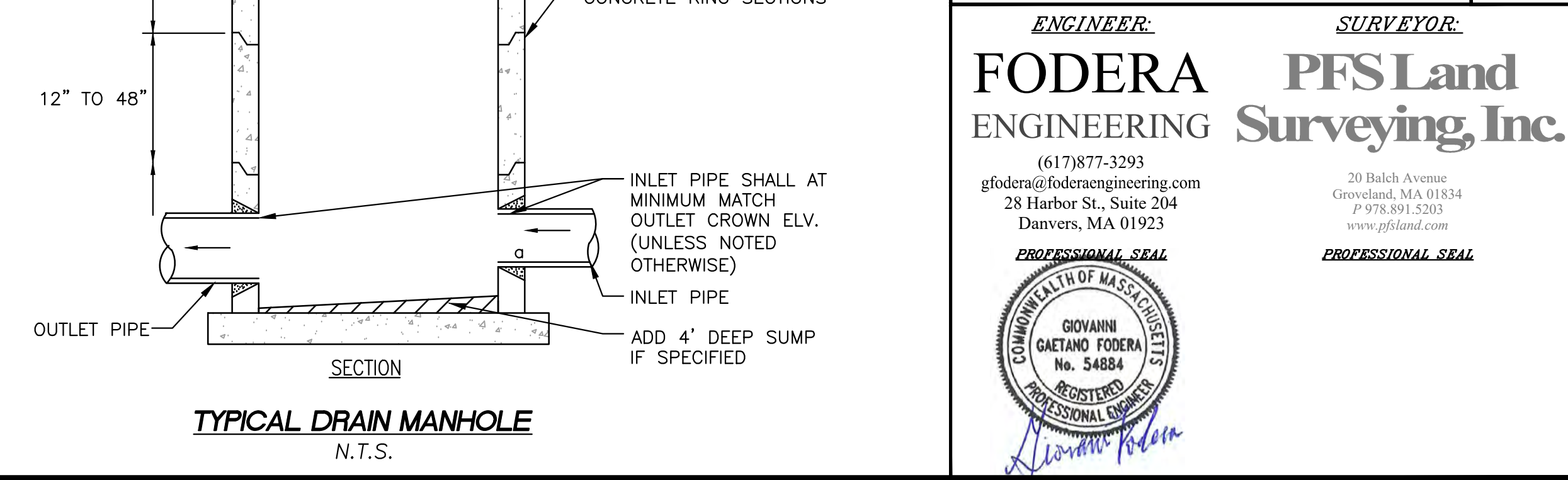
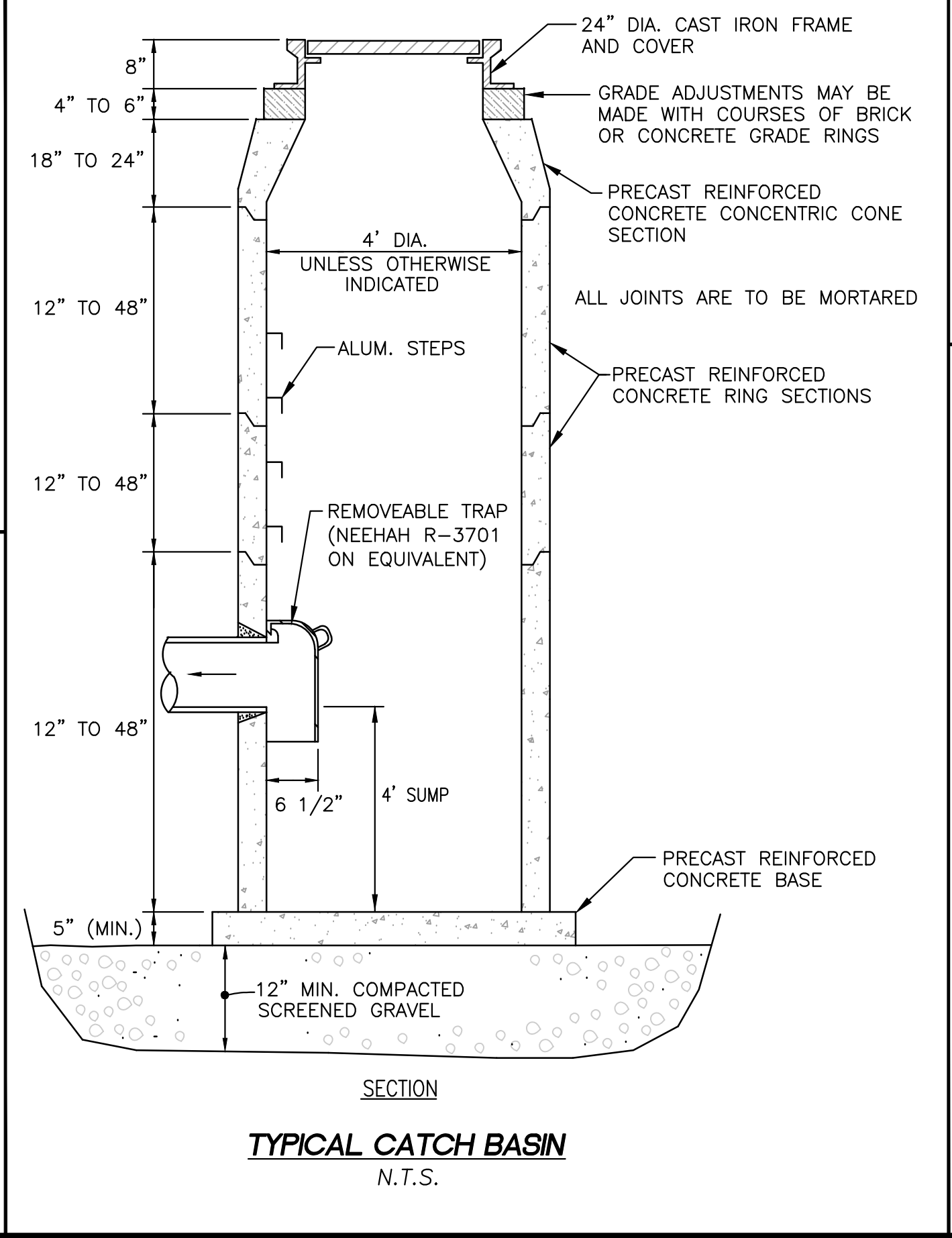
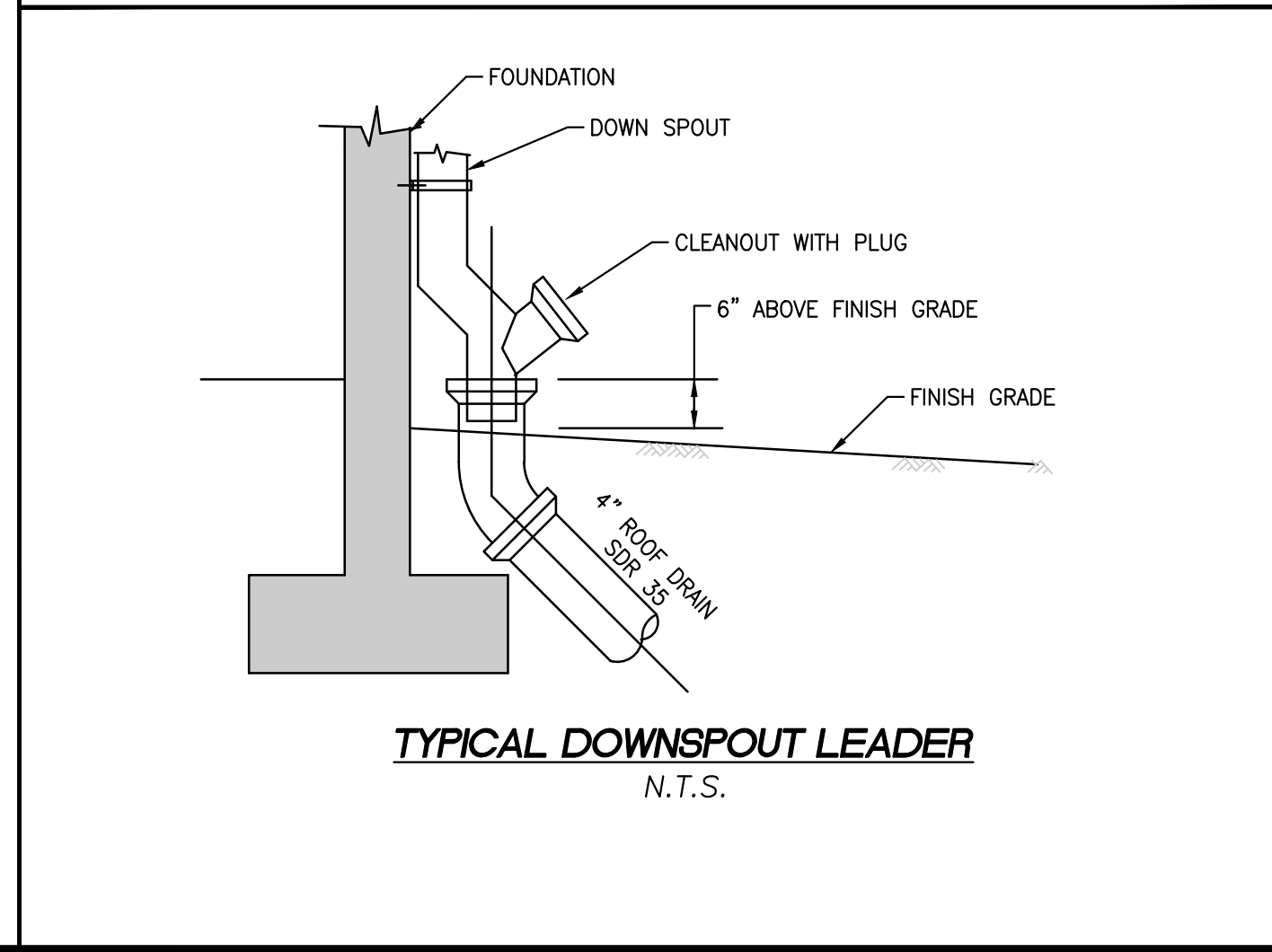
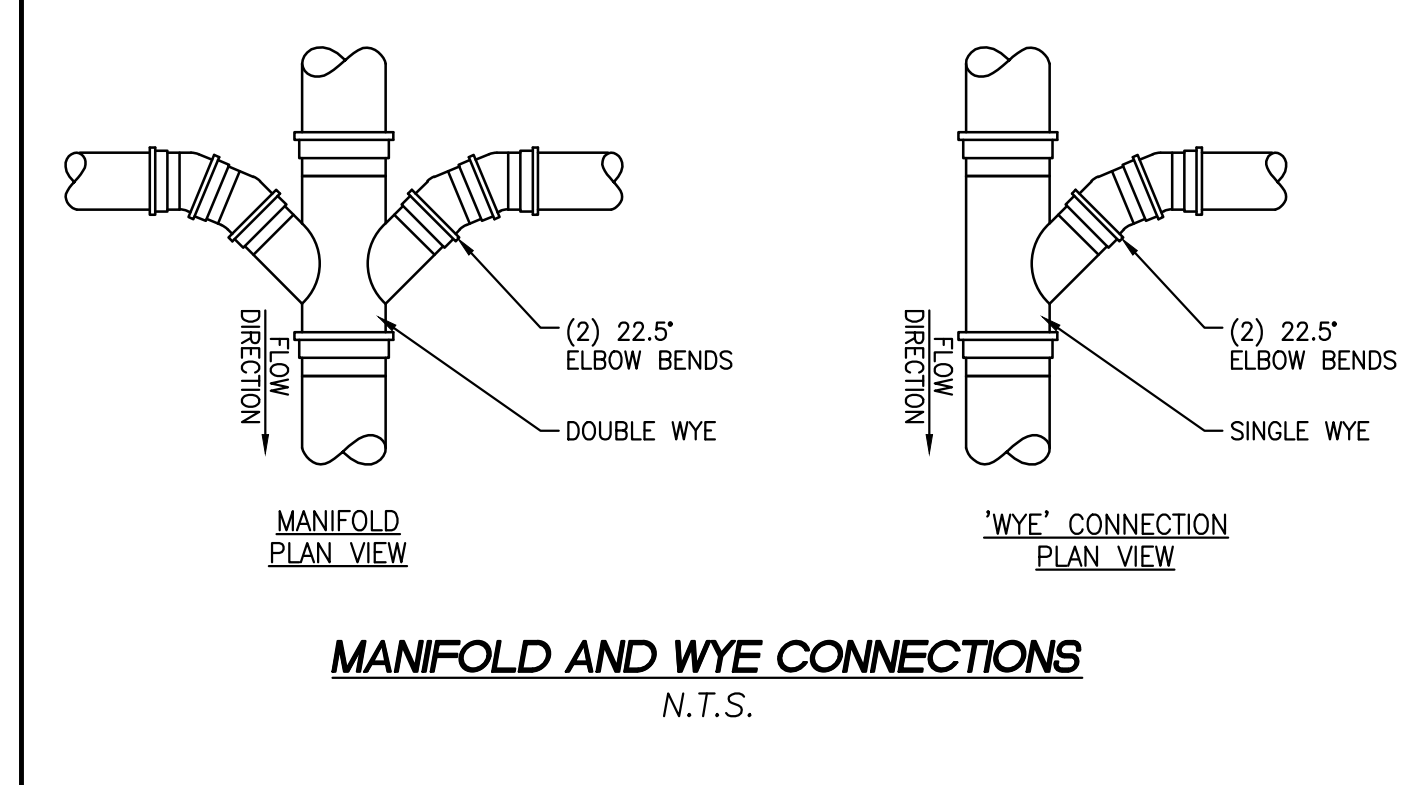
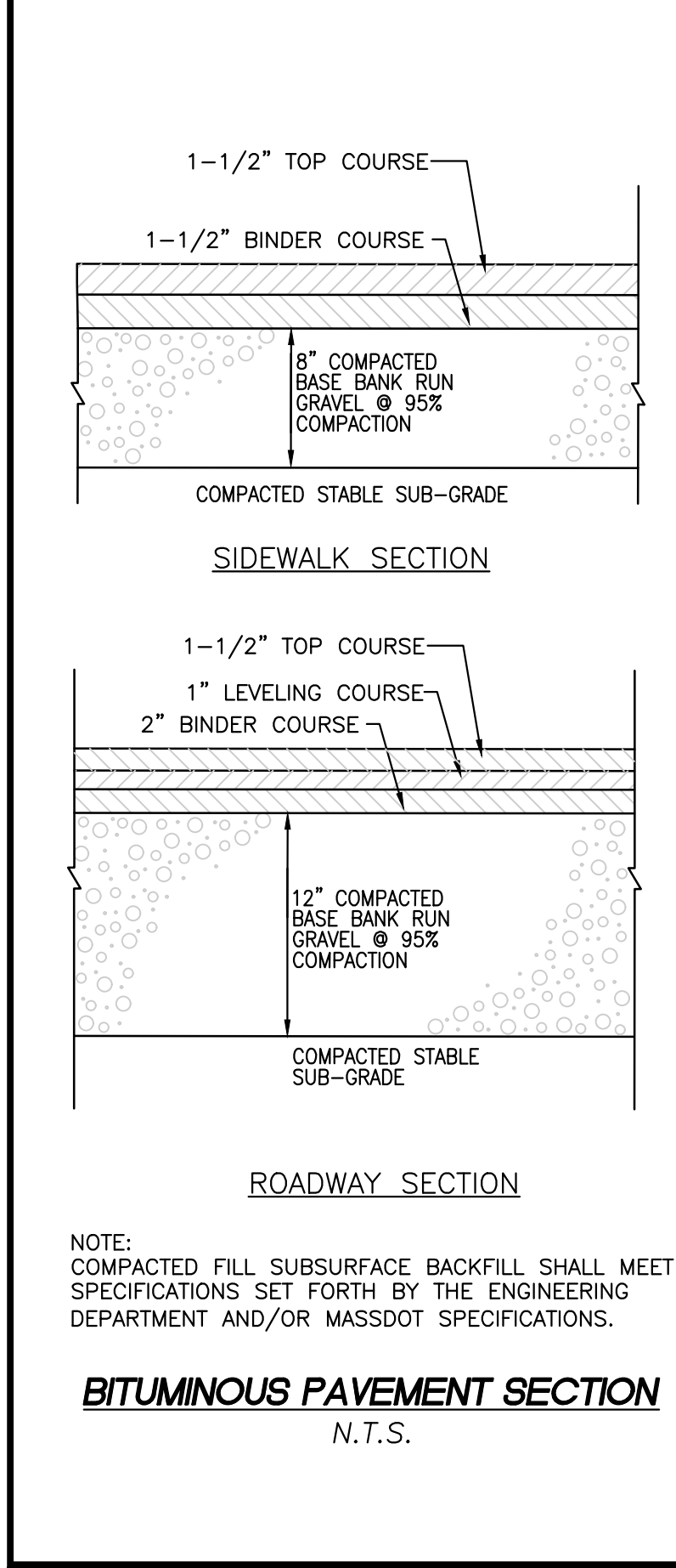
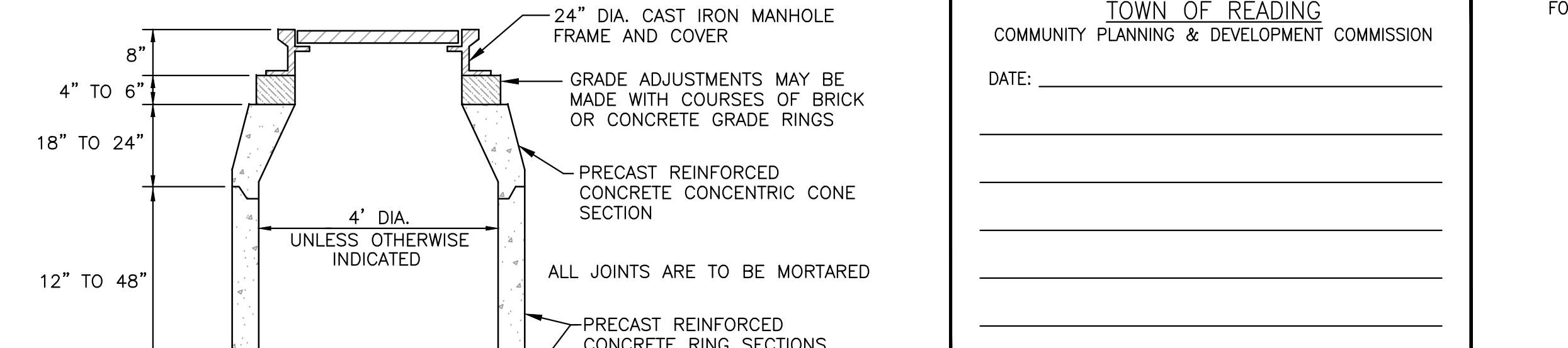
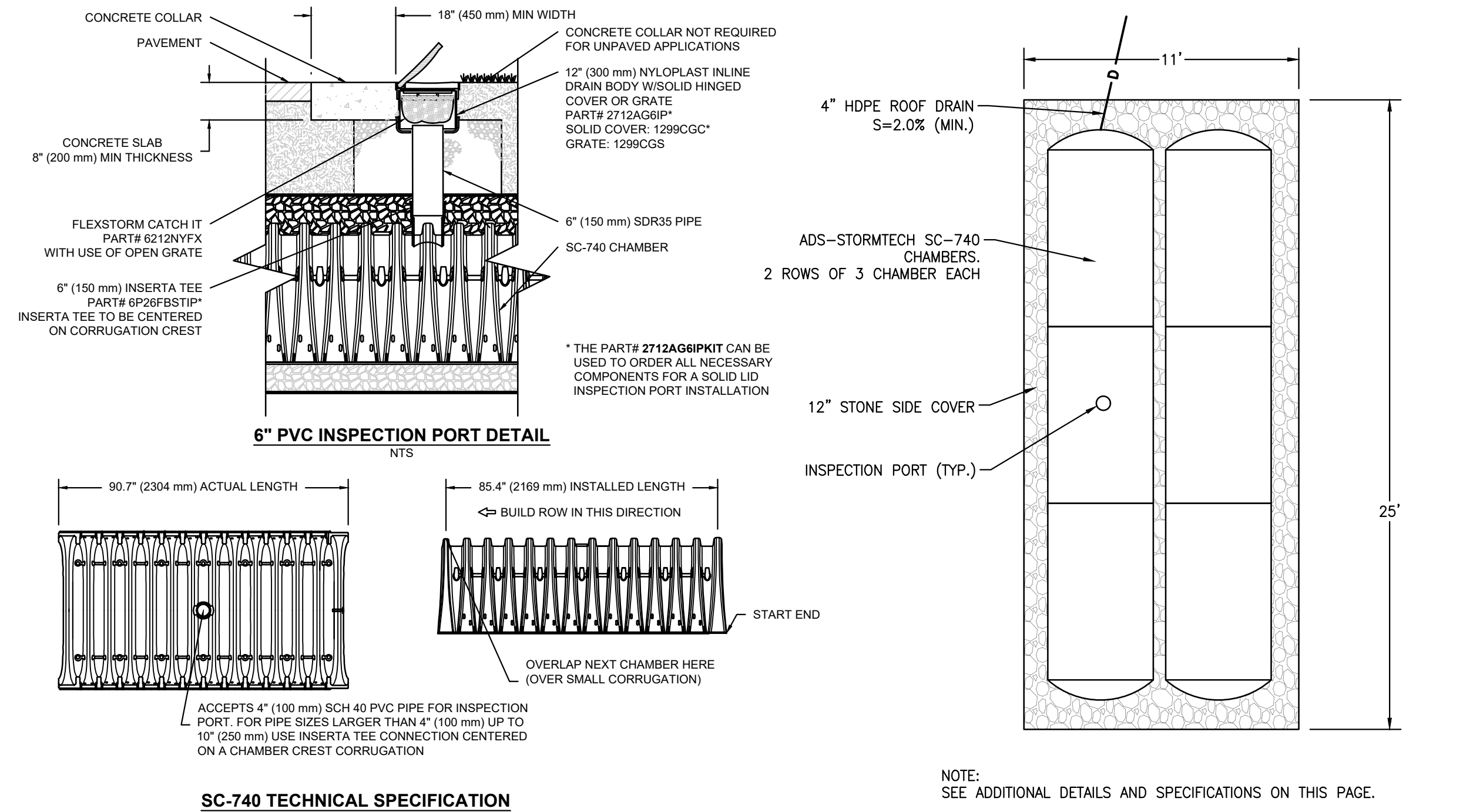

REVISION	DATE	BY

**PROJECT LOCATION:**  
LOTS 2, 3, & 4  
GRANDVIEW ROAD  
READING, MA 01867

**PARCEL ID:**  
MAP 27, LOT 404

**PLAN SET:**  
MAJOR SITE PLAN MODIFICATION  
GRANDVIEW ROAD SUBDIVISION - PRIVATE WAY  
(GRANDVIEW ROAD EXTENSION)

**SITE PLAN PERMIT SET**

APRIL 20, 2023

SCALE: N.T.S.

**TOWN OF READING**  
COMMUNITY PLANNING & DEVELOPMENT COMMISSION

DATE: \_\_\_\_\_

**ENGINEER:**  
**FODERA ENGINEERING**  
(617)877-3293  
gfodera@foderaengineering.com  
28 Harbor St., Suite 204  
Danvers, MA 01923

**SURVEYOR:**  
**PFS Land Surveying, Inc.**  
30 Balch Avenue  
Groveland, MA 01834  
P.978.891.5203  
www.pfsland.com

**PROFESSIONAL SEAL**  
GIOVANNI GAETANO FODERA  
No. 54884  
REGISTERED PROFESSIONAL ENGINEER

**PROFESSIONAL SEAL**  
Giovanni Fodera

**COPYRIGHT NOTICE:**  
This drawing is property of Fodera Engineering and is not to be used for any purpose other than the specific project and site named herein, and cannot be reproduced in any manner without the express written permission from the engineer on record.

**JOB NO.:** 20160-149

**SHEET TITLE:**  
DETAILS  
SHEET 2

**SHEET NUMBER:**  
C-7



# Memo

**To:** Andrew MacNichol, Community Development Director  
**From:** Alex Rozycki, P.E., Senior Civil Engineer  
**CC:** Ryan A. Percival, P.E., Town Engineer; Mary Benedetto, Senior Planner  
**Date:** April 27, 2023  
**Re:** Grandview Road Extension

---

Materials reviewed:

- Proposed Site Plans entitled; "Major Site Plan Modification- Grandview Road Subdivision prepared by Fodera Engineering dated April 20<sup>th</sup> 2023"
- Site Plan Set entitled "Penny Lane Subdivision – Grandview Road Extension – Private Way; prepared by Fodera Engineering; dated December 2nd 2020"

The Engineering Division has reviewed the proposed site application for the proposed project and offers the following comments:

- Previous plans for the southernmost home included roof drainage tied into the infiltration system, there are concerns that the adjacent property will now receive stormwater flows given the grades. The stormwater report indicates all impervious area will be captured, does that include hardscapes on the lots? The previous plan captured impervious areas on individual lots.
- The infiltration chamber design under the endorsed plans will allow for more land use in the backyard areas, the proposed detention pond design eliminates the use of land.
- Engineering sees no reason to support the waiver allowing less cover on utilities, there appears to be no benefit to support such a waiver.
- The Engineering Department does not approve of gas lines or electrical services, those shall be coordinated and approved by others.
- There are many instances of utilities crossing, we are particularly concerned with the crossing of water and sewer. Crossings should be limited, and invert elevations of the services may be requested to ensure proper separation.
- Inverts of the existing sewer manhole should be provided, as well as a detail for the force main connection.
- MaDEP regulations may not allow for discharge of water or overflow rip-rap within 10 feet of a property line.
- NPDES MS4 permit requirements shall be met for TSS removal and Phosphorous reduction. The supporting calculations should be provided and reviewed by Engineering. The project will also require a Storm Water Pollution Prevention Plan as well as an O&M plan for the proposed detention basin.
- A Sewer Connection I/I fee is required.
- The driveway curb cuts shall meet Town of Reading standard cross sections. The proposed elevations are unclear in these areas, all driveways will be approved individually.
- All utilities shall be approved materials and installed in accordance with the Department of Public Works Standards.
- Engineering Division shall be notified 72 hours in advance to mark out Town utilities.
- All water, sewer, curb cut, street opening and Jackie's Law excavation permits shall be obtained at the Engineering Division prior to any excavations.
- All site work shall be inspected by the Engineering Division. The Applicant/Owner's contractor shall submit a construction schedule of proposed work. All inspections shall be scheduled 48 hours in advance.
- An approved site as-built shall be submitted to the Engineering Division within 60 days of certificate of occupancy. The as-built shall be submitted in mylar and electronic ACAD format.

**FODERA**  
**ENGINEERING**  
28 Harbor Street, Suite 204  
Danvers, MA 01923  
Tel: (617) 992-8492  
contact@foderaengineering.com

March 10, 2023

**To:** Andrew MacNichol, Community Development Director  
Town of Reading  
Community Planning and Development Commission  
16 Lowell Street  
Reading, MA 01867

**RE: GRANDVIEW ROAD SUBDIVISION  
SITE PLAN MODIFICATIONS  
4 COLD SPRING ROAD  
READING, MA 01867**

To Mr. MacNichol,

The project at 4 Cold Spring Road known as Grandview Road Subdivision was approved by the Community Planning and Development Commission (CPDC) and a Decision of Approval was issued and dated February 8, 2021. The approved plans were endorsed and recorded at the Middlesex South District Registry of Deeds (M.S.D.R.D.) as Plan 754 of 2022. A deed for the subdivision was recorded as Book 80930 Page 320.

The site has since been revisited and site design changes have been made. The following is a summary of the revisions.

- Lot 2 will remain undeveloped but with the potential to be developed in the future.
- Lot 1 will keep the existing on-site shed and an associated easement into Lot 2 has been created for the encroachment.
- Relocated electric easement on Lot 2.
- The stormwater subsurface infiltration system has been replaced with a detention/infiltration basin and revised the drainage easement accordingly.
- The roadway has been regraded to create a low point at the end of the cul-de-sac.
- The building footprints for Lots 3 and 4 have increased from 1,925 sq-ft to 2,200.
- Created a larger backyard for Lot 4.
- Associated stormwater runoff calculations have been revised and the stormwater report has been updated.

Proposed stormwater pipes have reduced to just two (2) pipes and are at the end of the roadway, directed into the proposed infiltration basin. Cover above the pipes are approximately 2.5 feet, which will require a waiver from Section 7.4.4.3.e of the Subdivision Rules and Regulations dated August 26, 2006. The waiver is to accept a 2.5' cover above the drain pipes, which is less than the required four (4) feet and three (3) in vehicular roadways and easements, respectively.

Please accept this submittal as formal request for review. Please do not hesitate to call or email me shall you have any questions, comments, or concerns.

Sincerely yours,



---

Giovanni Fodera, P.E.

*Principal Engineer*

**FODERA Engineering**

Attachments:

- Major Site Plan Modification – Grandview Road Subdivision, dated March 10, 2023.
- Stormwater Management Report, Major Site Plan Modification, dated March 10, 2023.
- M.S.D.R.D. Plan 754 of 2022
- M.S.D.R.D. Book 80930, Page 320.

Cc: Michael Salamone  
Frank Lanzillo

A2



Bk: 80930 Pg: 320 Doc: DEED  
Page: 1 of 2 11/09/2022 03:01 PM

### Quitclaim Deed

**PENNY A. JEAN**, a single woman, of 4 Cold Spring Road, Reading, Massachusetts, for nominal consideration of Ten dollars (\$10.00), grant to:

**GRANDVIEW, LLC**, a Massachusetts limited liability company, of 45 Beacon Street, Reading, Massachusetts

With ***QUITCLAIM COVENANTS***

The land in Reading, Middlesex County, Massachusetts identified as Lots 2, 3 and 4, together with the fee in the land shown as "Grandview Road", as shown on a Subdivision Plan entitled "*Grandview Road Subdivision – Private Way, Grand View Road Extension*" prepared by Fodera Engineering, 28 Harbor Street, Suite 204, Danvers, MA 010923, dated December 3, 2020, revised through July 12, 2021, and which Plan is recorded herewith. Said land is conveyed subject to and with the benefit of all easements, agreement, covenants, and provisions of record. No right, title or interest is conveyed in, to or over the property shown as Lot 1 on said Plan, which is retained by the Grantor.

Grantor hereby releases and terminates any and all claims of homestead in the premises conveyed hereby, and further hereby state that no other person is entitled to claim the benefit of an existing state of homestead in the premises conveyed hereby.

Meaning and intending to convey a portion of the land conveyed to the Grantor by deed dated May 2, 2007, and recorded in the Middlesex County Registry of Deeds at Book 49389, Page 45.

Property Address: Lots 2, 3 and 4 and Grandview Road Extension, Reading, Massachusetts 01867

Executed as a sealed instrument this 25<sup>TH</sup> day of OCTOBER 2022.

Penny A Jean  
Penny A. Jean

Commonwealth of Massachusetts

Middlesex, ss.

On 25<sup>TH</sup> day of October, 2022, before me, the undersigned notary public, personally appeared Penny A Jean, the above-named and proved to me through satisfactory evidence of identification being PERSONAL KNOWLEDGE, to be the persons whose names are signed on this document, and acknowledged to me that she signed it voluntarily for its stated purpose and that the foregoing instrument is her free act and deed.

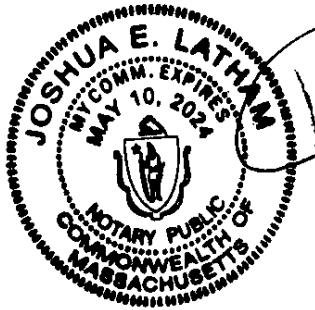

[Signature]  
Notary Public: JOSHUA E. LATHAM  
My Commission Expires: 5/10/24

SEE PLANS 754 OF 2022



REVISION	DATE	BY
REVISION 1	12/29/23	GFJ
CONSERVATION	2/17/23	GFJ
ENFORCEMENT SET	7/19/23	GFJ

PROJECT LOCATION:  
 4 COLD SPRING RD  
 READING, MA 01867

DRAWN BY:  
 MAP 27, LOT #04

PROJECT: GRANDVIEW ROAD SUBDIVISION - PRIVATE WAY (GRAND VIEW ROAD EXTENSION)

DATE: FEBRUARY 9, 2020

ENDORSEMENT SET

SCALE: 1" = 20'

**RIGHT-OF-WAY STATEMENT**  
 THE PROPOSED RIGHT-OF-WAY FRONT SOUTH OF THE INTERSECTION FROM COLD SPRING ROAD AND GRANDVIEW ROAD, IS PROPOSED AS A PRIVATE WAY FOR ALL LAND OWNERS N AND ABUTTING THE SUBDIVISION, AND WILL BE SHOWN IN WAYS AS SHOWN ON ROAD.

**LEGEND**

- PROPERTY LINE
- EASEMENT LINE
- WETLAND BOUNDARY
- RANGE MEASUREMENT
- WETLAND FLAG
- STONE BOUND WITH DRILL HOLE

**GENERAL NOTES**

- WETLANDS WERE FLAGGED BY LEG ENVIRONMENTAL CONSULTANTS IN JUNE 2020.
- THE PROJECT IS LOCATED OUTSIDE OF ANY PROTECTED RESOURCE AREAS AND FLOOD ZONES AS DETERMINED BY THE MOST RECENTLY PUBLISHED DATA FROM THE MASSACHUSETTS DEPARTMENT OF ENVIRONMENTAL PROTECTION AND FEMA.
- IN USE OF A RETAINING WALL LOCATED IN THE RIGHT-OF-WAY ALONG THE WESTERN BOUNDARY OF GRANDVIEW ROAD, A TEMPORARY 20' FEET WIDE SLOPE EASEMENT IS PROPOSED ON TOWN PROPERTY AND SHALL BE APPROVED BY THE TOWN. SEE SHEET C-5 FOR GRADING.

**PLAN REFERENCES**

- BOUNDARY, TOPOGRAPHIC, AND PLANNING INFORMATION WAS OBTAINED FROM AN ON-THE-GROUND SURVEY PERFORMED AND COMPLETED BY PFS LAND SURVEYING.

**PROPERTY INFORMATION**

ADDRESS: 4 COLD SPRING ROAD READING, MA 01867  
 MAP 27, LOT 004  
 1/4 MAP LOT: 75,400 S.F. (1.73 AC.)  
 LOT SIZE:

**RECORD OWNERS**  
 4 COLD SPRING ROAD  
 PENNY A. JEAN  
 4 COLD SPRING RD.  
 READING, MA 01867

**APPLICANT**  
 MICHAEL SALAMONE  
 45 SEACON ST.  
 READING, MA 01867

**ZONING SUMMARY**  
 ZONING DISTRICT: SINGLE FAMILY 1D (S10)

	REQUIRED	LOT 1	LOT 2	LOT 3	LOT 4
MIN. LOT WIDTH	60'	>60'	>60'	>60'	>60'
MIN. LOT AREA (SF)	15,000	22,112	15,000	15,000	15,104
MIN. FRONTAGE	100'	132.00	151.62	100.00	100.00
RELIEF REQUIRED	-	N	N	N	N

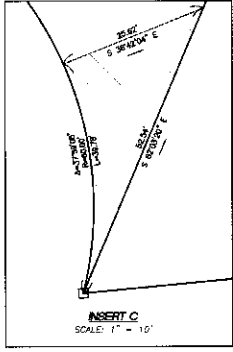
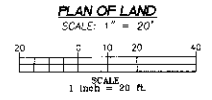
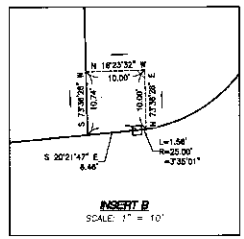
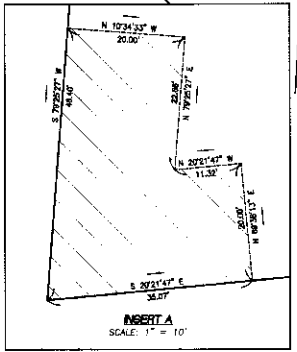
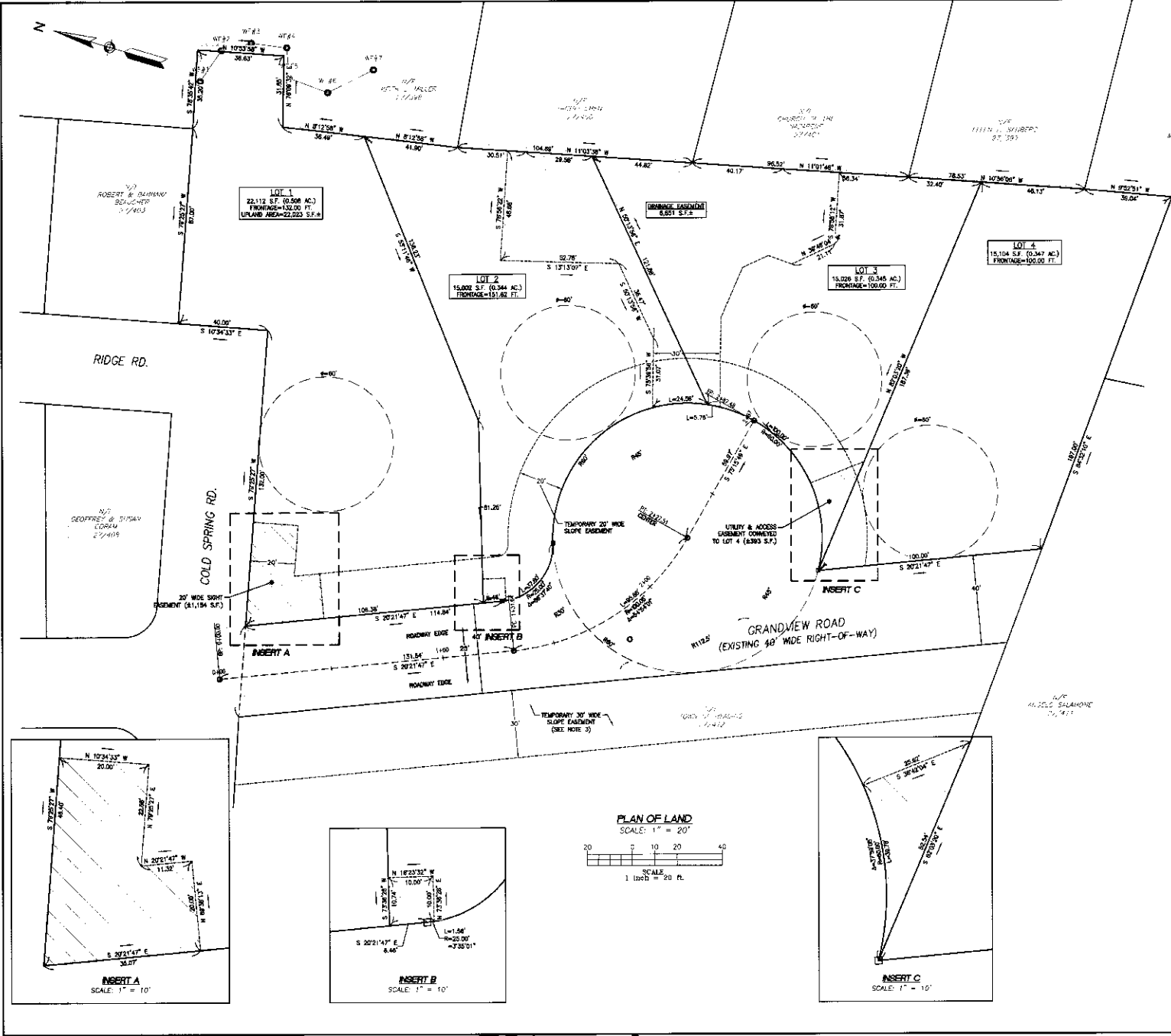

754 of 2022

**TOWN OF READING**  
 COMMUNITY PLANNING & DEVELOPMENT COMMISSION

DATE: *[Signature]*

FOR REGISTRY USE ONLY  
 Approver: Registry of Deeds,  
 Southern District  
 Commonwealth of Massachusetts  
 Plan No. 754 of 2022  
 Rec'd 11-9 2023  
 ST. H. Y. M. P. M.

Attest: *[Signature]*  
 Registrar

**ENGINEER:**  
**FODERA ENGINEERING**

**SURVEYOR:**  
**PFS Land Surveying, Inc.**

187.877-2293  
 pfsland@pfslandsurveying.com  
 24 Fuller St., Suite 204  
 Danvers, MA 01923

PROFESSIONAL SEAL  
 GEORGE SALAMONE  
 No. 44884  
 State of Massachusetts

PROFESSIONAL SEAL  
 MICHAEL SALAMONE  
 No. 44884  
 State of Massachusetts

**JOB NO.:** 20160-145  
**SHEET TITLE:** PLAN OF LAND  
**SHEET NUMBER:** C-1

## Memorandum

May 10, 2023

To: Andrew MacNichol, Community Development Director  
Town of Reading  
Community Planning and Development Commission  
16 Lowell Street  
Reading, MA 01867

RE: Grandview Road Subdivision

The Conservation Commission reviewed the March 10<sup>th</sup> 2023 memo by Fodera Engineering regarding site design changes. Although, the Conservation Commission supports stormwater infiltration systems. This change would require the applicant to return to the conservation commission for review and approval.

- The stormwater subsurface infiltration system has been replaced with a detention/infiltration basin

Sincerely,

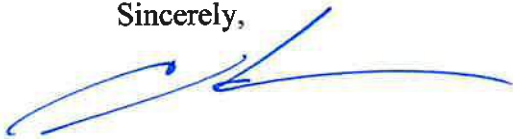

Chuck Tirone  
Conservation Administrator

**FODERA**  
ENGINEERING  
28 Harbor Street, Suite 204  
Danvers, MA 01923  
Tel: (617) 992-8492  
contact@foderaengineering.com

June 7, 2023

To: Mary Benedetto, Senior Planner  
Town of Reading  
Community Planning and Development Commission  
16 Lowell Street  
Reading, MA 01867

**RE: GRANDVIEW ROAD SUBDIVISION  
EXTENSION REQUEST  
4 COLD SPRING ROAD  
READING, MA 01867**

To Ms. Benedetto,

The project at 4 Cold Spring Road known as Grandview Road Subdivision is a four-lot residential subdivision. The existing lot identified as parcel ID: 27-404 has an existing dwelling structure on site. The project is to divide the land to create three (3) new single-family lots, and the existing dwelling will remain. The project was approved in 2021 and the approved plans were endorsed by the Community Planning and Development Commission (CPDC) on 7/12/2021.

Per Section 9.4.1 of the local Subdivision Regulations, the time limit for completion is two years from endorsement or date in surety, whichever is sooner. In this case, the endorsement date would control and therefore the time limit would end on 7/12/2023.

We are requesting a one-year extension for the Time Limit for Completion. Work did not commence for the project due to fine tuning agreements between the landowner and applicant. The landowner decided to retain the newly created parcel (Lot 2) behind her existing dwelling lot. The new agreement between the applicant and landowner had to be created and took time to finalize between both parties. Additionally, delays from COVID-19 further slowed the process. We ask that this letter be a formal request for extension.

Sincerely yours,



---

Giovanni Fodera, P.E.  
*Principal Engineer*  
**FODERA Engineering**





**Town of Reading**  
**16 Lowell Street**  
**Reading, MA 01867**

**Andrew MacNichol**  
**Community Development**  
Phone: 781.942-6670  
Fax: 781.942-9071  
Website: [www.readingma.gov](http://www.readingma.gov)

---

**July 10, 2023**

## **Site Plan Review DECISION**

Project: 25 Haven St, Place of worship/youth center  
Applicant: North American Foundation of Islamic Services (NAFIS)

*To the Town Clerk:*

*This is to certify that, at a public hearing of the Community Planning and Development Commission opened on July 10, 2023 and closed on July 10, 2023 by a motion duly made and seconded, it was voted:*

“We, the Reading Community Planning and Development Commission, upon request from NAFIS, under the provision of Sections 4.3 and 4.6 of the Zoning Bylaws of the Town of Reading, and MGL Chapter 40A, Section 3, to consider the proposed site plan for 25 Haven St (Assessors Map 16, Lot 309) – as shown on the Site Development Plans and architectural elevations prepared by Farouk F. Youssef, dated May 31, 2023 - do hereby vote **XXX, to \_\_\_\_\_ the said plans**, subject to the Findings and Conditions below.”

Materials Submitted:

The following materials were submitted into the public record:

- a) Site Plan Review Application and Project Narrative, received 6/13/23.
- b) Certified List of Abutters, dated 6/14/23.
- c) Legal Notice published in the Daily Times Chronicle on 6/26/23 and 7/3/23.
- d) Proposed Site Plan Set, for mosque at 25 Haven St, Reading, MA, prepared by Hayes Engineering Inc., including the following:
  - a. Sheet C1: Index Plan, dated 5/25/23
  - b. Sheet C2: Site Plan, dated 5/25/23
  - c. Sheet C8: Detail Sheet, dated 5/22/23
- e) Floor Plans & Exterior Elevations, prepared by Farouk F. Youssef, including the following:
  - a. Sheet A-3: Existing 1<sup>st</sup> Floor Plan, dated 5/31/23
  - b. Sheet A-4: Existing East & North Elevations, dated 5/31/23
  - c. Sheet A-5: Existing West & South Elevations, dated 5/31/23
  - d. Sheet A-6: Proposed 1<sup>st</sup> Floor Plan, dated 5/31/23
  - e. Sheet A-7: Proposed 2<sup>nd</sup> & 3<sup>rd</sup> Floor Plans, dated 5/31/23

- f. Sheet A-8: Proposed East & North Elevations, dated 5/31/23
- g. Sheet A-9: Proposed West & South Elevations, dated 5/31/23
- f) Stormwater Management Report for Proposed Mosque at 25 Haven St, prepared by Hayes Engineering Inc., dated 5/22/23
- g) Draft Decision, dated 7/10/23.

**Findings:**

- 1) Overview: The subject site is a 0.43-acre lot entirely within the Business-B (BUS-B) Zoning District. The land totals 18,935 square feet in area and maintains ~186.78 linear feet of frontage along Haven Street to the north and ~119.51 linear feet of frontage along Green Street to the south. The site is abutted by: Haven Street to the north; both a single-family dwelling and a one-story commercial building to the east; Green Street to the south, and; a two-story commercial building to the west.

The Applicant proposes to redevelop the 25 Haven St site into a three story, ~23,000sf Mosque and educational center. The existing single-story structure is to be improved with new masonry and window treatment. The stories above shall consist of masonry, clapboard siding and window treatment.

- 2) Existing Site: The existing site maintains a vacant ~7,953 square-foot, single-story commercial structure and associated parking. It maintains one curb cut along Haven Street and another curb cut along Green Street.
- 3) Zoning: The site is located within the underlying Business-B Zoning District and the Downtown Smart Growth District (DSGD) / 40R Overlay District. Sites and areas located to the north, south, east and west are also located in the Business-B and DSGD Zoning Districts.
- 4) Site Plan Review Applicability: According to Section 4.6.2 of the Zoning Bylaw,
 

*“Site Plan Review is required if the proposed construction or site alteration involves any of the following:*

  - a. *An increase in Gross Floor Area of 500 square feet or more, via the creation of new floor area, that results in the requirement for or addition of 2 or more parking spaces (regardless of parking-related exemptions or waivers); or*

The project triggers Site Plan Review by an Increase in Gross Floor Area greater than 500sf.

- 5) Religious Use: The use of this site as a religious use is protected under the Dover Amendment, G.L. c. 40A, §3. Chapter 40A, §3 states the land and structure may be subject to “reasonable regulations concerning the bulk and height of structures and determining yard sizes, lot area, setbacks, open space, parking, and building coverage requirements.”
- 6) Historic: The existing building is listed on the local Reading Historical Inventory and would be subject to a demolition delay if the existing building were to be completely demolished. The proposed design reuses the existing one-story building as the base of the 3-story building and as such is not subject to any delay.

- 7) Setbacks and Dimensional Requirements: The lot maintains frontage on both Haven & Green streets, and thus interpreted to have two front-yards and two side-yards.
- a. The building has a front-yard setback of 0-foot from the northern lot line (Haven Street) where 0-feet is required, totaling 77-feet in length; a 0-foot front-yard setback from the southern lot line (Green Street), totaling 66-feet in length; a 1-foot side-yard setback from the western lot line where 30' is required, totaling 79-feet in length; and, a varying side-yard setback, greater than 30-feet, from the eastern lot line, totaling 128-feet in length. There is a 14' x 17.5' bump-out in the southwest corner of the site. As none of the existing setbacks are proposed to be altered in the new building design and the general building layout remains the same, it is appropriate, consistent with G.L. c. 40A, § 3, to permit the applicant to maintain the existing side-yard setback which is less than the required 30' pursuant to Section 6.3 of the Zoning Bylaw.
  - b. Allowable building height in the Bus-B district for a religious use is 45 ft and the proposed building height is 40 ft.
- 8) Interior Space: The proposed first floor includes two lobby entrances and an additional exit, the new elevator, a 725sf social area, a 5,600sf prayer area, a 300sf office for the Imam, a 275sf conference room, associated storage and utility space, and updated men's and women's restrooms. The second and third floors are currently proposed as open social space with storage and men's and women's restrooms. Other future uses and more detailed build-outs for the second and third floors are to be determined.
- 9) Site Access and Circulation: The building will maintain three points of egress. The parking lot will maintain its existing one-way circulation with cars entering on Haven St and exiting on Green St (right turn only).
- 10) Parking and Loading: The revised parking design for the lot includes 26 total spaces. Of the 26 total spaces 18 are standard 9' x 18' spaces, 2 are 8' x 18' ADA spaces, and 6 are 8' x 14' compact spaces.
- a. The proposed square footage of the building would require 1 parking space for every 300 square feet proposed, meaning 77 parking spaces should be required. However, section 9.1.1.1 of the Zoning Bylaw provides that retail stores, offices, and consumer service establishments within three hundred feet of an off-street public parking facility shall be exempted from off-street parking requirements. The proposed religious use is subject to reasonable parking requirements under G.L. c. 40A, § 3. Because the proposed use is substantially similar to retail stores, offices, and consumer service establishments and the site is within 300 feet of the public Brande Court parking lot, it is appropriate to extend the off-street parking requirement exemption to the proposed use.
- 11) Traffic: Hours of operation for the site will be mostly weekday evenings from 7-9pm, weekends from 10am-2pm and 7-9pm, Fridays from 1-2pm. For Friday gatherings the use anticipates 80-100 people attending services, many of them travelling together.

- 12) Utilities: Water, sewer, gas and electric/telephone/communication connections will be maintained and upgraded as needed. All utilities and connections shall be installed per the requirements of the Engineering, DPW and RMLD Departments.
- 13) Drainage/Stormwater: The project as proposed will not create any new untreated discharges of stormwater runoff. Stormwater runoff from the roof system is proposed to go through a subsurface infiltration system, improving TSS removal rates over the existing conditions. Parking lot grading is to mimic existing conditions. Post-development peak discharge rates do not exceed pre-development rates.
- 14) Landscaping: The site is currently almost entirely impervious surface. The proposed changes to the lot will result in an increase in impervious surface area by 1,309sf—in order to increase the available parking spaces in the lot. Existing trees will be maintained where possible and new landscaping of loam and seed will be placed in the new landscaped beds located along the site driveways.
- 15) Lighting: Existing lighting is proposed to be used wherever possible, any new lighting will be reviewed by staff for approval. Building and parking lot lighting is to be Dark Sky compliant.
- 16) Conservation: There are no resource areas within the 25 Haven St site.
- 17) Signage: No signage has been approved herein. Any future signage shall require the submittal of a Sign Permit Application and shall comply with Section 8.0 of the Zoning Bylaw.
- 18) Dumpster & Trash Management: No exterior dumpster enclosure proposed. Trash removal is to be handled by third party contractor.
- 19) Snow Storage and Removal: Snow shall be stored in a manner so that it shall not impact the landscaping, vehicular sight lines, travel lanes or parking areas.

**Conditions:**

**General:**

- 1) **Public Health, Safety and Welfare**: If, at any time, the site becomes a nuisance to public health, safety or welfare (i.e., traffic spillover, excessive noise, unreasonable site illumination beyond the hours of operation, etc.) – as shall be evidenced by substantiated complaints to the Police Department or Public Services Office – the Applicant/Owner shall agree to work with PTTTF Staff to rectify the problem. Should the situation warrant it, an additional Site Plan Review by the CPDC may be required.
- 2) **Utilities**: All utilities, structures, frames and covers shall meet the Town of Reading standards. The electric utility plan is subject to approval by the Reading Municipal Light Department (RMLD).
- 3) **Site Plan Decision**: The Site Plan Decision herein does not include approval for any future uses or site renovations that may – on their own merits and design – trigger the requirements of site plan review and/or require a special permit. All future proposed uses requiring a site plan review or a special permit shall obtain such approval(s) prior to occupancy of any tenant space.

- 4) **Sidewalk Improvement:** The Applicant shall seek permission to repair and improve any damage to the sidewalk along their property frontage in compliance with the Engineering Division requirements as deemed necessary or advantageous.
- 5) **Handicap Parking:** The handicap parking spaces shall be properly posted in the locations depicted on the approved Plans.
- 6) **Landscaping:** The landscaping shall be installed as indicated on the final approved plans. In the event that weather conditions prevent completion of the proposed landscaping prior to the desired date of occupancy, the Applicant shall submit a bond to cover the cost of installation of the remaining landscaping features.
- 7) **Architecture:** The building façade on each elevation (north, south, east, west) shall be substantially as indicated on the approved architectural plans and elevations.

#### **Prior to the Commencement of Site Work and Issuance of Building Permit:**

- 8) **Engineering Concerns:** The Applicant shall work with Engineering staff to satisfy requirements for drainage and infiltration.
- 9) **Structural:** A structural engineer shall provide needed information and assurance to confirm the existing building can support the additional building levels.
- 10) **Demolition:** Should it be determined that the existing building is to be demolished and replaced the Applicant shall provide a Demolition Permit Application and exercise the requirements under Reading General Bylaw Section 7.2 Historic Demolition Delay.
- 11) **Utility:** The Applicant shall work with the Engineering, DPW, RMLD and other utility providers to satisfy requirements of the respective departments.
- 12) **Plan Revisions:** The Applicant shall revise the Site Plan pursuant to any conditions imposed herein and submit 2 full-size (24x36) copies of the revised plans to the Community Development Director for review and approval prior to the issuance of a Building Permit.
- 13) **Other Permits:** The Owner/Applicant is responsible for obtaining all other requirements and permits including but not limited to, utility connections, sewer, water, curb cut, street opening and Jackie's Law excavation permits from the Engineering Department (prior to excavation), and Board of Health approvals.
- 14) **Pre-construction Meeting:** The Owner/Applicant and contractors shall coordinate with the Community Development Director to schedule a pre-construction meeting with Town staff prior to applying for building permits, in order to review these conditions and any and all final construction sequencing, details and plans for this project.
- 15) **Stormwater:** TSS and Phosphorous Removal calculations shall be submitted. A Stormwater Operation and Maintenance Plan shall be submitted for review and approval by the Engineering Department prior to the start of construction. The Plan shall be developed for construction and post construction procedures and shall be provided in a report separate from the construction plans.
- 16) **Construction Schedule:** A construction schedule shall be submitted to the Community Development Director, Town Engineer, Conservation Commission and Building Inspector prior to the start of construction.

- 17) **Construction Drawings:** Full construction documents must be submitted and approved by the Fire Department. A building permit shall not be issued until the Fire Department has approved the plans.

**During Construction:**

- 18) **Construction Hours:** Construction shall be limited to the hours stated in Section 8.9.8 “Construction Hours” of the Reading General Bylaws and said hours shall be posted in a conspicuous place at the entrance prior to any work on the site.
- 19) **Construction Activities:** Construction activities shall be conducted in a workmanlike manner at all times. Blowing dust or debris shall be controlled by the Applicant through stabilization, wetting down, and proper storage and disposal methods, subject to the approval of the Health Agent or designee. The Applicant shall ensure that the abutting local streets are kept clear of dirt and debris, which may accumulate as a result of construction activities for the Project. Documentation shall be provided demonstrating ongoing pest management control, subject to the approval of and administration by the Health Division.
- 20) **Site Inspections:** Town staff or their designee shall have reasonable access to inspect the site to determine compliance with this Decision.
- 21) **Coordination with Town Officials:** The Applicant and/or its contractor shall provide – during construction – complete, full coordination with local officials on making alterations to existing utilities, future utilities on site shall be installed underground, subject to local utility approval.
- 22) **Plan Changes:** Any changes to the site layout or utility design during site work or construction shall be submitted to the Engineering Division and Community Development Director for review and approval prior to the construction of the change in design.
- 23) **Bond:** The Applicant/Owner shall furnish a bond for the final As-Built plans prior to the issuance of the final certificate of occupancy. The bond amount shall be determined by the Town Engineer. The bond shall be returned once the requirements of this condition are met.

**Prior to the Issuance of Occupancy Permit:**

- 24) **Compliance Review:** The Applicant shall schedule a meeting with the Building Inspector and Community Development Director to review compliance with this decision and any other applicable permits.
- 25) **Pavement Markings:** Pavement markings/arrows within the site shall be painted as they are shown on the plan.
- 26) **Operation and Maintenance Plan:** An O&M Plan shall be prepared for the catch basins and stormwater management infrastructure.
- 27) **As-Built Plans:** Two full size paper copies and electronic AutoCAD final As-Built plans showing the building footprint, drainage systems and utility connections shall be submitted to the Community Development Director and Town Engineer to ensure compliance with this decision and other applicable Town standards. The bond held for this requirement will be returned to the Applicant once this condition has been fulfilled.
- 28) **Life Safety:** All life safety devices shall be in place and inspected for functionality.

### **Conditions for Ongoing Maintenance after Occupancy:**

- 29) **Sign Permit Application:** No signage has been approved herein. The Applicant shall file a sign permit application and request a Certificate of Appropriateness from the CPDC prior to signage installation.
- 30) **Landscaping:** The site landscaping as depicted on the approved plan shall be maintained in a healthy condition in perpetuity. In the event that landscaping is damaged during snow removal operations, the property owner shall replace such landscaping during the next growing season.
- 31) **Snow Removal:** Snow shall be stored in a manner so that it shall not impact the landscaping, vehicular sight lines, travel lanes or parking areas. Snow shall be removed from the site by the Applicant and/or its designee if the accumulated snow exceeds the capacity of the snow storage area or impedes vehicular sight lines, travel lanes or the parking lot.
- 32) **Trash Removal:** All trash collection and disposal are the responsibility of the future owner. The owner shall ensure daily that exterior areas of the site remain clear of debris, trash and any equipment used in connection with any commercial activities on site. Trash pick-up shall be contained on-site and shall not impede access into the site.
- 33) **Storm Water Operations & Maintenance:** Conditions within the long-term Operations and Maintenance Plan shall be adhered to by the Property Owner. Annual O&M reports shall be delivered to the Town Engineer by January 15<sup>th</sup> of each year.

### **Modifications/Revisions - Plan Changes after Approval by the Approving Authority:**

If, at any time before or during development, it becomes necessary or desirable for an Applicant to make modifications to a Site Plan, the Applicant shall appear at a regular meeting of the CPDC and submit, if required by the CPDC, plans showing the modification. Modification requests shall be processed in accordance with the rules governing Site Plan Review unless, upon review and determination by the Community Development Director, the proposed changes qualify as a Minor Modification pursuant to Section 4.6.9.2.

**1. Minor Modification:** Changes that do not substantially alter the concept of the approved Plan in terms of the specific location, the proposed land use, the design of building form and approved building details and materials, site grading or egress points. These include but are not limited to small changes in site layout, topography, architectural plans, landscaping plan, traffic circulation, parking, lighting, signage, open space or other criteria set forth in Section 4.6.9.1. Requests for approval under a minor modification for future renovations/alterations to the approved site plan or for future tenant changes shall be reviewed by the Community Development Director to determine if the proposed work qualifies for review through the Minor Site Plan Review process of Section 4.6.3 of the Reading Zoning Bylaw. If the work is eligible for review under Minor Site Plan review, the Community Development Director may review and grant approval of the proposed work by administrative approval of the Minor Modification. At the determination of the Community Development Director, the Applicant may be required to present the proposed project at a public meeting of the CPDC.

**2. Major Modification:** If, at any time before or during development, it becomes necessary or desirable for an Applicant to make modifications to a Site Plan, the Applicant shall appear at a regular meeting of the CPDC and submit, if required by the CPDC, plans showing the

modification. Modification requests shall be processed in accordance with the rules governing Site Plan Review unless, upon review and determination by the Community Development Director, the proposed changes qualify as a Minor Modification pursuant to Section 4.6.9.2. The following changes shall be deemed to qualify as a Major Modification: any relocation or shifting of structures or parking areas; any increase in the gross floor area of structures or any changes to the building envelope; any change that requires additional water or sewer usage or the relocation of water and sewer utilities; any increase in impervious areas, either by changes to structures or paved parking areas; or substantial changes to the approved architectural drawings, including changes in building materials and color.

*Signed as to the accuracy of the vote as reflected in the minutes*

---

Andrew MacNichol, Community Development Director

Date

*Cc: Applicant, Town Clerk, DRT Staff, planning file*





**Town of Reading**  
**16 Lowell Street**  
**Reading, MA 01867**

**Andrew MacNichol**  
**Community Development Director**  
Phone: 781.942-6670  
Fax: 781.942-9071  
Website: [www.readingma.gov](http://www.readingma.gov)

July 10, 2023

## Preliminary Subdivision Plan DECISION of APPROVAL

*246 Walnut St*

**Proposed Street Name: Walnut St Extension**

*To the Town Clerk:*

*This is to certify, that at a public hearing of the Reading Community Planning and Development Commission (CPDC), which was opened on July 10, 2023, and closed July 10, 2023, by a motion duly made and seconded, it was voted:*

“We, the CPDC, as requested by Stella Construction, under the Town of Reading’s Subdivision Rules & Regulations, and MGL Chapter 41 Sections 81K through 81GG, to consider the 3-Lot Preliminary Subdivision Plan for property located at 246 Walnut St (Assessors Map 3, Lot 19), as shown on the plans prepared by Meisner Brem Corporation, originally dated May 3, 2023, and most recently revised June 14, 2023, in support of an application filed on June 26, 2023, do hereby vote X-X-X to XXXX the said plans, inclusive of the waivers listed herein, subject to the Findings and Conditions below.”

### **MATERIALS:**

The following documents and plans were submitted into the public record:

1. Form B: Application for Subdivision Approval, filed with the Town Clerk 6/26/23.
2. List of Requested Waivers from Reading Subdivision Regulations, dated 7/6/23.
3. Certified List of Abutters, dated 6/14/23.
4. Email from Staff Planner to Applicant’s Engineer with a statement deeming the submission Substantially Complete, and including a list of minor revisions to be made for the next plan submission, dated 6/21/23.
5. Legal Notice, published in Daily Times Chronicle on 6/26/23 and 7/3/23.
6. Preliminary Subdivision Plan of Land for 246 Walnut St, Reading MA, prepared for: Stella Construction, prepared by: Meisner Brem Corporation, including the following:
  - a. Sheet 1 of 3: Cover Sheet and Location Plan, dated 5/3/23; and most recently revised 6/14/23
  - b. Sheet 2 of 3: Preliminary Subdivision Plan, dated 5/3/23; and most recently revised 6/14/23
  - c. Sheet 3 of 3: Preliminary Subdivision Layout Plan, dated 5/3/23; and most recently revised 6/14/23.
7. Draft Decision, dated 7/10/23.

## **FINDINGS:**

1. **Existing Conditions:** Walnut St is an existing 50' wide Public Way with 24' of paved roadway width serving eight single-family homes that dead-ends in a partial cul-de-sac. The development tract is comprised of 246 Walnut St, which is the last house on Walnut St. The 2.02-acre tract currently has one single-family home on the western portion of it, closest to Walnut St. The site is entirely within the S-20 Zoning District. The tract maintains 240 linear ft of frontage along Walnut St. The eastern portions of the site are flagged wetlands and the eastern abutting properties contain a river. The 100' inner riverfront line crosses approximately the eastern third of the tract and the 200' outer riverfront line covers the majority of the site, with only the westernmost portions excluded.
2. **General Proposal:** The Applicant is proposing to raze the existing single-family home and to subdivide the lot into three buildable tracts. Walnut St is proposed to be extended by approximately 270' in length, with a 50' right-of-way width on paper and 24' width paved. The applicant is requesting a waiver to reduce the right-of-way width from 60' to 50'. The extension will terminate in a cul-de-sac with a radius of 60', 40' of which will be paved.
3. **Zoning & Upland Area:** The site is within the S-20 Zoning District; of which three lots will comply with the frontage and area requirements of the S-20 Zoning District. It is anticipated that the proposed homes will comply with the dimensional and bulk requirements of the S-20 Zoning District. There are no known Special Permits or Variances relative to the subject properties  

A minimum total of 20,000sf of area, 12,000sf of upland area, and 120' linear feet of frontage is required. Or per Footnote 3, the required frontage can be reduced to not less than 80 ft if the street is a curve having a radius of not more than 200 ft and that lot has a width of not less than 120 ft.

  - a. Lot 1 is proposed to be 21,000sf, all of which is upland, with 410 ft of frontage.
  - b. Lot 2 is proposed to be 27,500sf with 13,500 upland and 100ft of frontage.
  - c. Lot 3 is proposed to be 26,500sf with 14,5000 upland and 270ft of frontage.
4. **Proof of Concept & Proposed Right-of-Way:** The proposed 50' right of way would extend the existing 50' right of way of Walnut St and terminate in cul-de-sac. The extension will provide the necessary frontage and access for the proposed 3 new single-family homes on the tract.
5. **Wetlands:** A wetland survey was performed by Basbanes and Associates in January 2023 and an area of Bordering Vegetated Wetlands (BVW) was flagged on the eastern portion of the tract. The buildable lot areas are proposed outside of the 35' no build zone, although work is proposed within the 100' buffer zone. The flagged bank of the river in the eastern abutting properties means that the 100' inner riverfront line crosses approximately the eastern third of the tract and the 200' outer riverfront line covers the majority of the site, with only the westernmost portions excluded.
6. **Conservation Review Restriction:** The Application will require a Notice of Intent with the Conservation Commission, and the issuance of an Order of Conditions. As part of the notice of intent the applicant will be required to perform an alternative analysis pursuant to 310 CMR 10.58(4)(c) for work in the outer riparian zone of the river front area.
7. **Traffic:** Due to the proposal of a single buildable tract with a net of three single-family dwellings, a waiver has been requested from providing a full Traffic Study.
8. **Trees/Landscaping/Screening:** Deciduous and Evergreen trees with 6" and greater diameter are to be depicted on a Definitive plan set. Area/count of tree removal, tree preservation and tree replacement are to be provided.

9. **Lighting:** No street lighting has been proposed and a waiver request has been provided for such. Typical house mounted lights will be provided at the proposed lot.
10. **Utilities:** Both Town water and sewer are proposed to be extended and connected to the proposed house lot. Electric, Telephone and Cable service shall also be provided. All utilities are proposed to be underground and extended through the proposed right-of-way. A new hydrant is proposed at the end of the cul-de-sac.
11. **Drainage:** Associated road runoff is expected to be directed to a stormwater infiltration system located on the eastern edge of the cul-de-sac between Lots 2 & 3.
12. **Easements:** There is proposed drainage easement on Lots 2 & 3 in conjunction with the proposed drainage system.
13. **Stormwater Permit:** A stormwater permit application will be required with a Definitive application. The Conservation Commission shall issue and oversee the Stormwater Permit.
14. **Rooftop Solar:** The Applicant shall consider orienting the homes so that future owners can benefit from potential rooftop solar installations and/or passive heating.

**WAIVERS:**

**The Applicant has requested, and the Commission has voted the following waivers from the Town of Reading Subdivision Regulations, with guidance:**

1. A waiver from Section 6.1.1.d.3 requiring a full traffic study.
  - a. *The Applicant requests relief from the requirement due to the modest scope of three additional single-family dwellings.*
2. A waiver from Section 7.1.1.a requiring a right of way width of 60-feet.
  - a. *The existing layout of Walnut St is 50-feet wide and the Applicant proposes to extend the layout of Walnut St at the 50-foot width, because of such the Applicant requests relief of this requirement.*
3. A waiver from Section 7.1.3 requiring Typical Cross Section for a Sixty-Foot Street.
  - a. *Due to the proposal of a 50-foot street the Applicant proposes a 24-foot paved travel way with no sidewalks.*
4. A waiver from Section 7.1.3.e requiring side slopes no steeper than three feet horizontal to one foot vertical (3:1)
  - a. *The Applicant proposes a slope of 2:1 to provide grading flexibility.*
5. A waiver from Section 7.1.5.a requiring dead end streets to be no longer than 500-feet.
  - a. *The Applicant proposes an extension of Walnut Street by 270-feet, bringing the dead end of Walnut Street to a total of XXX-feet in length. A 45-foot paved cul-de-sac is provided for turnaround.*
6. **A waiver from Section 7.1.5(e) requiring a landscaped cul-de-sac island.**

- a. *The Applicant requests a waiver from this requirement due to access, plowing and maintenance concerns.*
7. A waiver from Section 7.1.11 requiring the installation of street lighting.
    - a. *The Applicant requests a waiver of this requirement due to the opined limited extension, wetland implications and that typical house and driveway lighting is to be provided.*
  8. A waiver from Section 7.1.7.a requiring vertical granite curbing.
    - a. *The Applicant requests a waiver of this requirement as it is a minor extension of a street without curbing.*
  9. A waiver from Section 7.2 requiring sidewalks along both sides of the roadway.
    - a. *The Applicant requests a waiver from this requirement due to no existing sidewalks along Walnut Street.*
  10. A waiver from Section 7.6 requiring the installation of street trees.
    - a. *The Applicant requests a waiver from this requirement due to the proposed extension of Annette Lane by 30-feet and the fact that the rest of the way shall remain on paper.*

**CONDITIONS:**

**General:**

1. **Definitive Subdivision:** Should the Applicant wish to proceed with this project, Definitive Subdivision Plans shall be submitted to the Town within 7 months of the preliminary application filed on June 26, 2023, in conformance with Chapter 41A Section 81Q of the Subdivision Control Law.
2. **Drainage Design:** No drainage design is approved herein. The Definitive Plans shall include any LID or conventional stormwater management features proposed on-site, along with relevant calculations and documentation as may be required by the Town Engineer. Requirements within Section 7.4.4.3 of the Subdivision Rules and Regulations shall be met; if a waiver from such requirements is to be sought, relevant reasoning shall be provided. Infrastructure shall be designed to meet Standard 1 through 6, for New Development, of the Massachusetts Stormwater Management Standards; as well as any post-construction design requirements. An Operation and Maintenance Plan associated with the infrastructure is to be submitted.
  - a. **Stormwater Permit Application:** The Applicant shall file a Stormwater Permit Application with the Community Development Director, Conservation Administrator, and Town Engineer. Requirements of the Stormwater Regulations shall be met and approved by the Conservation Commission.
3. **Test Boring Logs:** Test Boring Logs shall be provided to the Town Engineer showing the results of all test borings performed as required in Section 6.1.1.d.5 of the Reading Subdivision Rules and Regulations.
4. **Trees/Landscaping/Screening:**

- a. A future Definitive Plan Set shall specify locations and identifications of trees 6-inch caliper or larger and of significant stands or groups of trees, together with indications of trees and groups of trees proposed to be saved or preserved as required per Section 6.1.1.b.13 of the Subdivision Rules and Regulations. If a waiver from such requirement is to be sought, relevant reasoning shall be provided.
  - b. The Applicant shall provide replacement trees on each lot at the ratio of at least one such tree for each 2,000 square-feet of open area on such lot as required per Section 7.6.2.2 of the Subdivision Rules and Regulations. If a waiver from such requirement is to be sought, relevant reasoning shall be provided.
  - c. All trees proposed to be removed from within the 100' wetland buffer shall be approved by the Conservation Commission. Any proposed Street Trees will not count towards the Conservation replacement requirement.
5. **Utilities:** The Applicant shall work with the DPW and RMLD to ensure compliance with all utility extension requirements. Utilities for the new homes are required to be underground.
  6. **Other Permits:** The Applicant is responsible for obtaining all other required Federal, State and Local permits, including but not limited to: Definitive Subdivision Plan Approval from the CPDC, a NPDES Permit; Stormwater Permit, utility permits for sewer, water, electric, etc.; curb cut, driveway, MassDOT and Jackie's Law excavation permits; Board of Health approvals; and an Order of Conditions from the Conservation Commission.
  7. **ORAD and NOI:** As appropriate prior to submitting a Definitive Subdivision Plan, the Applicant shall submit an Order of Resource Area Delineation (ORAD) and Notice of Intent (NOI) application with the Conservation Commission.
  8. **Health Division:** As appropriate, prior to submitting a Definitive Subdivision Plan, the Applicant shall ensure compliance with applicable requirements of the Health Department.
  9. **Snow Storage:** The Applicant shall coordinate with the Conservation Commission, Engineering Department, and DPW Department, to determine the most appropriate location on-site for snow storage.
  10. **Electric Utility:** The electric utility plan shall be submitted and approved by the Reading Municipal Light Department (RMLD). Locations of light poles, transformers, etc. shall be added to the plans and approved by RMLD.
  11. **Property Maintenance:** The Applicant shall maintain the property in a neat and orderly fashion while the development is pending, and during construction.

*Signed as to the accuracy of the vote as reflected in the minutes:*

---

Andrew MacNichol, Community Development Director

Date

*Cc: Applicant, Town Clerk, CPDC, Development Review Team, Building Inspector, planning file*



## Town of Reading

16 Lowell Street, Reading, MA 01867

### Community Planning & Development Commission

Andrew MacNichol *Community Development Director*

Direct: 781-942-6670

[amacnichol@ci.reading.ma.us](mailto:amacnichol@ci.reading.ma.us)

[readingma.gov/community-planning-and-development-commission](http://readingma.gov/community-planning-and-development-commission)

July 10, 2023

# Major Modification to a Definitive Subdivision Plan DECISION of APPROVAL

*Land of: 4 Cold Spring Road*

**Proposed Street Name: Grandview Road Extension**

*To the Town Clerk:*

*This is to certify, that at a public hearing of the Reading Community Planning and Development Commission (CPDC), which was opened on May 15, 2023, and closed on XXX, 2023, by a motion duly made and seconded, it was voted:*

“We, the CPDC, as requested by Michael Salamone, under the Town of Reading’s Subdivision Rules & Regulations, and MGL Chapter 41 Sections 81K through 81GG, and under the Town of Reading General Bylaw Section 7.9 and CPDC Stormwater Management and Erosion Control Regulations, to consider the Major Modification to the previously approved 4-Lot Definitive Subdivision Plan for property located at 4 Cold Spring Road (Assessors Map 27, Lot 404), as shown on the plans prepared by Fodera Engineering dated April 20, 2023, and last revised June 20, 2023 in support of an application filed on May 1, 2023, do hereby vote X-0-0 to \_ the said plans, inclusive of the waivers listed herein, subject to the Findings and Conditions below.”

### **MATERIALS:**

The following documents and plans were submitted into the public record:

1. Form B: Application for a Definitive Subdivision Plan, filed with the Town Clerk 5/1/2023.
2. Form G: Designer’s Certificate, dated 4/3/2023.
3. Modification Summary memo from Fodera Engineering, dated 3/10/2023.
4. Certified List of Abutters, dated 4/3/2023.
5. Legal Notice, published in Daily Times Chronicle on 4/25/2023 and 5/3/2023.
6. Major Site Plan Modification Plan Set for Grandview Road Extension, for the land located on 4 Cold Spring Road, Reading, MA 01867, prepared for: Michael Salamone, prepared by: Fodera Engineering, dated 4/20/2023, and revised 6/20/23, including the following:
  - a. Sheet C-0: Cover Sheet, dated 4/20/2023
  - b. Sheet SV-1: Existing Conditions Plan of Land, prepared by PFS Land Surveying Inc., dated 7/8/2020;

- c. Sheet C-1: Plan of Land, dated 4/20/2023, revised 6/20/23
  - d. Sheet C-2: Site and Tree Preservation, dated 4/20/2023, revised 6/20/23
  - e. Sheet C-3: Erosion and Sediment Control Plan, dated 4/20/2023, revised 6/20/23
  - f. Sheet C-4: Grading and Drainage Plan, dated 4/20/2023, revised 6/20/23
  - g. Sheet C-5: Utility and Roadway Profile Plan, dated 4/20/2023, revised 6/20/23
  - h. Sheet C-6: Details Sheet 1, dated 4/20/2023, revised 6/20/23
  - i. Sheet C-7: Details Sheet 2, dated 4/20/2023, revised 6/20/23
7. Stormwater Management Report, 4-Lot Residential Subdivision, Grandview Road Extension, prepared by Fodera Engineering, dated 3/10/2023
  8. HydroCAD Report, dated 6/20/23
  9. Memo from Town Engineer to Community Development Director, dated 5/3/23
  10. Memo from Conservation Administrator to Community Development Director, dated 5/10/23
  11. Memo from Fodera Engineering to Senior Planner, dated 6/20/23
  12. Memo from Town Engineer to Community Development Director, dated 7/6/23
  13. Draft Decision, dated 5/15/2023, revised 7/10/23
  14. Stormwater Permit Application, received 6/20/23

### **FINDINGS:**

1. **Original Approval:** On February 8, 2021 the CPDC approved a Definitive Subdivision Plan for a 4-lot residential subdivision on the land of 4 Cold Spring Road. The existing single-family dwelling was to be retained within a new lot boundary and a net of 3 new house lots and homes created.
2. **Proposal:** Based on changes made in conjunction with the existing occupant the Applicant is proposing the following modifications to their previously approved plan:
  - a. **Lot Lines:** The lot lines between Lots 1 & 2 were redrawn to accommodate the keeping of a shed on Lot 1. This revision to the lot lines results in a revised Lot size for Lot 1 of 22,114sf and Lot 2 of 15,000sf.
  - b. **Lot Usage:** Lot 2, the lot directly abutting the pre-existing home at 4 Cold Spring Road, will not be built at this time, though the lot remains approved as a buildable lot and the impervious surface area of the future home has been included in the stormwater calculations for the subdivision.
  - c. **Building footprints and backyards:** The building footprints for Lots 3 & 4 have each increased from 1,925sf to 2,200sf. Both Lot 3's and Lot 4's "Area of Tree Removal" have increased to provide larger backyards than originally approved. Wooded area to be removed increased from -29,734sf to -34,287sf; total new grass space to be included has increased from 8,050sf to 13,423sf.
  - d. **Grading and Drainage:** The roadway grading was regraded to create a low point at the end of the cul-de-sac. The grading of the road has dropped approximately 2-feet from the original approval. Roadway catch basins have been reduced from two to a single double catch basin at the low point. Stormwater flow from the right of way is directed to the low point through vertical granite curbing previously approved. The catch basin will gravity convey runoff to a newly proposed open infiltration basin through an added sediment forebay.

The roadway lowering allows for the use of a stormwater detention pond/infiltration basin instead of the previously approved stormwater subsurface infiltration system. The grading to the open basin is located entirely within Lot 3 and is setback 10.4-feet

from the eastern property line and X-feet from the dwelling on Lot 3. The basin is an open basin pond design and is sloped no steeper than 4H:1V, with a maximum depth of 4-feet. The detention pond's overflow weir is located on the northeast portion of the basin, directing any possible overflow to the northern low point of the site on Lot 2. Stormwater runoff calculations have been revised and updated in conjunction with the above listed changes.

Roof drainage from the home on Lot 4 will direct directly into the drain manhole and will not daylight.

Previously approved Lot 2 impervious driveway area is included in the stormwater calculations. However, if Lot 2 is developed in the future, roof drainage will require a separate dry well system and would not be directed to the detention pond.

- e. **Private easements:** The proposed drainage easement has also been revised accordingly with the new proposed detention/infiltration basin.
  - f. **Trees/Landscaping/Screening:** By increasing the size of Lot 3 and 4's backyard area the area of tree preservation dropped from 24,282sf to 19,600sf and the estimated number of trees preserved dropped from 353 to 70.
  - g. **Retaining Wall:** A retaining wall has been added to the southern portion of the site. It will be two tiered 3' high walls and will not require disturbing the abutting property.
3. **Stormwater Permit Applicability:** Any activity that results in disturbance of one (1) or more acres of land and any land-disturbing activity that is part of a Common Plan of Development or Sale that will ultimately result in the disturbance of one (1) or more acres of land, shall be subject to the requirements of the Stormwater Management and Erosion Control Bylaw and Regulations. The project proposes to disturb and develop over one acre of land area.
  4. **Conservation:** The proposed changes to the previously approved grading and stormwater infiltration design will require review and approval from the Conservation Commission.
  5. **Board of Health:** In accordance with M.G.L. Ch. 41 Section 81U, a copy of the Form B and plans were submitted to the Board of Health. The Health Agent indicated that the proposed modifications do not warrant any additional requirements or actions from the Health Department.

### **WAIVERS:**

**The Applicant had previously requested, and the Commission had approved the following waivers from the Town of Reading Subdivision Regulations:**

1. A waiver from Section 6.1.1.d.3 requiring the submittal of a full traffic study.

*The development results in three (3) newly created single-family dwellings that would be located on a dead-end street. The Applicant feels that the additional vehicular demand can be determined to have an insignificant impact to the surrounding neighborhood.*

2. A waiver from Section 6.1.1.d.4 requiring the submission of an Environmental Impact Report.

*A protected resource area on-site is found in the buffer zone of an inland vegetated wetland. The Applicant states that minor site grading will be performed no closer than ~75' from the wetland area and will be performed in accordance with local and state*



*regulations. Stormwater control will be properly mitigated on site. There are no Historical properties within 500' of the site and the Applicant feels it can be determined that the project will have an insignificant impact on the protected environment.*

3. A waiver from Section 7.1.1(a) requiring the layout width of a right-of-way to be a minimum of 60'. A waiver has been requested to **reduce the right-of-way layout from 60' to 40'**.

*The project is proposing to develop the existing unimproved way known as Grandview Avenue that has a width of 40'. The right-of-way will remain at 40' but the Applicant is proposing a cul-de-sac that satisfies the subdivision regulation requirements.*

4. A waiver from Section 7.1.2(a) requiring centerlines of opposing streets to be spaced a minimum of 150' apart. **A waiver has been requested to reduce the minimum spacing of 150' to 130'**.

*The Applicant states that Ridge Road is located 130' east, however, the existing ways have been in existence prior to the Subdivision Regulations.*

5. A waiver from Section 7.1.3(a) requiring a minimum of a 30' wide paved way. A waiver has been requested to **reduce the minimum width requirement of 30' to 25'**.

*The Applicant states the 25' roadway width would accommodate the existing 40' right-of-way best by allowing the inclusion of a one-sided 5' sidewalk and 5' wide vegetated strip. The remaining 5' within the right-of-way will be on the west side of the proposed roadway and be graded out onto the Town-owned land.*

6. A waiver from Section 7.1.3(b) requiring dimensions of the proposed roadway, curbing, tree lawns, and sidewalks be conforming to the cross section shown in Figure 1 of the Subdivision Regulations has been requested.

*Figure 1 of the Subdivision Regulations displays a 60' wide right-of-way with two 5' sidewalks, two 10' wide vegetated strips and a 30' wide paved roadway. The Applicant states conforming to Figure 1 is unfeasible due to the proposed 40' right-way-way width.*

7. A waiver from Section 7.1.3(e) requiring side slopes, outside of the exterior street lines, be a maximum allowable slope of one foot horizontal to one foot vertical (1:1) has been requested.

*The Applicant proposes to grade outside of right-of-way limits and onto Town-owned land. The proximity of the proposed road and grading plan prove that it would require a retaining wall to avoid this waiver request and the Applicant feels that grading into the Town property is more practical and beneficial.*

8. A waiver from Section 7.1.4(b) requiring that curb lines at all intersections provide a radius of not less than 30'. A waiver has been requested to **provide a 24' radius curb line at the northeastern corner of the proposed roadway intersection and to provide a 15' radius curb line at the western intersecting side.**

*The Applicant states that the existing intersection at Cold Spring Road and the proposed road is limited in radial width due to the corner property boundary of 4 Cold Spring Road. The Applicant feels the 15' radius on the western intersecting side will be satisfactory due to the absence of a western roadway intersection.*

9. A waiver from Section 7.1.5(e) requiring a landscape island to be installed within the cul-de-sac has been requested.

*The Applicant states that a fully paved cul-de-sac turnaround will be provided for emergency access and feels that a landscaped island presents maintenance and plowing concerns.*

10. A waiver from Section 7.2(a) requiring sidewalks to be constructed on both sides of the proposed street. The Applicant is proposing **a sidewalk on one side of the proposed street.**

*The Applicant states that due to the proposed 40' right-of-way sidewalks on both sides are not practical and that a sidewalk will be provided on one side of the proposed road.*

11. A waiver from Section 7.5.4 requiring a 20' slope easement to be provided beyond the road layout for appropriate grading behind the sidewalk. A waiver has been requested to **increase the easement from 20' to 30' on the west side of the road and into the Town owned land abutting the project site.**

*The Applicant states that this waiver would benefit the proposed grading discussed in Waiver #7 above.*

## **CONDITIONS:**

### **General:**

- 1) **Plan Modification:** Upon approval of a Major Modification, the Applicant shall submit one (1) paper copy and one (1) electronic copy, in a format acceptable to the Building Inspector, of the modified plan, as well as a letter issued by a registered professional engineer, registered architect or registered landscape architect certifying, under pains and penalties of perjury, that the modified plan is consistent in all aspects with the approved modification and that all conditions of approval have been satisfied.
- 2) **February 8, 2021 Approval:** All conditions listed in the February 8, 2021 approval remain in full force and effect to the extent that they are not rendered obsolete by the Major Modification herein.
- 3) **Conservation:** The Applicant shall coordinate with the Conservation Administrator to comply with the requests and conditions imposed of/by the Conservation Commission.

### **Stormwater Permit Conditions:**

- 1) The Applicant shall notify the Community Development Director and Town Engineer before significant site milestones, such as installation of erosion and sediment control measures or completion of site clearing.

- 2) The Applicant shall conduct and document periodic inspections of all control measures (before, during and/or after construction) and submit reports to the Community Development Director and Town Engineer.
- 3) The Applicant shall post, before the start of land disturbance activity, a cash bond or other surety to secure the performance of the Permittee's obligations under the Stormwater Permit.
- 4) The Applicant shall record notice of the Operation & Maintenance Plan with the Registry of Deeds (or the Land Court for registered land).
- 5) The Applicant shall establish a dedicated source of funding for long-term operation and maintenance of stormwater control measures, if not conducted by the Town.
- 6) The Applicant shall submit, to the Community Development Director and Town Engineer, an annual certification documenting the work that has been done over the last 12 months to properly operate and maintain the stormwater control measures.
- 7) The Applicant shall notify the CPDC in writing of any change or alteration of a land-disturbing activity authorized in a Stormwater Permit before the change or alteration occurs. If the proposed change or alteration is minor, the Community Development Director, after coordinating with the Town Engineer, may authorize such change or alteration in writing with a copy to the CPDC. Otherwise, the Community Development Director shall forward the notification of change or alteration to the CPDC. If the CPDC determines that the change or alteration is significant, it may require the Permittee to apply for an amendment to the Stormwater Permit.
- 8) The Approval of the Stormwater Permit shall lapse two (2) years after the date of its issuance if construction pursuant thereto has not begun; provided however, that the CPDC may grant an extension of the two (2) year period, for a maximum of one (1) year, upon a finding of good cause, including the need to obtain other local, state, and federal permits duly applied for, at the written request of the applicant, if submitted to the CPDC at least thirty (30) days prior to the expiration of the two (2) year period.
- 9) The CPDC may, upon application by the Permittee, amend a Stormwater Permit. Any such amendment shall conform to the requirements of the Stormwater Management and Erosion Control Bylaw and Regulations.
- 10) Within 60 days of the completion of construction of the project, the Permittee shall submit to the Community Development Director and Town Engineer a record plan detailing the actual stormwater management system as installed. The as-built plan must depict all on-site controls, both structural and non-structural, designed to manage the stormwater associated with the completed site. Such plan shall be provided both in hard copy and as an electronic file. Upon review of the as-built plan, the Community Development Director and Town Engineer may approve it or may direct the Permittee to take any actions necessary to correct the plan or to comply with any outstanding requirements of the Stormwater Permit.

**Prior to Plan Endorsement:**

- 1) **Plan Revisions:** The Applicant shall revise the Site Plan pursuant to any conditions imposed herein and submit 2 full-size (24x36) copies of the revised plans to the Community Development Director for review and approval prior to the issuance of a Building Permit. Revisions include but are not limited to:
  - a.

- 2) **Mylars:** The Applicant shall submit two (2) complete sets of mylar plans, and an electronic version, to the Community Development Director for endorsement by the CPDC.
- 3) **Electric Utility and Easement:** The proposed changes to the electric utility plan shall be approved by the Reading Municipal Light Department (RMLD). Locations of light poles, transformers, etc. shall be added to the plans and approved by RMLD.

**Prior to the Commencement of Site Work, Road Work or Utility Work:**

- 1) **Other Permits:** The Owner/Applicant is responsible for meeting all other requirements and obtaining all other permits as needed including but not limited to: Order of Conditions from the Conservation Commission, utility connections, street opening, and Jackie's Law excavation permits from the Engineering Department (prior to excavation).
- 2) **Recorded Plans:** The Applicant shall provide electronic copies of the recorded plans and all other recorded documents to the Community Development Director.
- 3) **Engineering Comments:** The Applicant shall coordinate with the Town Engineer to resolve any necessary outstanding comments listed in the memo dated 5/3/23.

**Prior to the Issuance of Occupancy for Any Lot:**

- 1) **Access Easement:** The Applicant shall provide a copy of the executed and recorded Access and Utility Easement established between Lot Three and Lot Four.
- 2) **Closing Documents for Homeowners:** Additional reference to the Stormwater Operation and Management Plan shall include language that no structure, trees, fill and/or blockage of the stormwater detention pond within Lot Three shall be allowed. Additional language as to the maintenance, cleaning and responsibilities to ensure the detention pond works as designed shall be included.

*Signed as to the accuracy of the vote as reflected in the minutes:*

---

Andrew MacNichol, Community Development Director

Date

*Cc: Applicant, Town Clerk, CPDC, Development Review Team, Building Inspector, planning file*